

DENISON HYDRAULICS
Premier Series
piston pumps for open circuits
P09C & P140C
service information

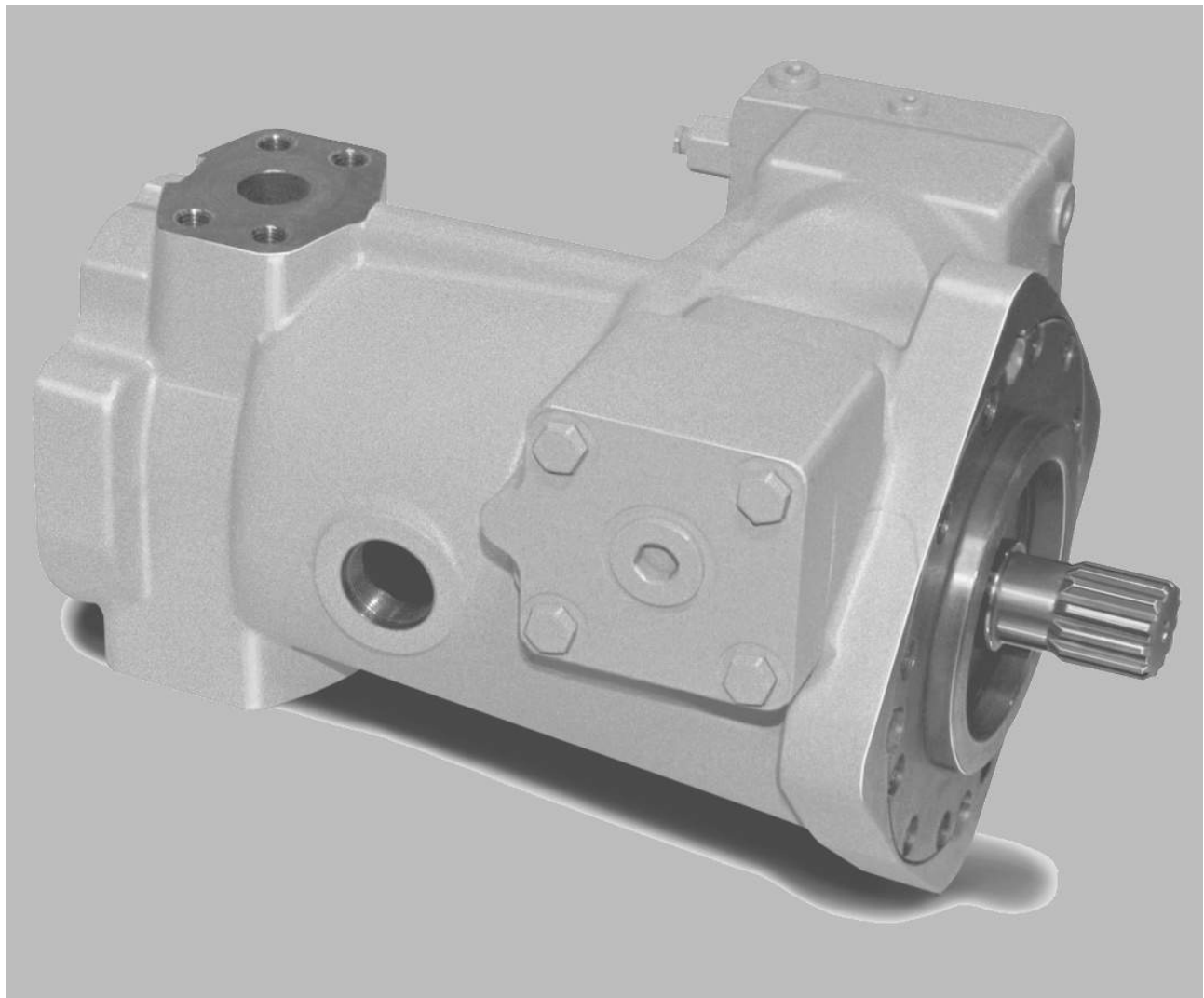

Publ. LT2-00039-2-A replaces LT2-00039-2 & S1-AM0033

Revised 5/03

DENISON Hydraulics

Internet <http://www.denisonhydraulics.com> E-mail: denison@denisonhydraulics.com

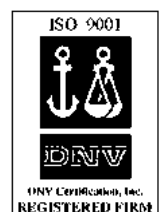

TITLE	PAGE
Port Identification	3
Start up Procedure	7
Trouble shooting charts	8
Disassembly	10
Rework limits	11
Parts list	12
Rear drive adapters	16
Conversion	17
Reassembly	18
Controls	25
Pressure compensator.....	27
Maximum Volume Stop; Handwheel	30
Buck-up cap assembly	31
Torque limiter	32
Load sensing control	36
Load sensing torque limiter	39
Rotary servo	43
Hydraulic stroker	47
Electrohydraulic stroker	50
PQ control	54
Control tubing; Control cap	58
Compensator override control	59
Torque limiter override control	61
Testing	64
Rotary servo test	64
Compensator test.....	66
Load sensing test.....	67
Hydraulic stroker test	68
Electrohydraulic stroker test.....	69
Torque limiter and torque limiter override test	70
Load sensing torque limiter test.....	72
PQ control test	74
Pump test	75
Tools	76
Characteristics.....	77
Ordering code	79

Seal kit.....	P09	S22-15084
.....	P140	S22-15085
.....	P09 with "X" control	S22-16479
.....	P140 with "X" control	S22-16480

The shaft seal and all "O" rings necessary for total seal replacement may be obtained by ordering Seal Kit . These seals are suitable for petroleum base fluids. For fire resistant fluids contact **DENISON HYDRAULICS**, Inc. or their authorized distributors to obtain the appropriate seal kit number.

The product information, specifications, and descriptions contained in this publication have been compiled for the use and convenience of our customers from information furnished by the manufacturer; and we can not, and do not, accept any responsibility for the accuracy or correctness of any description, calculation, specification, or information contained herein. No such description, calculation, specification, or information regarding the products being sold has been made part of the basis of the bargain, nor has same created or amounted to an express warranty that the products would conform thereto. **We are selling the goods and merchandise illustrated and described on this publication on an "as is" basis, and disclaim any implied warranty, including any warranty of merchantability or warranty of fitness for any particular purpose whatsoever, with respect to the goods and merchandise sold.** All manufacturer warranties shall be passed on to our customers, but we shall not be responsible for special, indirect, incidental, or consequential damages resulting from the use of any of the products or information contained or described on this publication. Further, we reserve the right to revise or otherwise make product improvements at any time without notification.

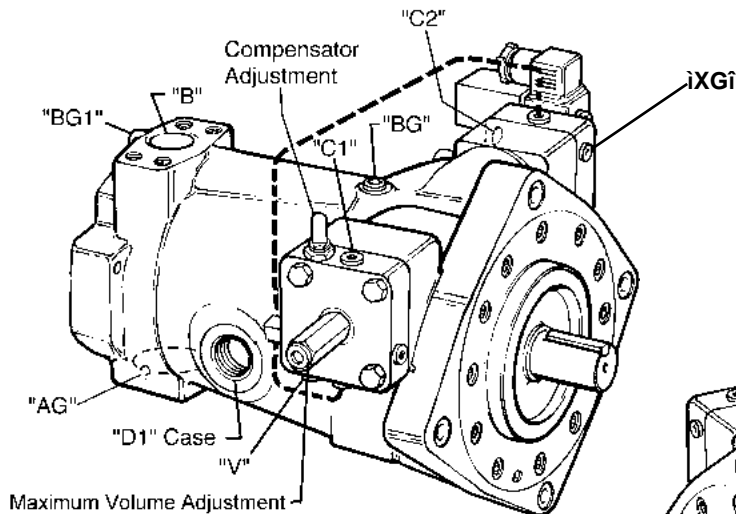

Electric-Hydraulic Stroker Shown with Compensator Override

CCW ROTATION SHOWN

TIGHTENING TORQUE FOR HYDRAULIC PLUGS

PORT SIZE	ft-lbs	Nm
SAE-4	11	15
SAE-6	18	24
SAE-8	46	62
SAE-10	75	102
SAE-14	130	175
SAE-20	225	305
1/8 BSPP	7	9
1/4 BSPP	18	24
3/8 BSPP	18	24
1/2 BSPP	93	126
1-1/2 BSPP	288	390

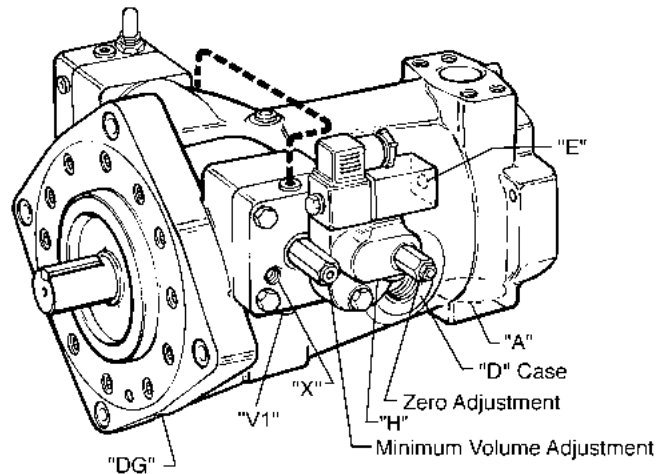

FLUID CONNECTIONS

DESCRIPTION	P09	P140
PORT AINLET	3 SAE CODE 61	3 SAE CODE 61
	5/8-11 SCREWS	M16-2 SCREWS
PORT BSYSTEM.....	1-1/2 SAE CODE 62	1-1/2 SAE CODE 62
	5/8-11 SCREWS	M16-2 SCREWS
PORT C1OFF-STROKE CYLINDER GAGE	SAE-4	1/4 BSPP
PORT C2ON-STROKE CYLINDER GAGE	SAE-4	1/4 BSPP
PORT DCASE DRAIN	SAE-20	1-1/2 BSPP
PORT D1CASE DRAIN	SAE-20	1-1/2 BSPP
PORT DGDRAIN GAGE, AIR BLEED PORT	SAE-4	1/8 BSPP
PORT AGINLET GAGE.....	SAE-4	1/4 BSPP
PORT BGSYSTEM GAGE.....	SAE-4	1/4 BSPP
PORT BG1 ..ALTERNATE SYSTEM GAGE	SAE-6	1/4 BSPP
PORT EELECTROHYDRAULIC STROKER SERVO SUPPLY	SAE4	1/4 BSPP
PORT HHYDRAULIC STROKER SIGNAL	SAE-4	1/4 BSPP
PORT LSLOAD SENSING LINE (SEE PAGE 4)	SAE-4	1/4 BSPP
PORT VCOMPENSATOR, TORQUE LIMITER, LOAD SENSING VENT	SAE-8	3/8 BSPP
PORT V1SERVO VENT	SAE-4	1/4 BSPP
PORT XSERVO SUPPLY	SAE-8	3/8 BSPP
PORT XGSERVO GAGE	SAE-10	1/2 BSPP

PRIMARY CONTROLS

CLOCKWISE ROTATION

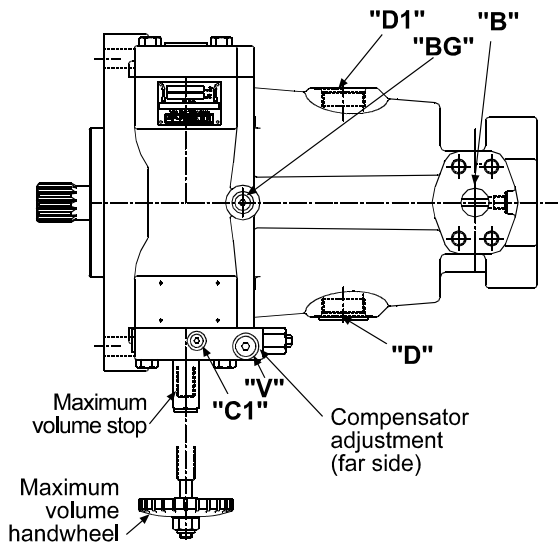

"C1", "C2" COMPENSATOR

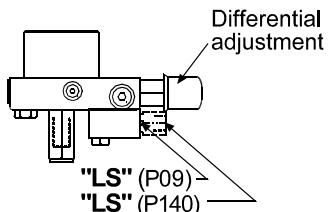

"L1", "L2" LOAD SENSING

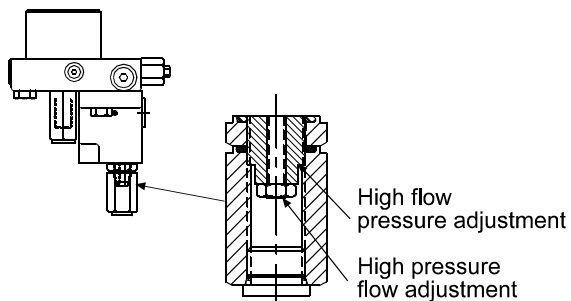

"J1/K1", "J2/K2" TORQUE LIMITER

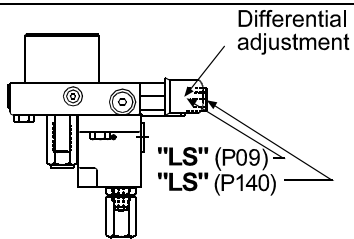

"V1/W1", "V2/W2" LOAD SENSING TORQUE LIMITER

COUNTERCLOCKWISE ROTATION

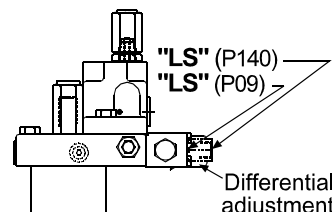

"V1/W1", "V2/W2" LOAD SENSING TORQUE LIMITER

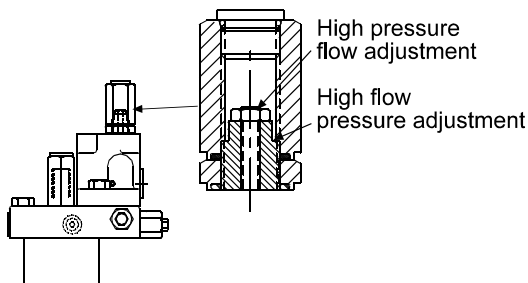

"J1/K1", "J2/K2" TORQUE LIMITER

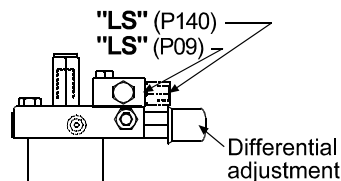

"L1", "L2" LOAD SENSING

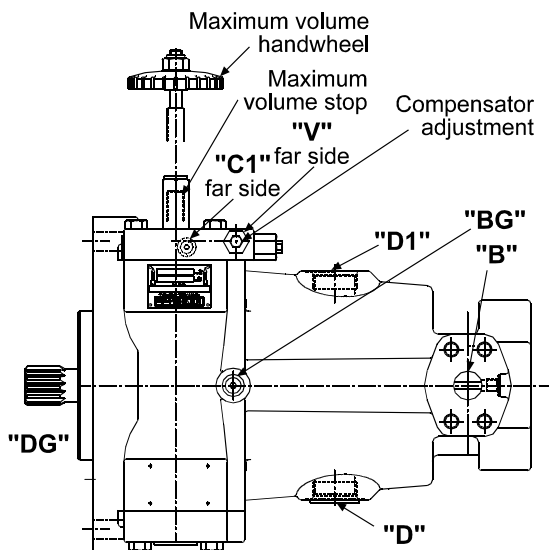

"C1", "C2" COMPENSATOR

**CLOCKWISE
ROTATION**

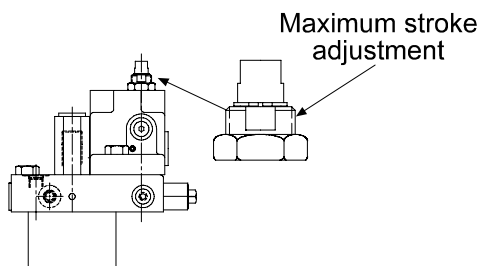

"R" ROTARY SERVO

**COUNTERCLOCKWISE
ROTATION**

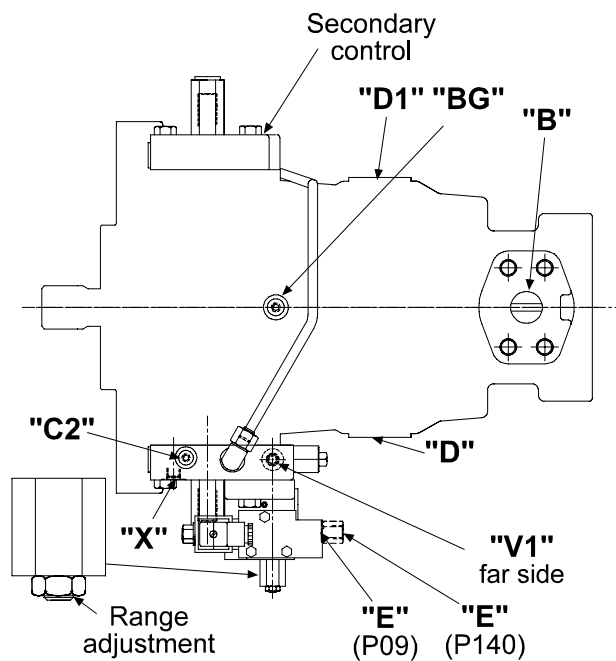

"E" ELECTROHYDRAULIC STROKER

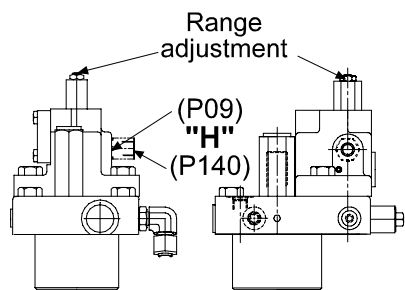

"H" HYDRAULIC STROKER

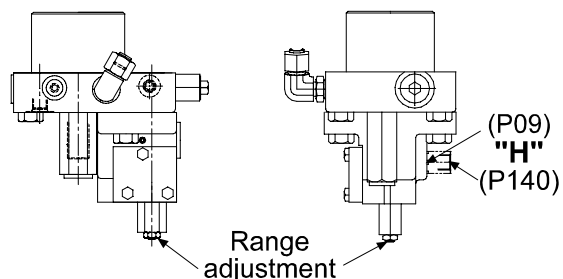

"H" HYDRAULIC STROKER

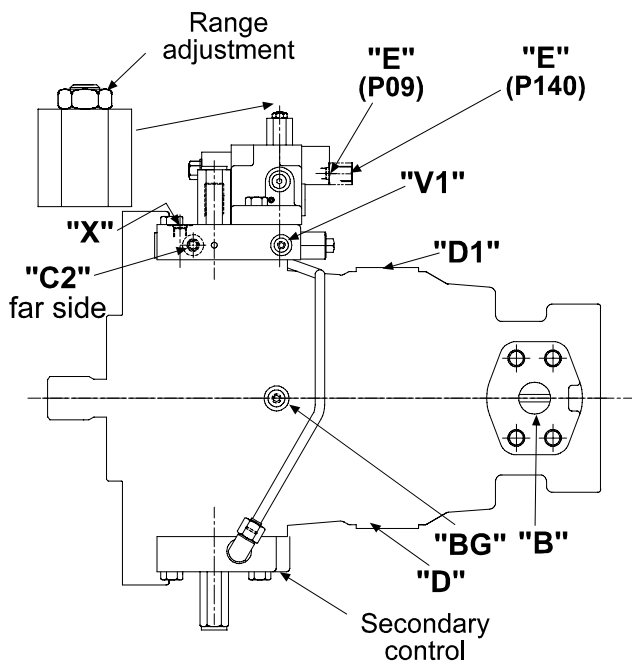

"E" ELECTROHYDRAULIC STROKER

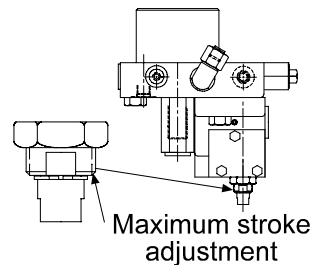

"R" ROTARY SERVO

SECONDARY CONTROLS

CLOCKWISE ROTATION

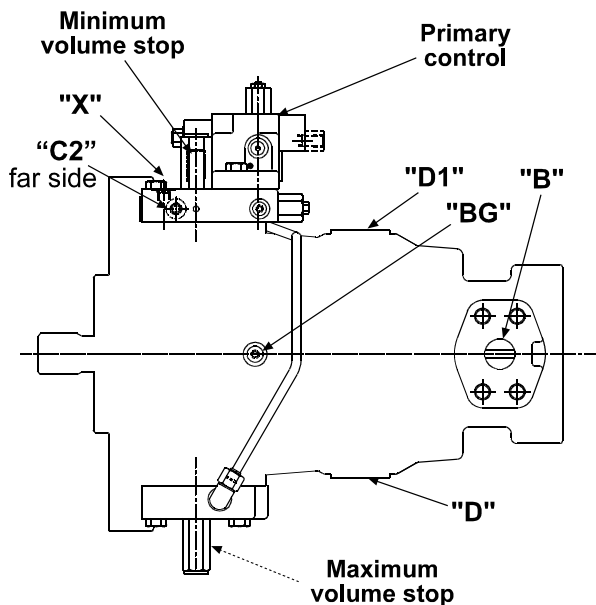

"*10"
CONTROL CAP WITH
MAXIMUM VOLUME STOP

COUNTERCLOCKWISE ROTATION

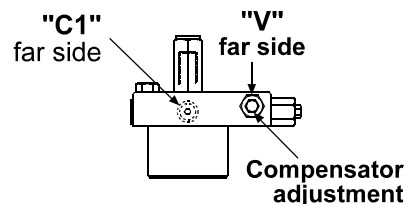

"*1P"
COMPENSATOR OVERRIDE WITH
MAXIMUM VOLUME STOP

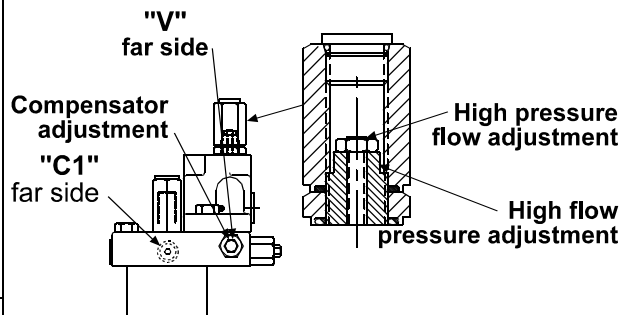

"*1J", "*1K"
TORQUE LIMITER OVERRIDE WITH
MAXIMUM VOLUME STOP

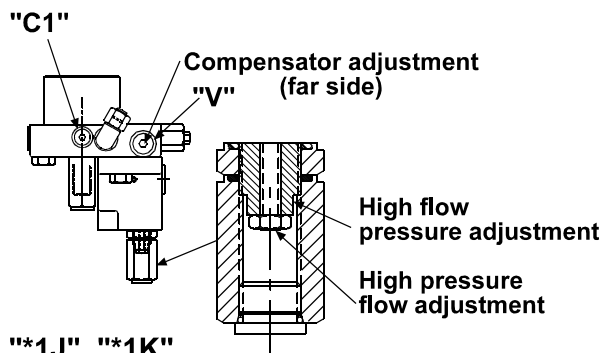

"*1J", "*1K"
TORQUE LIMITER OVERRIDE WITH
MAXIMUM VOLUME STOP

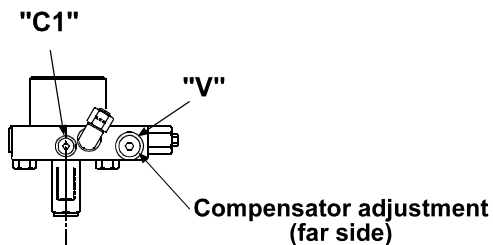

"*1P"
COMPENSATOR OVERRIDE WITH
MAXIMUM VOLUME STOP

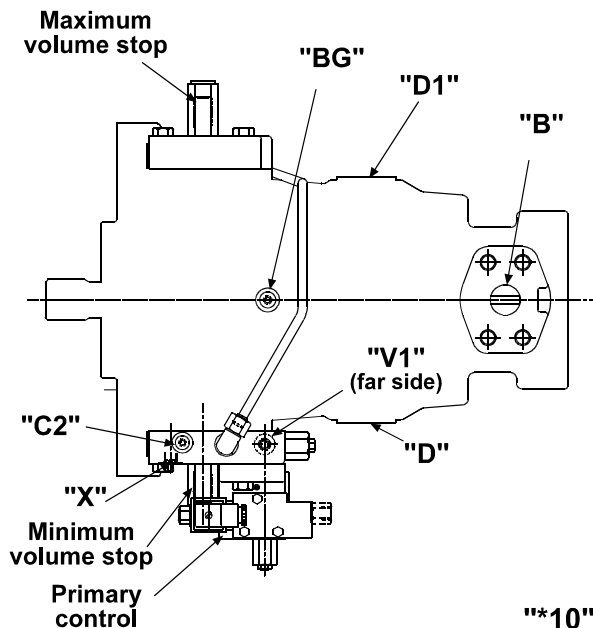

"*10"
CONTROL CAP WITH
MAXIMUM VOLUME STOP

START UP PROCEDURE FOR NEW INSTALLATION

- Read and understand the instruction manual. Identify components and their function.
- Visually inspect components and lines for possible damage.
- Check reservoir for cleanliness. Drain and clean as required
- Check fluid level and fill as required with filtered fluid at least as clean as that recommended. Fill pump case with clean oil prior to starting. If pump is mounted vertically with shaft up, bleed air from case by removing plug from port "DG" till fluid runs clear.
- Check alignment of drive.
- Check oil cooler and activate it, if included in circuit. Check fluid temperature
- Reduce pressure settings of compensator and relief valve. Make sure accurate pressure readings can be made at appropriate places.
- If solenoids are in system, check for actuation.
- Start pump drive. Observe for correct shaft rotation. Make sure pump fills properly.
- Bleed system of air. Recheck fluid level.
- Cycle unloaded machine at low pressure and observe actuation (at low speed, if possible).
- Increase pressure settings gradually in steps. Check for leaks in all lines, especially in pump inlet lines.
- Make correct pressure adjustments.
- Gradually increase speed. Be alert for trouble as indicated by changes in sounds, system shocks and air in fluid.
- Equipment is operational.

TROUBLESHOOTING

Component problems and circuit problems are often interrelated. An improper circuit may operate with apparent success but will cause failure of a particular component within it. The component failure is the effect, not the cause of the problem. This general guide is offered to help in locating and eliminating the cause of problems by studying their effects.

Effect of Trouble	Possible Cause	Fault Which Needs Remedy
pump noisy	air in system	leak in suction line. low fluid level. turbulent fluid. return lines above fluid level. gas leak from accumulator. excessive pressure drop in the inlet line from a pressurized reservoir. suction line strainer acting as air trap.
	cavitation in rotating group.	fluid too cold, too viscous, or too heavy. shaft speed too high. suction line strainer too small, or strainer too dirty. operating altitude too high. boost pressure too low. inlet flow too small for dynamic conditions.
	misaligned shaft.	faulty installation. distortion in mounting. axial interference. faulty coupling. excessive overhung loads.
	mechanical fault in pump.	piston and shoe looseness or failure. bearing failure. incorrect port plate selection or index. eroded or worn parts in the displacement control.
erosion on barrel ports and port plate.	air in fluid. cavitation.	see noisy pump above. see noisy pump above.
high wear in pump.	excessive loads.	reduce pressure settings. reduce speeds.
	contaminant particles in fluid.	improper filter maintenance. filters too coarse. introduction of dirty fluid to system. reservoir openings. improper reservoir breather. improper line replacement.
	Improper fluid.	fluid too thin or thick for operating temperature range. breakdown of fluid with time/temperature/shearing effects. incorrect additives in new fluid. destruction of additive effectiveness with chemical aging
	improper repair.	incorrect parts, procedures, dimensions, finishes.
	unwanted water in fluid.	condensation. faulty breather/strainer. heat exchanger leakage. faulty clean-up practice. water in makeup fluid.
pressure shocks.	cogging load.	mechanical considerations.
	worn relief valve.	needed repairs.
	worn compensator.	needed repairs.
	slow response in check valves.	replace or relocate.
	excessive decompression energy rates.	improve decompression control.
	excessive line capacitance. (line volume, line stretch, accumulator effects). barrel blow-off.	reduce line size or lengths. eliminate hose. re-check pump holddown, rotating group, drain pressure.
heating of fluid.	excessive pump leakage.	recheck case drain flow and repair as required. fluid too thin. improper assembly, port timing.
	relief valve.	set too low (compared to load or to compensator). instability caused by back pressure, worn parts.
	compensator.	set too high (compared to relief). worn parts.
	pump too large for fluid needs.	select smaller pump displacement.
	heat exchanger.	water turned off, too hot or too little flow. fan clogged or restricted. efficiency reduced by mud or scale deposits. intermittent hydraulic fluid flow.
	reservoir.	too little fluid. improper baffles. insulating air blanket that prevents heat rejection. heat pickup from adjacent equipment..

TROUBLESHOOTING

Effect of Trouble	Possible Cause	Fault Which Needs Remedy
Compensator, Compensator Override		
Low system pressure	Compensator malfunction	Dirt in spool orifice Damaged cone or seat Broken differential spring Improperly adjusted differential spring
Failure to compensate	Differential adjustment	Differential set too high
Sluggish response	Differential adjustment	Differential set too low
Wide pressure fluctuations (hunting)	Excessive line capacitance	Install check valve near pump outlet
Load Sensing Control		
Low system pressure	Compensator malfunction	Dirt in spool orifice Damaged cone or seat Broken differential spring Improperly adjusted differential spring
Failure to compensate	Differential adjustment	Differential set too high
Sluggish response	Differential adjustment Modulating valve	Differential set too low Air in load sensing line
Wide pressure fluctuations (hunting)	Excessive line capacitance Modulating valve	Install check valve near pump outlet Air in load sensing line
Excessive pressure drop across control valve	Differential adjustment	Differential set too high
Poor control of flow	Differential adjustment	Differential set too low
Torque Limiter, Torque Limiter Override		
Torque setting erratic	Torque limiter cap malfunction	Sticking pin
Torque incorrect at high flows	Incorrect torque setting	Outer adjustment screw
Torque incorrect at low flows	Incorrect torque setting	Inner adjustment screw
Too much torque variation	Wrong torque limiter for range	Replace inner/outer springs with correct springs
Low system pressure	Compensator malfunction	Dirt in spool orifice Damaged cone or seat Broken differential spring Improperly adjusted differential spring
Failure to compensate	Differential adjustment	Differential set too high
Sluggish response	Differential adjustment	Differential set too low
Wide pressure fluctuations (hunting)	Excessive line capacitance	Install check valve near pump outlet
Rotary Servo		
Failure to stroke	Differential adjustment	Differential set too low
Goes to full	Differential adjustment	Differential set too high
Sluggish response	Low servo pressure	Check servo pressure
Strokes in steps	Servo cap malfunction	Sticking pin Wear on linkages or input cam surface
Hydraulic Stroker		
Failure to stroke	Differential adjustment	Differential set too low
Goes to full	Differential adjustment	Differential set too high
Strokes in steps	Servo cap malfunction	Wear on linkages, Sticking stroker piston
Electric Stroker		
Failure to stroke	Differential adjustment	Differential set too low
Goes to full	Differential adjustment	Differential set too high
Excessive hysteresis	Electric proportional valve	Change dither on electrical signal
No response	Electric proportional valve	Faulty wiring, Filter screen plugged
Strokes in steps	Servo cap malfunction	Wear on linkages Sticking stroker piston
Instability	Air in control	Bleed air from control Check for air in servo supply

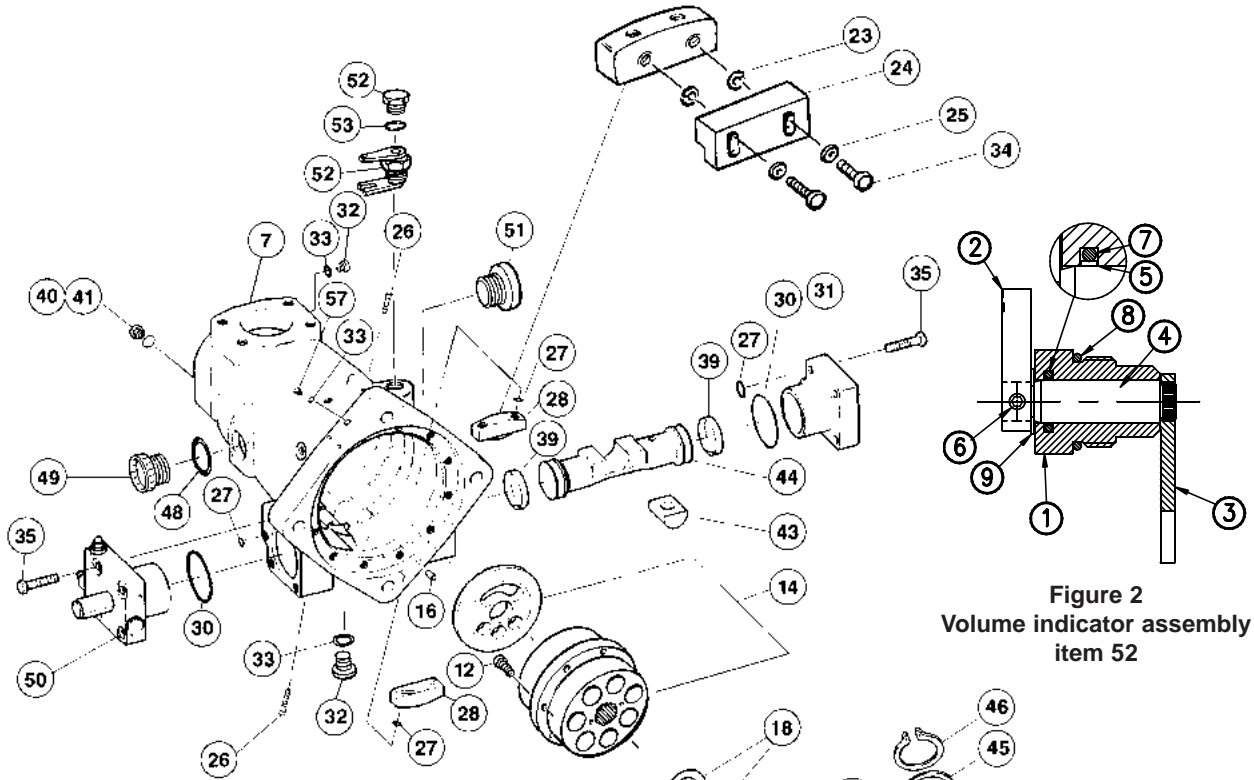

Figure 2
Volume indicator assembly
item 52

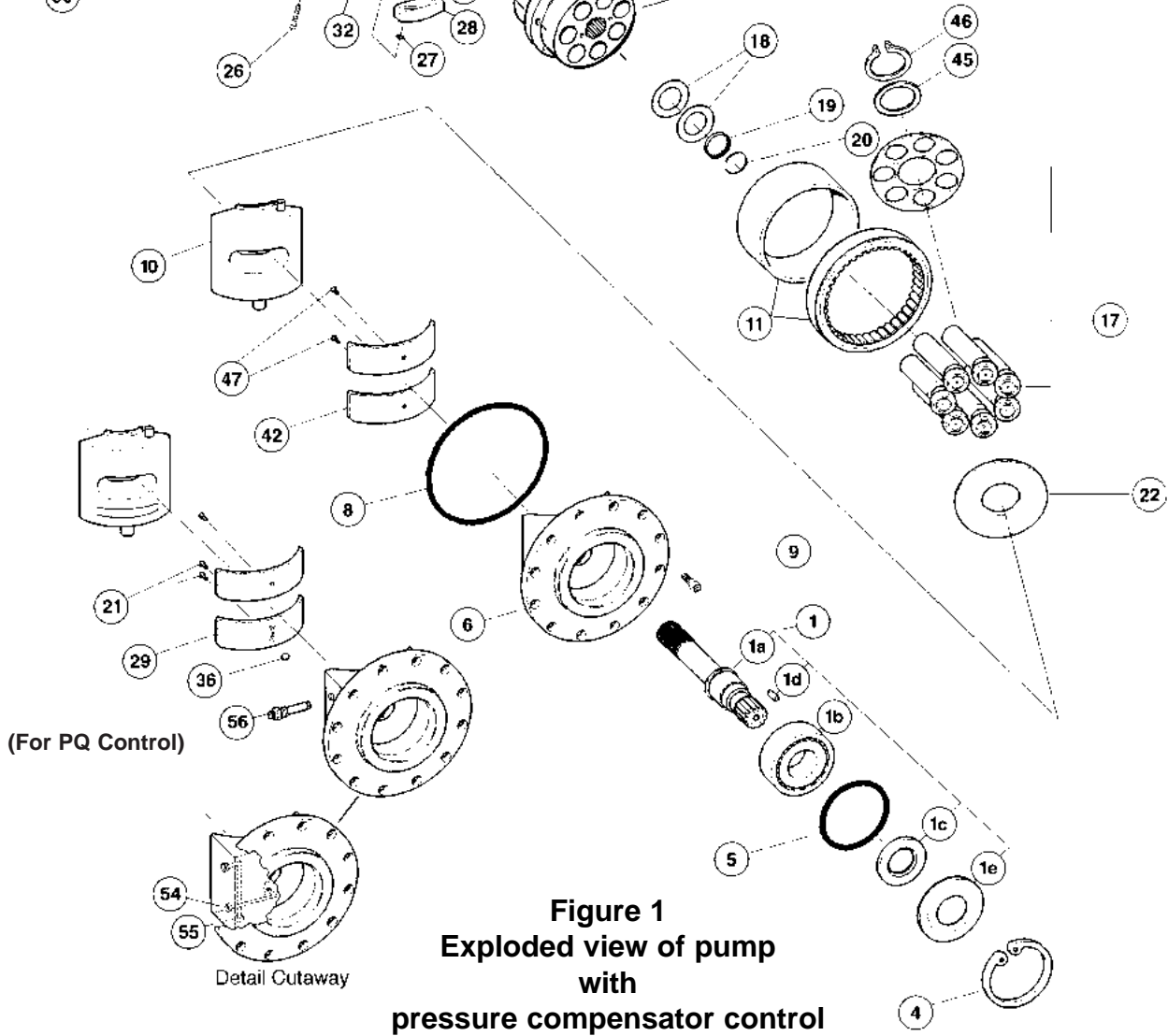

Figure 1
Exploded view of pump
with
pressure compensator control

Disassembly

Disassemble only as far as necessary to replace or repair worn parts.

If the pump has a rear drive, the mounting adapter and coupling must be removed prior to pump disassembly *Refer to figure 3 page 16.*

Clean outside surface of the pump before disassembly. Disassembly area should be clean. A suitable surface should be used capable of supporting the pump weight of 220 pounds, 100 Kg.

Refer to illustration, see figure 1 and 2

1. Remove plug (49) and drain oil from pump. Position pump with shaft up.
2. Wind maximum volume screw ref. see item (50), CW so that piston (44) bottoms out. This positions the cam at approximately zero stroke allowing removal of the drive shaft. *Reference item 1 page 27.*
3. Remove socket head cap screws (9). If disassembling PQ Control version, remove tubing and pass thru fitting (56).
3. Remove cradle assembly (6) from the housing. The 3/8-16 threaded hole in end of the shaft is provided for lifting this assembly.
5. Remove snap ring (4).
6. Remove screws (47) to remove cam bearings (42).
7. Remove shaft, bearing, and seal retainer assembly (1). Support flat face of the rocker cradle and press end of shaft opposite the bearing end.
8. Remove the shaft seal (1c) from the retainer (1e) if necessary.
9. Remove retaining ring (20).
10. Press bearing off shaft if necessary. Press against bearing inner race.
11. If pump contains a volume indicator assembly (52): *Refer to. Figure 2:* Remove indicator pointer (2), retaining ring (9) and pivot nut (1) from pump housing. Remove pivot shaft and fork assembly (3) and (4) through the hole.
12. Remove two screws (34), two washers (25), clearance bearing (24), and two washers (23) from retainer (28).
13. For compensator, torque limiter or load sensing control pumps, wind maximum volume screw CCW until piston (44) bottoms out.
14. Remove control cap (50) and control cap (31). (*Refer to controls section for control disassembly*).
15. Insert two tools (T-2) (see page 77) into housing supporting each end of the control piston. The piston must be moved outward (away from pump center) to remove cam assembly.
16. Lift cam assembly (10) from pump. (Link (43), pistons and shoes and retainer plate(17), wear plate (22), and hold-down (45 and 46) are part of the cam assembly.)
17. Remove slide link (43), retaining ring (46), thrust washer (45), pistons, shoes & retainer assembly (17) and wear plate (22). The pins for the slide link and for the indicator have been pressed into the rocker cam and should not be removed.
18. Remove two screws (34), two screws (26), and two retainers (28).
19. Remove Belleville washers (18) and barrel stop (19).
20. Attach tool (T-1) (pg. 77) to barrel assembly (14). (Two M6 screws are required.) Lift barrel from port plate and housing.
21. The inner race of bearing (11) has a light press fit with barrel. Do not remove the inner race unless bearing needs to be replaced. If replacement is necessary, remove seven socket head cap screws (12). Replace with M6 x 6 1/2 in., 165mm long soc hd cap screws. Rest assembly on the extended screws. Press barrel from inner race. Care must be taken to avoid damage to barrel face.
22. Remove port plate ref. see item (14), and alignment pin (16), from port block.

The barrel bearing outer race (11) should only be removed from housing if worn, damaged or closer inspection is needed. A bearing puller should be used for removal.

REWORK LIMITS OF WEAR PARTS

item	maximum rework from original dimension	minimum dimension after rework
wear plate	.005", 0,127 mm	.184", 4,674 mm
piston shoe face(pocket)	*	.3515", 8,928 mm

*shoe face pocket depth must be .004", 0,10 mm minimum

WEAR PLATE

The wear plate finish must be 10 µin., 0,25 µm min., flat within .0005", 0,0127 mm and parallel to the backside within .001", 0,0254 mm total indicator reading.

PISTON SHOE

The piston shoe wear face finish must be 45 µin., 1,143 µm min, and must be lapped in a set with the retainer plate. All shoe sole thicknesses to be within .001", 0,0254 mm after lapping. The maximum permissible shoe and piston axial looseness is .010", 0,254 mm.

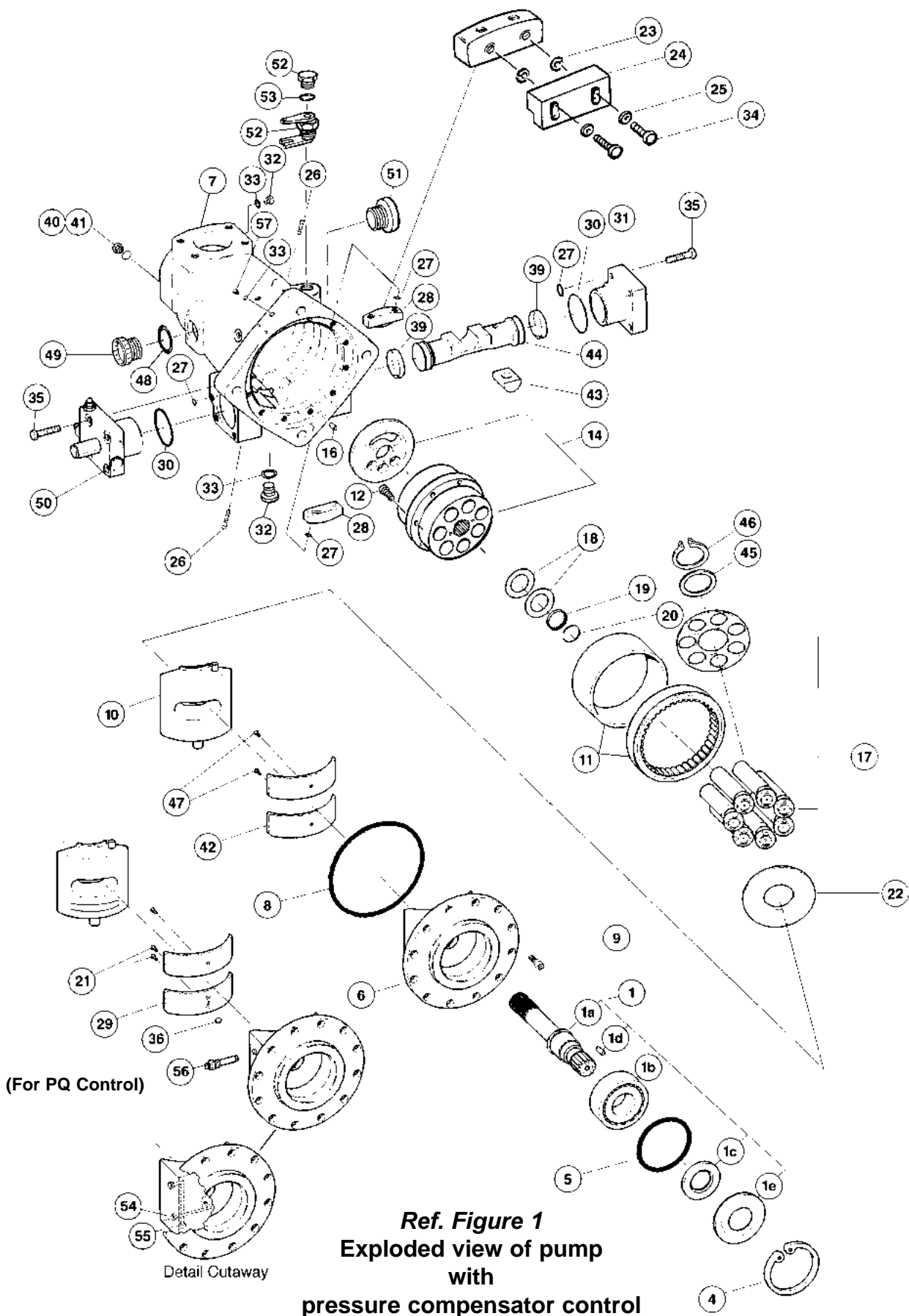

PUMP PARTS LISTS

item	description	part no. P09-SAE	part no. P140-ISO	qty.
1	shaft assembly			1
	keyed, no rear drive	S22-15111	S22-15115	
	a (shaft)	032-91592	032-91594	
	b (bearing)	230-82215	230-82215	
	c (seal)	620-82080	620-82099	
	d (key)	033-71514	211-40000	
	e (seal retainer)	032-91269	032-91269	
	keyed, with rear drive	S22-15112	S22-15116	
	a (shaft)	032-91635	032-91637	
	b (bearing)	230-82215	230-82215	
	c (seal)	620-82080	620-82099	
	d (key)	033-71514	211-40000	
	e (seal retainer)	032-91269	032-91269	
	splined, no rear drive	S22-15113	S22-15117	
	a (shaft)	032-91591	032-91593	
	b (bearing)	230-82215	230-82215	
	c (seal)	620-82080	620-82099	
	e (seal retainer)	032-91269	032-91269	
	splined, with rear drive (standard)	S22-15114	S22-15118	
	a (shaft)	032-91634	032-91636	
	b (bearing)	230-82215	230-82215	
	c (seal)	620-82080	620-82099	
	e (seal retainer)	032-91269	032-91269	
			DIN 50mm	
	keyed, no rear drive		S22-15685	
	a (shaft)		032-92261	
	b (bearing)		230-82215	
	c (seal)		230-82099	
	d (key)		032-92264	
	e (seal retainer)		032-91269	
	keyed, with rear drive		S22-15686	
	a (shaft)		032-92262	
	b (bearing)		230-82215	
	c (seal)		620-82099	
	d (key)		032-92264	
	e (seal retainer)		032-91269	
	splined, no rear drive		S22-15621	
	a (shaft)		032-92260	
	b (bearing)		230-82215	
	c (seal)		620-82099	
	e (seal retainer)		032-91269	
	splined, with rear drive		S22-15622	
	a (shaft)		032-92259	
	b (bearing)		230-82215	
	c (seal)		620-82099	
	e (seal retainer)		032-91269	
4	retainer	356-65130	356-65130	1
5	O-ring, 70 S-1 ARP 158	671-00158	671-00158	1
6	cradle	032-91587	032-91588	1
	cradle, PQ control	032-92815	032-92749	
7	housing, no rear drive	032-91592	032-91583	1
	housing, no rear drive, PQ control	032-92753	032-92752	
	housing, with rear drive	032-91632	032-91633	
	housing, with rear drive, PQ control	032-92896	032-92897	
8	O-ring, 70 S-1 ARP 265	671-00265	671-00265	1
9	screw, SHC	361-11213	361-11213	12
10	cam assembly	S22-15078	S22-15078	1
10	cam assembly, PQ control	S22-16383	S22-16383	1
11	bearing	032-91570	032-91570	1
12	screw, SHC	361-10245	361-10245	7
14	barrel & port plate assembly CW	S22-16147	S22-16147	1
	barrel & port plate assembly CCW	S22-16148	S22-16148	
	barrel & port plate assembly CW, PQ control	S22-16386	S22-16386	
	barrel & port plate assembly CCW, PQ control	S22-16387	S22-16387	
16	dowel pin	324-21610	324-21610	1
17	pistons, shoes,retainer assembly	S22-15119	S22-15119	1
	(17-1) retainer plate (1 req'd)	032-91573	032-91573	
	(17-2) pistons and shoes (7 req'd)	S22-15082	S22-15082	

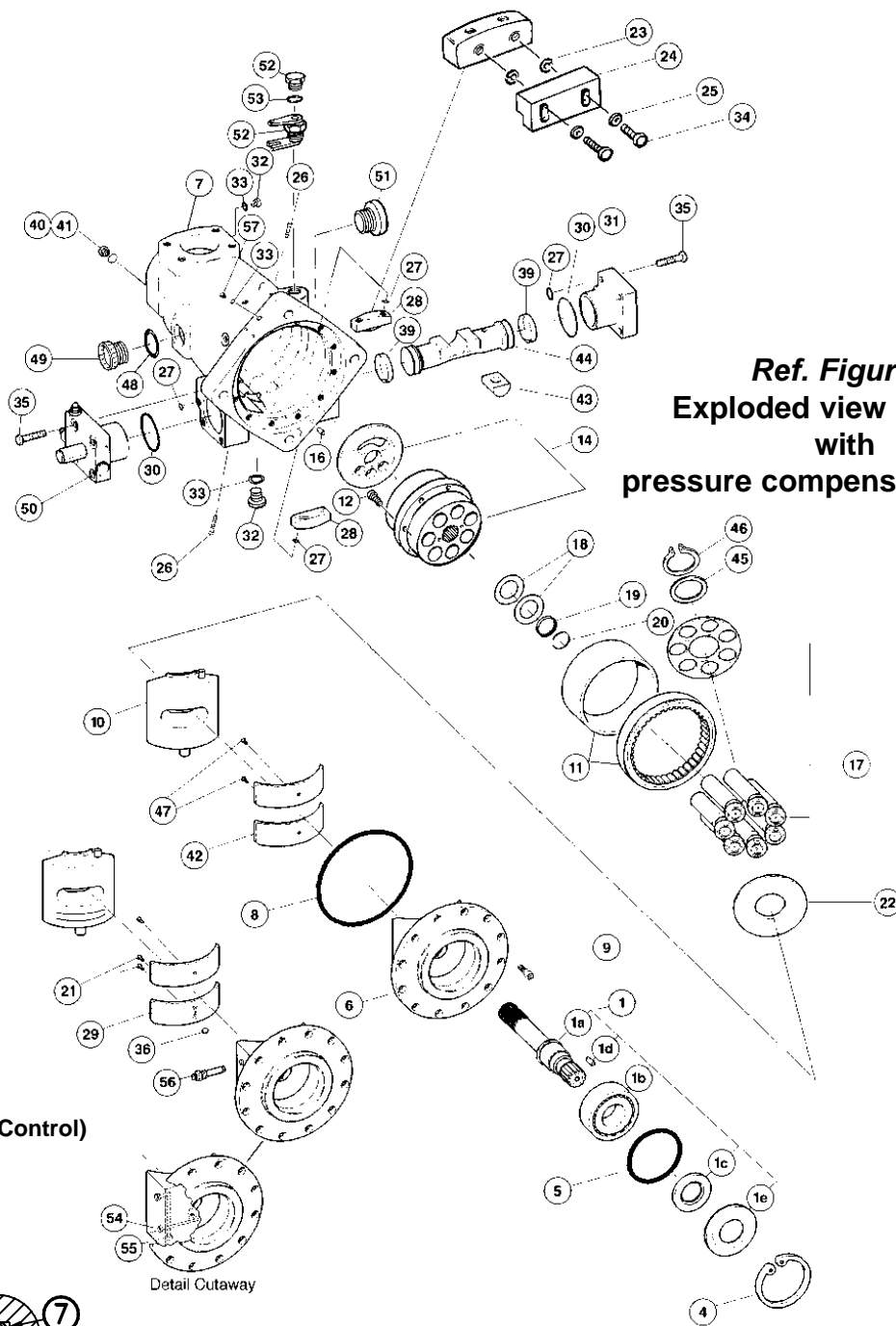

Ref. Figure 1
Exploded view of pump
with
pressure compensator control

(For PQ Control)

Detail Cutaway

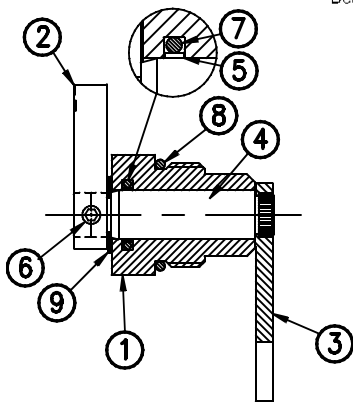

Ref. figure 2
Indicator Assembly (52)
S22-15944

PARTS LIST FOR INDICATOR ASSEMBLY

item	description	part no.	qty.
1	Pivot nut	032-92491	1
2	Indicator	033-70624	1
3	fork	032-92489	1
4	pivot shaft	032-92492	1
5	glyd ring	679-00030	1
6	Soc. setscrew, 10-32 x 3/16	312-09030	1
7	O-ring, 70 S-1 ARP 114	671-00114	1
8	O-ring, 90 S-1 ARP 914	691-00914	1
9	Retaining ring	356-65070	1

PUMP PARTS LISTS

item	description	part no. P09-SAE	part no. P140-ISO	qty.
18	Belleville washer	032-91597	032-91597	2
19	stop	032-91596	032-91596	1
20	retaining ring	032-91595	032-91595	1
21	screw, button head (PQ control)	353-25079	353-25079	2
22	wear plate	032-91598	032-91598	1
23	lockwasher	348-10016	348-10016	2
24	bearing	032-91602	032-91602	1
25	washer	345-10012	345-10012	2
26	screw, SHC	361-08200	361-08200	4
27	O-ring, 90 S-1 ARP 013	691-00013	691-00013	6
28	cam/bearing retainer	032-91600	032-91600	2
29	bearing, hydrostatic cam (PQ control)	032-92808	032-92808	
30	O-ring, 70 S-1 ARP 152	671-00152	671-00152	2
31	off stroke control side (see page 17)			1
	buck-up cap (comp, torque limiter, load sensing)	S22-15653	S22-15653	
	electric stroker	S22-16001	S22-16002	
	hydraulic stroker	S22-16003	S22-16004	
	rotary servo	S22-16005	S22-16006	
	PQ control	S22-15963	S22-15964	
32	plug, SAE-4, 1/4 BSPP	488-35061	447-01004	2
33	O-ring, 90 S-1 ARP 904	691-00904	none	3
34	screw, SHC	361-08704	361-08704	2
35	Screw, HHC, M12 x 1,75 x 60 mm lg.	363-12210	363-12210	*
	Screw, HHC, M12 x 1,75 x 80 mm lg. (E,H,R,J,K)	363-12225	363-12225	*
	Screw, HHC, M12 x 1,75 x 90 mm lg. (L)	363-12240	363-12240	*
36	O ring, 70 S-1 ARP 010 (PQ control)	671-00010	671-00010	1
39	ring (qty. 1 for servo, electric & hyd. stroker)	032-92856	032-92856	2
	ring (servo, electric & hydraulic stroker)	032-92855	032-92855	1
40	O-ring, 90 S-1 ARP 906	691-00906	none	1
41	plug, SAE-6, 1/4 BSPP	488-35041	447-01004	1
42	bearing (qty 1 for PQ control)	032-91590	032-91590	2
43	slide link	032-91579	032-91579	1
44	control piston (compensator, torque limiter)	032-91585	032-91585	1
	control piston (servo, electric & hydraulic stroker)	032-91881	032-91881	
	control piston (PQ control)	032-92694	032-92694	
45	bearing	032-91599	032-91599	1
46	retainer, blue, .061", 1,55 mm thick	032-91894	032-91894	1
	retainer, red, .059", 1,50 mm thick	032-91895	032-91895	
	retainer, green, .057", 1,45 mm thick	032-91896	032-91896	
	retainer, yellow, .055", 1,40 mm thick	032-91897	032-91897	
	retainer, white, .053", 1,35 mm thick	032-91898	032-91898	
47	screw, FSHCS (qty 1 for PQ control)	316-50001	316-50001	2
48	O-ring, 90 S-1 ARP 920	691-00920	none	1
49	plug, SAE-20, 1-1/2 BSPP	488-35019	447-00034	1
50	on stroke control side (see page 17)			1
	compensator	S22-15311	S22-15312	
	low torque limiter	S22-15734	S22-15735	
	high torque limiter	S22-15313	S22-15314	
	load sensing	S22-15536	S22-15537	
	low torque limiter with load sensing	S22-16193	S22-16194	
	high torque limiter with load sensing	S22-15790	S22-15802	
	compensator override	S22-16007	S22-16008	
	low torque limiter override	S22--16009	S22-16010	
	high torque limiter override	S22-16011	S22-16012	
	control cap, servo	S22-15256	S22-15272	
	maximum volume stop, PQ control	S22-16126	S22-16126	
51	shipping plug	449-00020	449-00611	
52	plug, SAE-14	488-35030	488-35030	1
	indicator assembly (see figure 2)	S22-15944	S22-15944	
53	O-ring, 90 S-1 ARP 914	691-00914	691-00914	1
54	plug, 1/4 pipe (PQ control)	431-90404	431-90404	1
55	plug, 1/16 pipe (PQ control)	431-90104	431-90104	1
56	fitting, pass through (PQ control)	S22-16384	S22-16384	1
57	plug, SAE-4, 1/8 BSPP	488-35061	447-01002	1
	Seal Kit	S22-15084	S22-15085	
	Seal Kit, with "X" control	S22-16479	S22-16480	

*see controls section for quantity

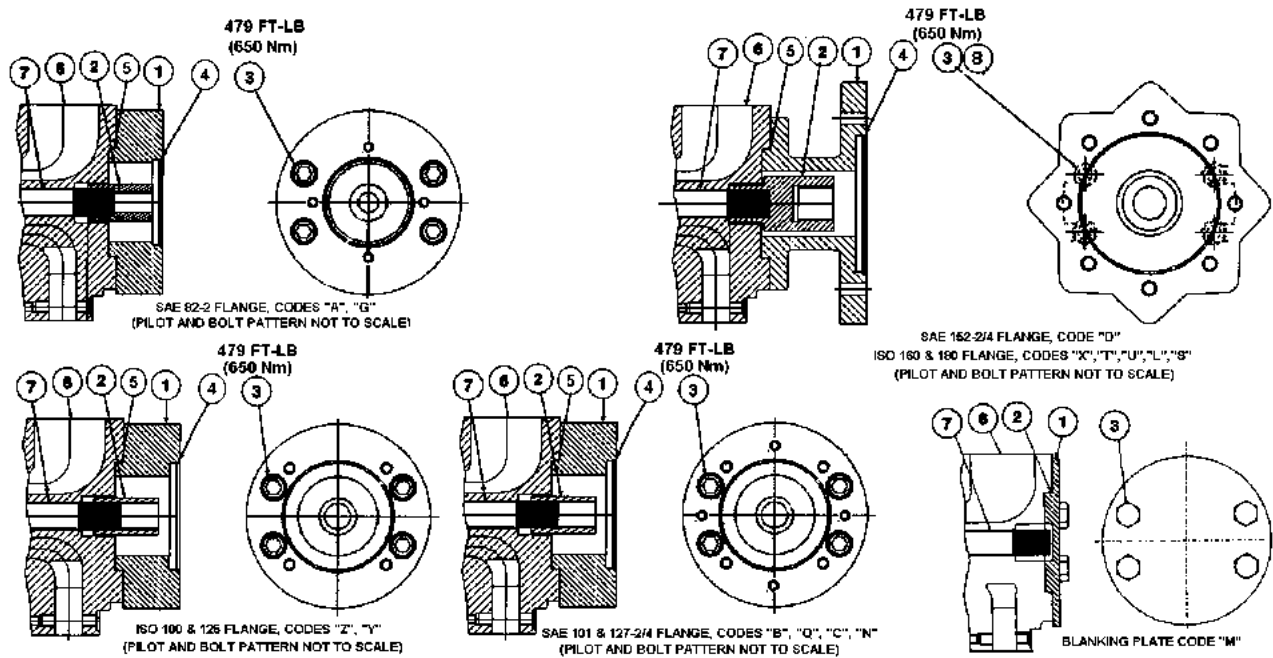

Figure 3
Rear drive options

SAE REAR DRIVES									
			code → A	G	B	Q	C	N	D
			flange → SAE 82-2	SAE 82-2	SAE101-2/4	SAE101-2/4	SAE127-2/4	SAE127-2/4	SAE152-4
			coupling → 16-4	22-4	22-4	25-4	32-4	38-4	44-4
item	part	qty	("A")	(modified "A")	("B")	("B-B")	("C")	("C-C")	("D")
1	adapter	1	032-91900	032-91900	032-91309	032-91309	032-91308	032-91649	032-91282
2	coupling	1	032-91901	032-92377	032-91361	032-91362	032-91363	032-91648	032-91364
3	screw	4	361-16304-8	361-16304-8	361-16304-8	361-16304-8	361-16304-8	361-16304-8	363-16250
4	O-ring	1	671-00152	671-00152	671-00155	671-00155	671-00159	671-00159	671-00163
5	O-ring	1	671-00159	671-00159	671-00159	671-00159	671-00159	671-00159	671-00159
8	washer	4							350-10109
	assembly		S22-15372	S22-15809	S22-12867	S22-12868	S22-12869	S22-12920	S22-12870

ISO REAR DRIVES									
			code → Z	Y	X	T	U	L	S
			flange → ISO 100	ISO 125	ISO 160	ISO 180	ISO 180	ISO 180	ISO 180
			coupling → ISO K25N	ISO K32N	ISO K40N	ISO K40N	ISO K50N	DIN 40-18	DIN 50-24
item	part	qty							
1	adapter	1	032-91383	032-91384	032-91385	032-92162	032-92162	032-92162	032-92162
2	coupling	1	032-91391	032-91390	032-91389	032-91389	032-91388	032-92345	032-92346
3	screw	4	361-16304-8	361-16304-8	363-16250	361-16304-8	361-16304-8	361-16304-8	361-16304-8
4	O-ring	1	671-00155	671-00159	671-00164	671-00167	671-00167	671-00167	671-00167
5	O-ring	1	671-00159	671-00159	671-00159	671-00159	671-00159	671-00159	671-00159
8	washer	4			350-10109	350-10109	350-10109	350-10109	350-10109
	assembly		S22-12872	S22-12873	S22-12874	S22-15740	S22-15570	S22-15933	S22-15934

note: item (1) blanking plate part no. 032-91468 item (3) blanking plate screws 363-16210-8

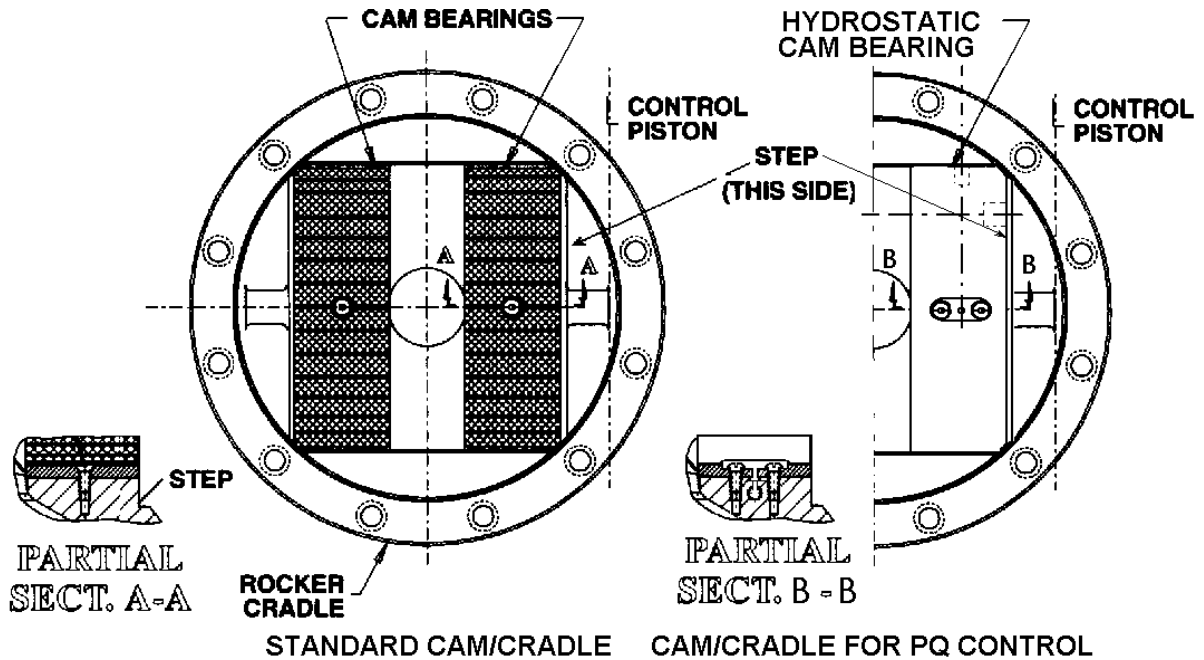

Figure 4
CAM BEARINGS/CRADLE ORIENTATION TO HOUSING

ROTATION CONVERSION

The following parts and assembly are required for changing shaft rotation:

- A different barrel and port plate assembly is required. The barrel and port plate are matched assemblies, and should not be ordered separately. The reference part numbers are:
 CW - Barrel and Port Plate Assembly S22-16147 S22-16386 (PQ control)
 CCW - Barrel and Port Plate Assembly S22-16148 S22-16387 (PQ control)
- The control piston must be reversed to position it correctly to the control caps. (See step 9 pg. 20)
- The control caps location are reversed. *see illustration below.*

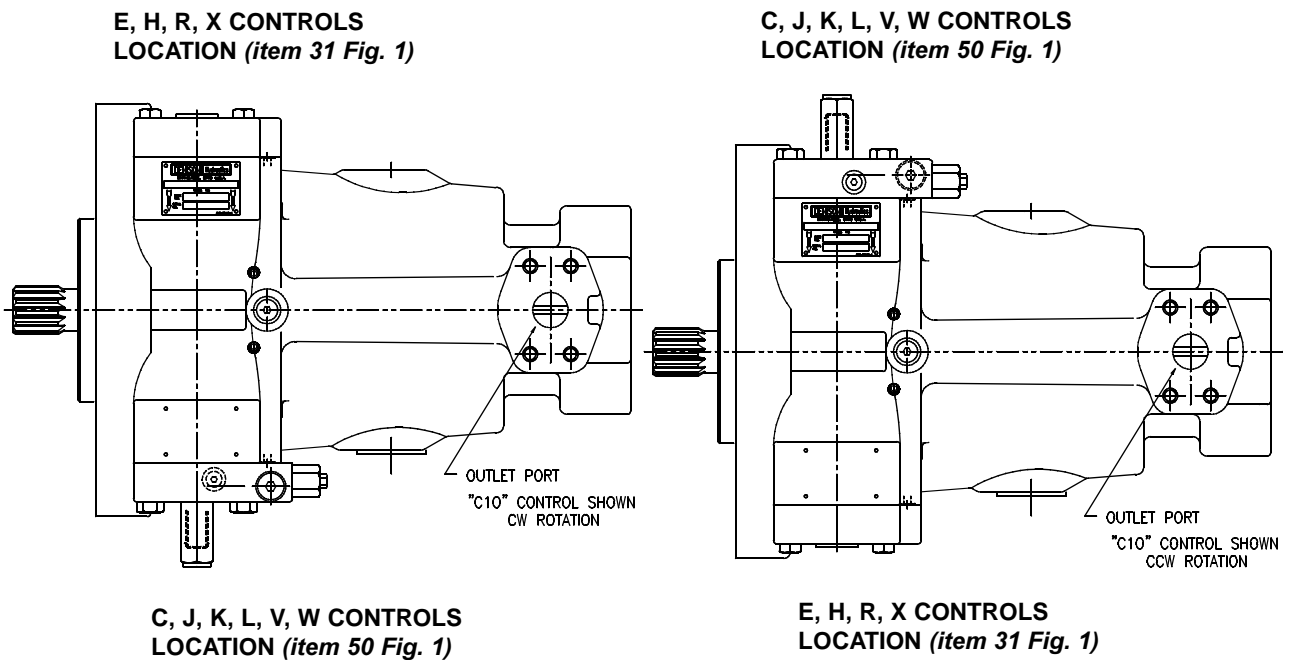

Figure 5
CONTROL ORIENTATION VERSUS PUMP ROTATION

SHAFT SEAL REPLACEMENT

See illustration. Remove worn or damaged seal from retainer. Clean gasket sealant from retainer.

Install new seal by applying gasket sealant to retainer and pressing seal in retainer.

SEAL KITS	P09	S22-15084
.....	P140	S22-15085
SEAL KITS (WITH "X" CONTROL)	P09	S22-16479
.....	P140	S22-16480

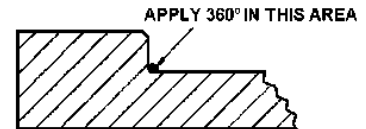

The shaft seal and all "O" rings necessary for total seal replacement may be obtained

by ordering the Seal Kit . These seals are suitable for petroleum base fluids. For fire resistant fluids contact **DENISON HYDRAULICS**, Inc. or their authorized distributors to obtain the appropriate seal kit number.

SHAFT ASSEMBLIES

The following assemblies include shaft, key when applicable, bearing and seal:

	P09-SAE #	P140-ISO #
Keyed, no rear drive assembly	S22-15111	S22-15115
Keyed, with rear drive assembly	S22-15112	S22-15116
Splined, no rear drive assembly	S22-15113	S22-15117
Splined, with rear drive assembly	S22-15114	S22-15118
		P140-DIN #
Keyed, no rear drive assembly		S22-15685
Keyed, with rear drive assembly		S22-15686
Splined, no rear drive assembly		S22-15621
Splined, with rear drive assembly		S22-15622

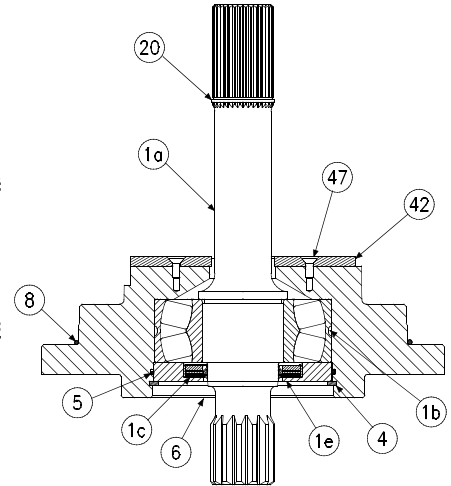

PRE-ASSEMBLY

Depending on the repairs, many steps in this section may not be applicable.

The assembly area should be clean and the environment such that foreign matter will not be introduced to the pump during assembly. All parts must be absolutely clean and free from rust, contamination, lint, or any other foreign matter. Critical surfaces must be free of dings or scratches. All "O" rings and seals must be clean and carefully examined for cuts or other damage before installation.

During assembly, occasional reference will be made to the use of lubricating oil for proper assembly. It is important that any oil used be compatible with the seals and fluid to be used in operation. Compatibility is also necessary for grease which should be used on all "O" rings to ensure proper assembly without damage.

Several screws require a thread lock liquid for locking in position. When required use Loctite® #242 unless otherwise specified.

ASSEMBLY

Refer to illustration, see figure 1

See page 26 for tightening torque on plugs

1. Place the port block end of the housing (7) on a suitable surface capable of supporting the pump weight of 220 lbs, 100 Kgs.
2. Install plugs (32), (41) and (54) with "O" rings into port block.
3. Install pin (16) in port block. Position port plate (14) on port block and over pin. To view correct port plate for shaft rotation specified, **See illustration, below**

Port Plate for CW Shaft Rotation (Ref. Barrel and Port Plate Assembly S22-16147) **Port Plate for CCW Shaft Rotation** (Ref. Barrel and Port Plate Assembly S22-16148)

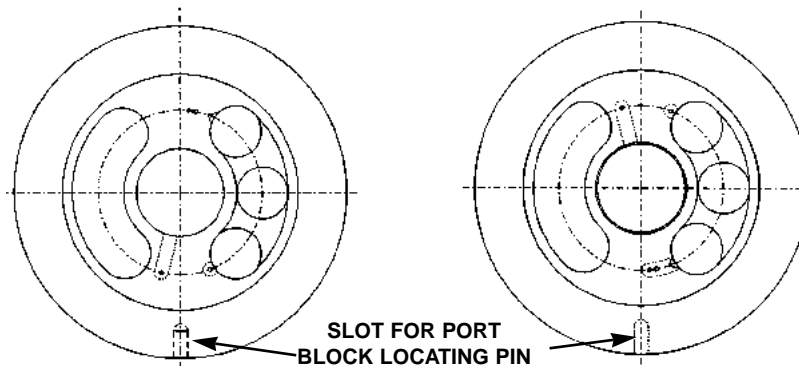

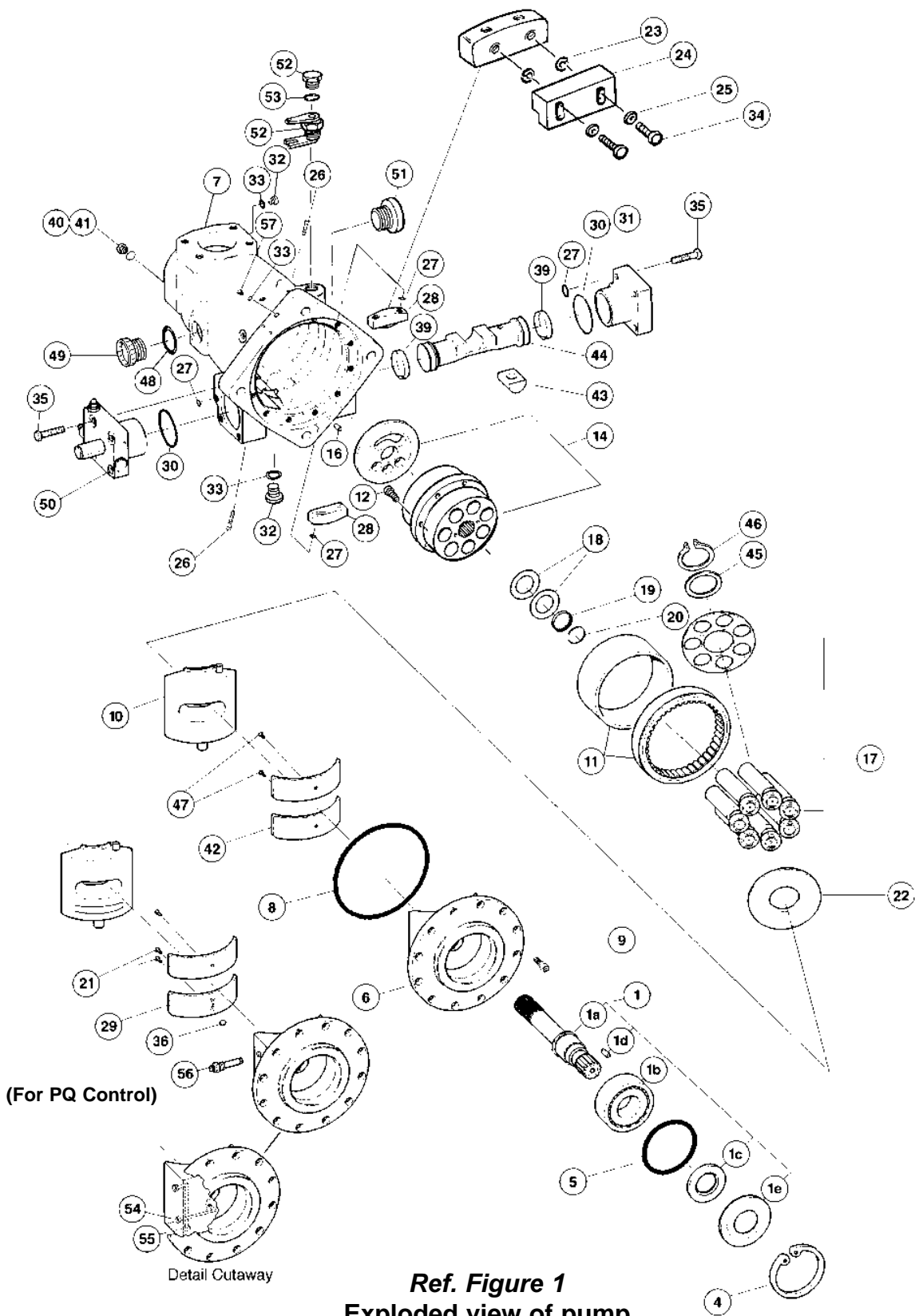

Ref. Figure 1
Exploded view of pump
with
pressure compensator control

- Press bearing outer race (11) into housing (7).

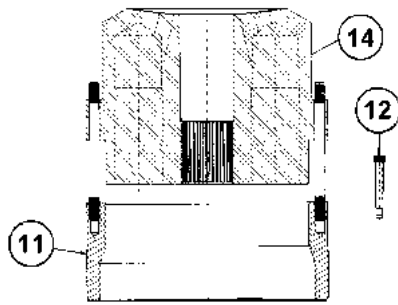

BARREL AND INNER RACE ASSEMBLY

- Thread seven M8-1,25 studs into bearing inner race. Lower barrel (14) over studs and seat. If the inner race is heated to 150°F, 65°C, barrel will slide into position without force. If race is not heated, longer screws (12) can be used to draw the race and barrel together. Insert screws (12) and torque to 30 lbs ft., 40 Nm. *See illustration*
- Apply oil to face of port plate and inner bearing race. Attach tool T-1 to barrel with two M6 screws. Carefully lower barrel assembly into housing engaging inner race into rollers of outer bearing race, barrel may then be lowered until it is seated on port plate.
- Insert two "O" rings (27) into each retainer (28). Apply thread locking compound to two screws (26) and secure retainer to housing. Torque to 84 lbs-in., 9,5 Nm.
- Apply thread locking compound to two screws (26) and assemble the other retainer on opposite side of housing. Torque to 84 lbs-in., 9,5 Nm.
- Assemble the two piston rings (39) on control piston (44). Insert control piston (44) into housing bore that is used with the control caps. **For CW shaft rotation**, the long end of the piston must be positioned to the right. (*Ref. fig.1*) **For CCW rotation**, the long end of the piston is to the left.
- Position Belleville washers (18) on barrel, *See illustration*. To insure proper pump operation and correct barrel holddown force they must be assembled exactly as shown. Place barrel stop (19) on Belleville washers and center the washers and stop on barrel.

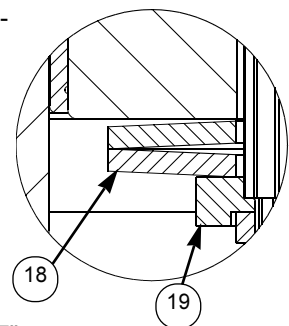

CAM ASSEMBLY

- Set cam assembly (10) on suitable surface protecting cam surfaces from damage during assembly. *See illustration*
- Place wear plate (22) on cam.
- Position pistons-shoes-retainer assembly (17) over center post and against wear plate.
- Install thrust washer (45) over center post.
- Five different retainers (46) are available for setting the shoe holddown. Each retainer is marked: **white dot** .053", 1,35 mm thick, **yellow dot** .055", 1,40 mm thick, **green dot** .057", 1,45 mm thick, **red dot** .059", 1,50 mm thick, and **blue dot** .061", 1,55 mm thick. Install the thickest retainer with the dot side up, that will fit in the groove on the center post and allow a clearance of .003"-.005", 0,076-0,127 mm between the shoe and wear plate. **A .003", 0,076 mm feeler gage must go completely under any shoe, and a .005", 0,127 mm feeler gage must not go under any shoe while holding a piston and lifting tightly against the shoe retainer.** The piston and shoe assembly must be free to rotate easily by hand. Rotate 360° to confirm there is no binding and that each shoe is free in the retainer plate. Oil the assembly thoroughly.

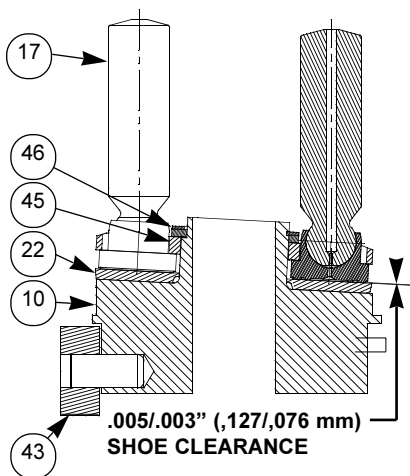

- Install slide link (43) on rocker cam pin as shown.
- Oil barrel bores before installing cam assembly. The piston must be moved outward (*away from pump center*) so that clearance is provided for installing the rocker cam assembly. Lower cam assembly into the housing with the slide link positioned so it will engage into the control piston (44). The seven pistons (17) must first be engaged into the barrel bores. Next the slide link (43) must engage into the control piston (44). Continue lowering rocker cam assembly until it is seated on cam/bearing retainers (28).

- Apply thread locking compound to two screws (34) and assemble clearance-bearing (24) to cam-bearing retainer (28) using the screws (34), two washers (25) and two washers (23). Move rocker cam to the right until it is against stop. **Set clearance** between clearance bearing (24) and cam at .006", 0,152 mm. Torque screws to 6 lbs-ft., 8,1 Nm maintaining the .006", 0,152 mm clearance.

- Adjust piston (44) toward the *off stroke* control side (31). This will place the cam at approximately zero displacement and provide clearance for the shaft installation.

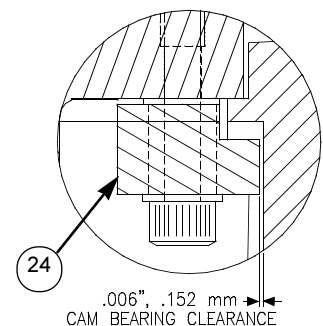

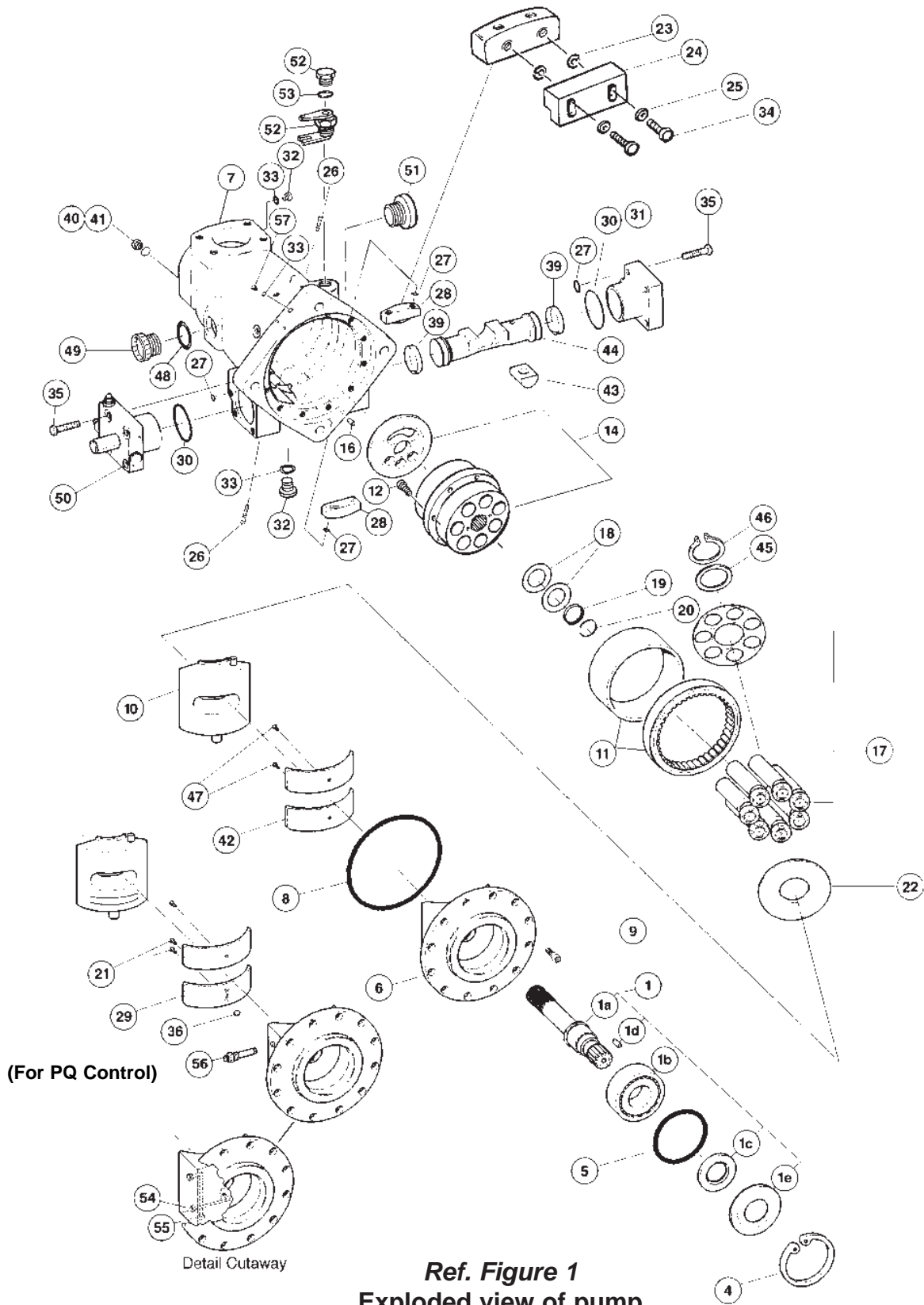

Ref. Figure 1
Exploded view of pump
with
pressure compensator control

- Continued -

Rocker cradle assembly

20. Apply threadlocking compound to two screws (47) and assemble two cam bearings (42) to cradle (6). Torque to 33 lbs-in., 3,8 Nm.

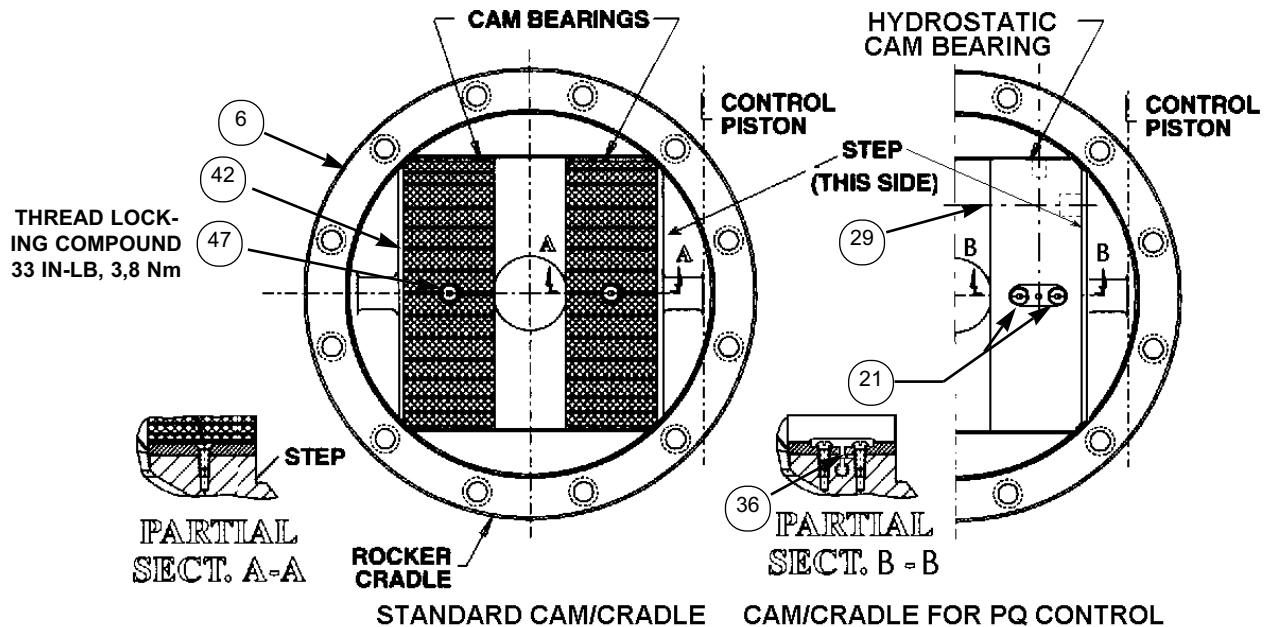

- 21. Press bearing (1b) on shaft (1a). Press on inner race only.
- 22. Apply over 360° bead of gasket sealant to seal retainer (1e) per following sketch. Press shaft seal (1c) into seal retainer (1e).
- 23. Install shaft seal and retainer on shaft using Tool T-4 to protect seal.
- 24. Install "O" ring (5) in cradle (6).
- 25. Press seal retainer and bearing and shaft assembly into bore of cradle (6) using Tool T-3.
- 26. Install snap ring (4) to cradle.
- 27. Install "O" ring (8) to rocker cradle.

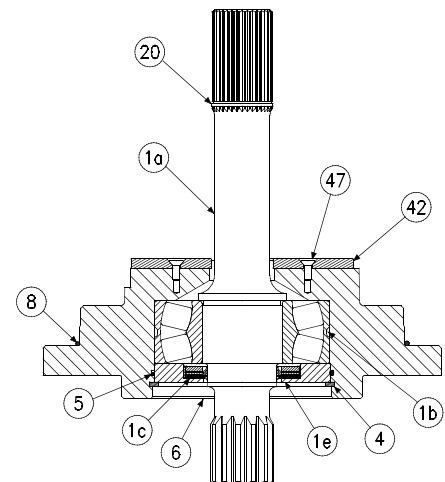
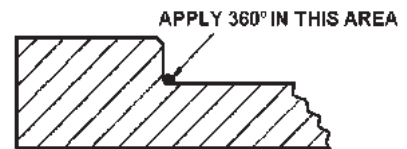

- 28. Install retaining ring (20) on shaft.
- 29. Center Belleville washers and barrel stop. Lower rocker cradle assembly into pump housing with the step in the rocker cradle correctly positioned so that clearance is provided for slide link (43). The 3/8-16 threaded hole in the end of shaft should be used to support the assembly. The shaft spline must first engage the splined barrel stop (19), thru the Belleville washers (18) and engage the barrel spline. The assembly will then rest on the cam.
- 30. Install socket head cap screws (9) as shown. Torque evenly to 57 ft-lb (77 Nm). Install case drain plug (49) and shipping plug (51). If pump does not contain stroke indicator, install plug (52) and "O" ring (53) in indicator hole.
- 31. If installing "X" model pump, install pass thru fitting (56) into housing, being careful that O-ring enters hole in cradle without damage.

INDICATOR ASSEMBLY OPTION

See figure 2. To install indicator assembly, loosen setscrew (6), remove indicator (2) and slide shaft out of nut (1). Guide fork into indicator hole in housing to engage the pin on the hanger. a 1/4-20 SHCS or threaded rod may be used to hold the shaft. Slide nut (1) over shaft and tighten nut in threaded hole. Pull shaft out to slip retaining ring (9) into groove in shaft. Use maximum volume stop to set pump on zero stroke (8.1 turns from full). Install indicator, set pointer on "0" and lock in position.

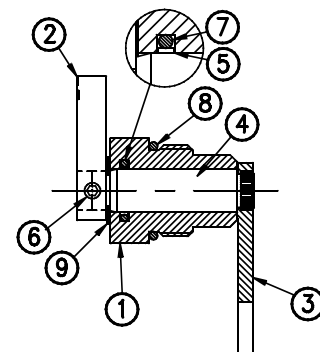

ref. Figure 2
Indicator assembly

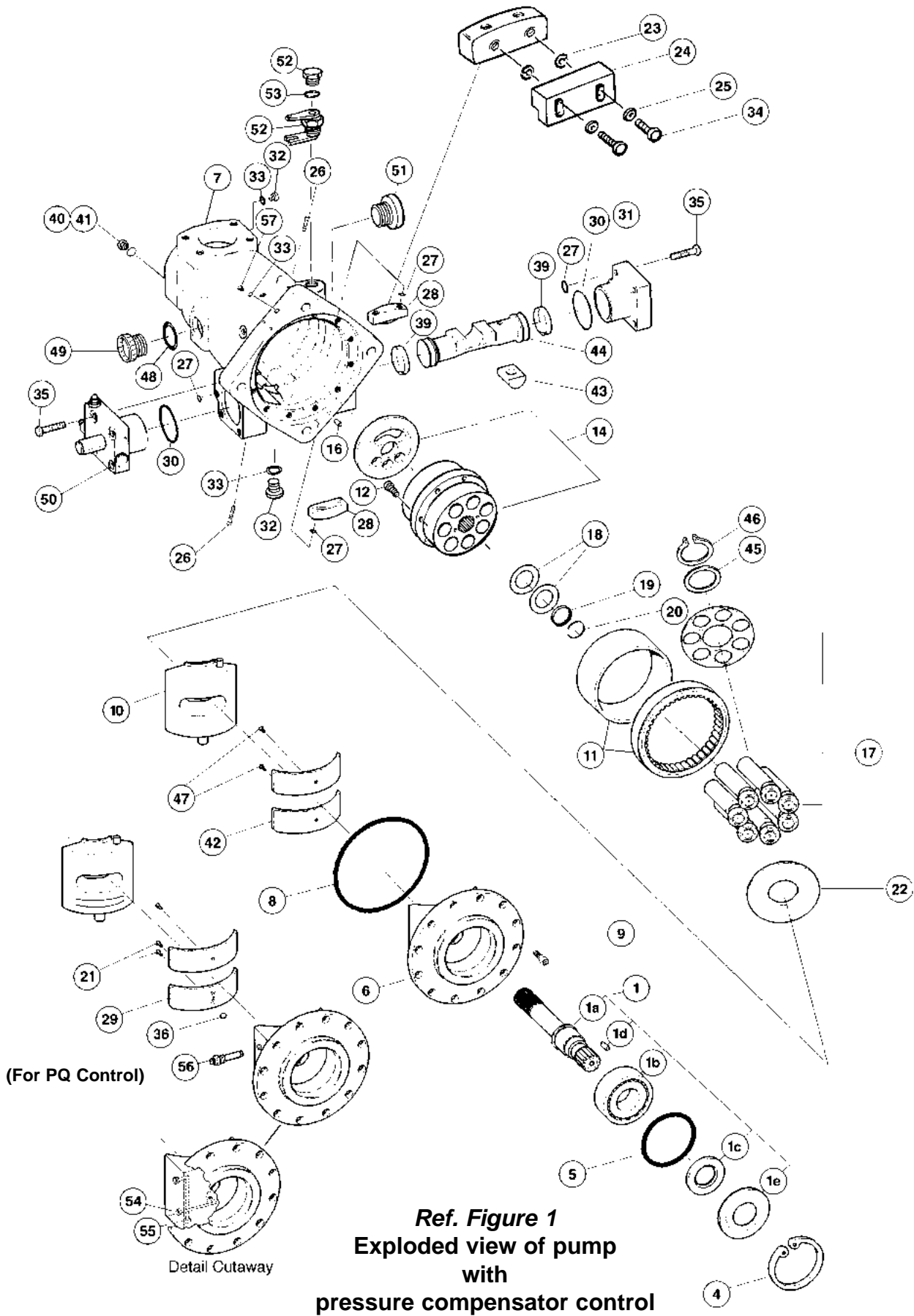

CONTROLS ASSEMBLY

Remove cap tools T-2 from housing and replace with control cap assemblies (50) and (31). The control caps must be positioned on the housing for either CW or CCW pump rotation. See figure 5 for correct orientation. The control piston (44) was assembled previously for the correct pump rotation. Install eight hex head cap screws (35) into caps and torque to housing with 75 lbs-ft., 102 Nm.

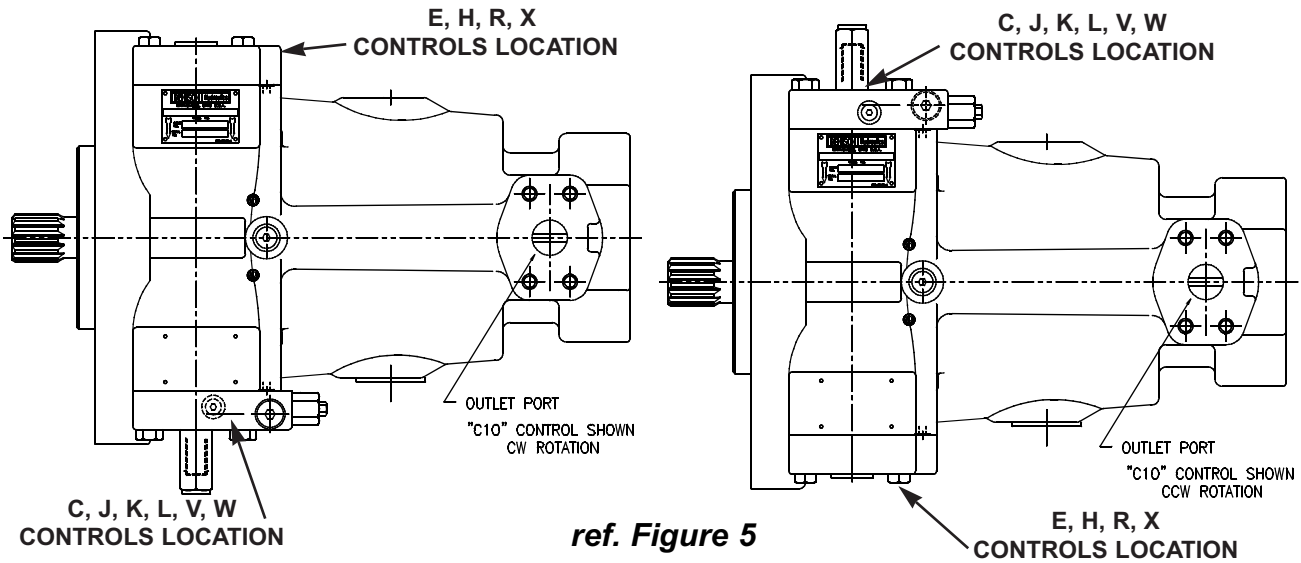

If the pump has a rear drive feature, assemble coupling and adapter. See illustration, figure 3.

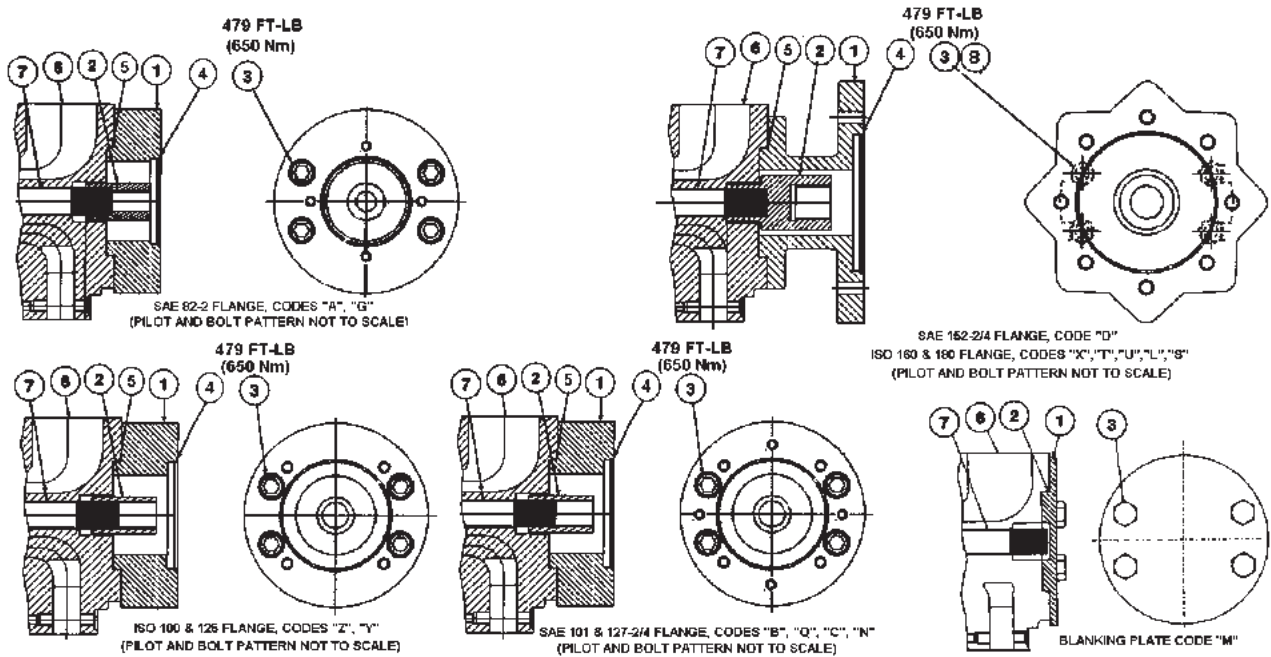

GENERAL

The instructions contained in this manual cover complete disassembly and reassembly of the controls. Before proceeding with the disassembly or reassembly of any unit, this manual should be studied in order to become familiar with proper order and parts nomenclature.

DESCRIPTION OF OPERATION

A pilot operated valve spool and sleeve combination is the core of the control function. For the compensator, torque limiter and load sensing controls, system pressure is applied to the input port of a three-way valve, and to one end of the valve spool. A small orifice feeds this pressure to the other end of the spool, and limits pilot flow to approximately 115 in³/min., 1,9 lpm. A spring on this end biases the spool to normally port the control piston to pump case. This control piston links to the pump cam. On the opposite end of the control piston a small buck-up piston connects to system pressure. This force, pump timing forces, and a spring combine to put the pump on stroke.

PRESSURE COMPENSATOR

A spring-loaded cone and seat connected to the spring end of the three-way spool establishes an adjustable pressure limit on this end of the spool. When system pressure reaches this value, flow through the spool creates a pressure difference across the spool. At approximately 250 psi, 17,2 bar difference, the spool shifts toward the spring, re-directing the control piston port to system pressure. This pressure applied to the control piston overcomes the forces putting the pump on stroke, causing the pump to reduce displacement. When the pump pressure drops, the spool meters to maintain the pump pressure at approximately 250 psi, 17,2 bar above the controlled pressure on the spring side. The spring end of this three-way spool may also be connected to a remote pressure control, through the vent port, "V".

LOAD SENSING CONTROL

In the load sensing control, the system load pressure is applied to a modulating valve which establishes the compensator vent pressure at 200 psi, 13,8 bar above load pressure. Adding the differential pressure across the compensator spool to this pressure, the pump outlet pressure is approximately 350 psi to 450 psi, 24,1 to 31 bar above load pressure. There is essentially no flow in the sensing line, and the pump supplies the flow required to develop 350 psi to 435 psi, 24,1 to 30 bar across the metering valve to the load.

TORQUE LIMITER

The input torque is limited to a set value with the torque limiter control. To limit input torque, pump displacement is reduced when pressure increases, and vice versa. This is accomplished by controlling the compensator pilot pressure with a linkage to the pump stroking piston.

The compensator vent connects to one end of a pin which is spring loaded on the other end. The pin slides through a spool which is positioned by a linkage to the control piston. Vent flow passes through the pin to a cross drilled hole, which is opened or blocked by the motion of the spool. As system pressure increases, the pin moves against the springs till the cross drilled passage opens, venting the compensator and causing the pump to reduce displacement. As displacement reduces, the sleeve follows, closing the cross drilled passage and establishing the control at a higher pressure. For any pressure, there is a corresponding pump displacement. The position of the spool is controlled by the pressure acting against two springs, one which is always in contact with the pin, and the other which comes in contact as pressure increases, providing an increase in spring rate as pressure increases.

TORQUE LIMITER WITH LOAD SENSING

By attaching the load sensing modulator valve to the torque limiter cap, a control with torque limiting, load sensing and compensator override functions is possible.

ROTARY SERVO CONTROL

The rotary servo control is mounted on the off-stroke side of the control piston. Servo pressure is connected to the input port of a four-way valve, and to one end of this valve spool. A drilling and orifice connects to the opposite end of the spool. One cylinder port connects to the "off stroke" end of the control piston, while the other cylinder port connects to the "on stroke" end of the control piston, through the control on the opposite side.

A rotatable shaft converts to a linear motion on a pin. A sleeve over the pin is driven by a linkage to the control piston. The sleeve/pin combination meters pilot flow from the four-way valve, controlling the shifting of the four-way valve, in such a manner that the four-way valve shifts to hold the cylinder position to the corresponding position for the input rotation.

HYDRAULIC STROKER

In the hydraulic stroker, the pin which controls stroke position is connected to a spring loaded piston. A control pressure of 50 psi, 3,45 bar causes the piston to commence to move against the spring, to position the pin in proportion to the control pressure, and thus cause the pump to stroke in proportion to control pressure. Full stroke is achieved at 245 psi, 16,9 bar.

ELECTRIC STROKER

By mounting an electrically modulated pressure control valve on the hydraulic stroker to establish the control pressure, pump stroke is controlled by an electrical signal. For a 24 volt coil, the pump commences to stroke at approximately 175 mA electrical signal, and will be at full stroke at approximately 283 mA.

PRESSURE COMPENSATOR AND TORQUE LIMITER OVERRIDE

An override pressure compensator or a torque limiter control mounts on the smaller diameter of the control piston, opposite the servo, hydraulic or electric stroker. In the normal position, the spool in the override control connects this piston to the control valve on the opposite side, allowing control by the stroker. When system pressure or torque exceed the override setting, this spool connects system pressure to the smaller diameter control piston, to override the rotary servo, hydraulic or electric stroker command and reduce stroke according to the compensator or torque limiter setting. Override pressure must be sufficient to overcome servo pressure acting on the larger diameter piston.

PQ HIGH RESPONSE CONTROL

A proportional valve with spool position feedback directs oil to and from one end of the control piston, while an RVDT measures stroke position to provide high speed response control of pump stroke when connected to the driver card S22-14133. With system pressure feedback, control of torque input to the pump is also possible with this driver card.

PORT SIZES

.....DESCRIPTION.....	P09	.P140
PORT C1OFF-STROKE CYL. GAGE.....	SAE-4	1/4 BSPP
PORT C2ON-STROKE CYL. GAGE	SAE-4	1/4 BSPP
PORT DCASE DRAIN	SAE-20	1-1/2 BSPP
PORT D1CASE DRAIN	SAE-20	1-1/2 BSPP
PORT DG.....DRAIN GAGE, AIR BLEED PORT	SAE-4	1/8 BSPP
PORT AG.....INLET GAGE	SAE-4	1/4 BSPP
PORT BG.....SYSTEM GAGE.....	SAE-4	1/4 BSPP
PORT BG1....ALT. SYS. GAGE.....	SAE-6	1/4 BSPP
PORT EELECTROHYDRAULIC STROKER SERVO SUPPLY	SAE-4	1/4 BSPP
PORT HHYDRAULIC STROKER SIGNAL	SAE-4	1/4 BSPP
PORT LSLOAD SENSING LINE	SAE-4	1/4 BSPP
PORT VCOMPENSATOR, TORQUE LIMITER, LOAD SENSING VENT	SAE-8	3/8 BSPP
PORT V1SERVO VENT	SAE-4	1/4 BSPP
PORT XSERVO SUPPLY	SAE-8	3/8 BSPP
PORT XGSERVO GAGE	SAE-10	1/2 BSPP

PRESSURE COMPENSATOR CONTROL

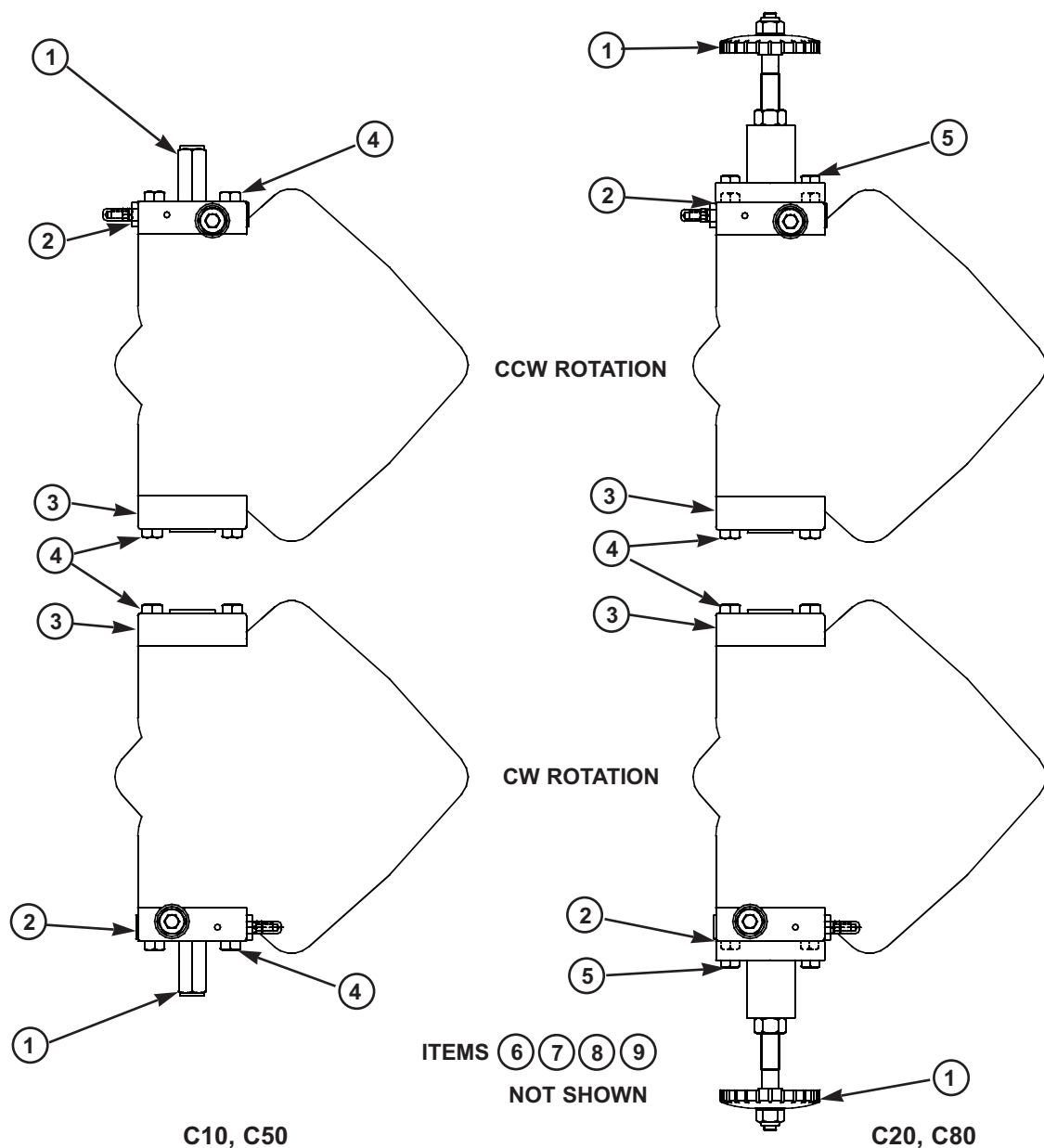

PRESSURE COMPENSATOR

parts list

ITEM	DESCRIPTION	P09 PART NO.	P140 PART NO.	QTY.	
				C10, C50	C20, C80
1	Max. Vol. Stop (Fig. 7)	S22-12983	S22-12983	1	—
	Max Vol. Handwheel (Fig. 8)	S22-12915	S22-12915	—	1
2	*Compensator Control (Fig. 6)	S22-15311	S22-15312	1	-
3	Buck Up Cap (Fig. 9)	S22-15653	S22-15653	1	1
4	Screw-H.H.C., M12 x 60 mm	363-12210	363-12210	8	6
5	Screw-H.H.C., M12 x 80 mm	363-12225	363-12225	—	2
6	Control Piston	032-91585	032-91585	1	1
7	O-Ring, 90 S-1 ARP 013	691-00013	691-00013	2	2
8	O-Ring, 70 S-1 ARP 152	671-00152	671-00152	2	2
9	Piston Ring	032-92856	032-92856	2	2

*Include items 1 (Maximum Volume Stop), 4, 5, 7 and 8

COMPENSATOR DISASSEMBLY

1. **See Figure 6.** Back off max. volume screw or handwheel to full displacement. Remove max. volume screw or handwheel assembly.
2. Remove bolts holding cap to pump.
3. Remove plug (15) and attached parts. Remove spring (11) and spool (18).
4. Remove adjusting plug (2) and attached parts. Remove seal piston (5). Note: a 10-24 screw may be used to assist in pulling the piston. Remove spring (7) and cone (8).
5. Do not remove sleeve in body (1). Sleeve is pressed into cap and finished to size. If sleeve or cap is worn, replace the cap-sleeve assembly (1).
6. Examine seat (10) for wear. Do not remove unless damaged.

ASSEMBLY***See page 3 for tightening torque on plugs***

1. Install plugs (9) and o-rings (3), and orifice (19) in body.
2. Press seat (10) into bore squarely against shoulder in bore.
3. Install spool (18) into bore as shown. Install spring (11) over end of spool. Install plug with stop (16) into plug (15). Install plug (15) into cap.
4. Install O-ring (6) on seal piston (5).
5. Lubricate O-ring and install cone (8), spring (7) and seal piston into bore in cap (1), being careful that cone enters seat (10). Install remaining parts. Torque plugs (12) and (21)
6. Note proper location for cap on pump (pg. 20). Install O-rings on interface between cap and pump control pad.
7. Install cap on pump control pad, guiding the control piston into the bore. Install maximum volume stop assembly.
8. Torque mounting bolts to 75 lbs. ft. (102 Nm).

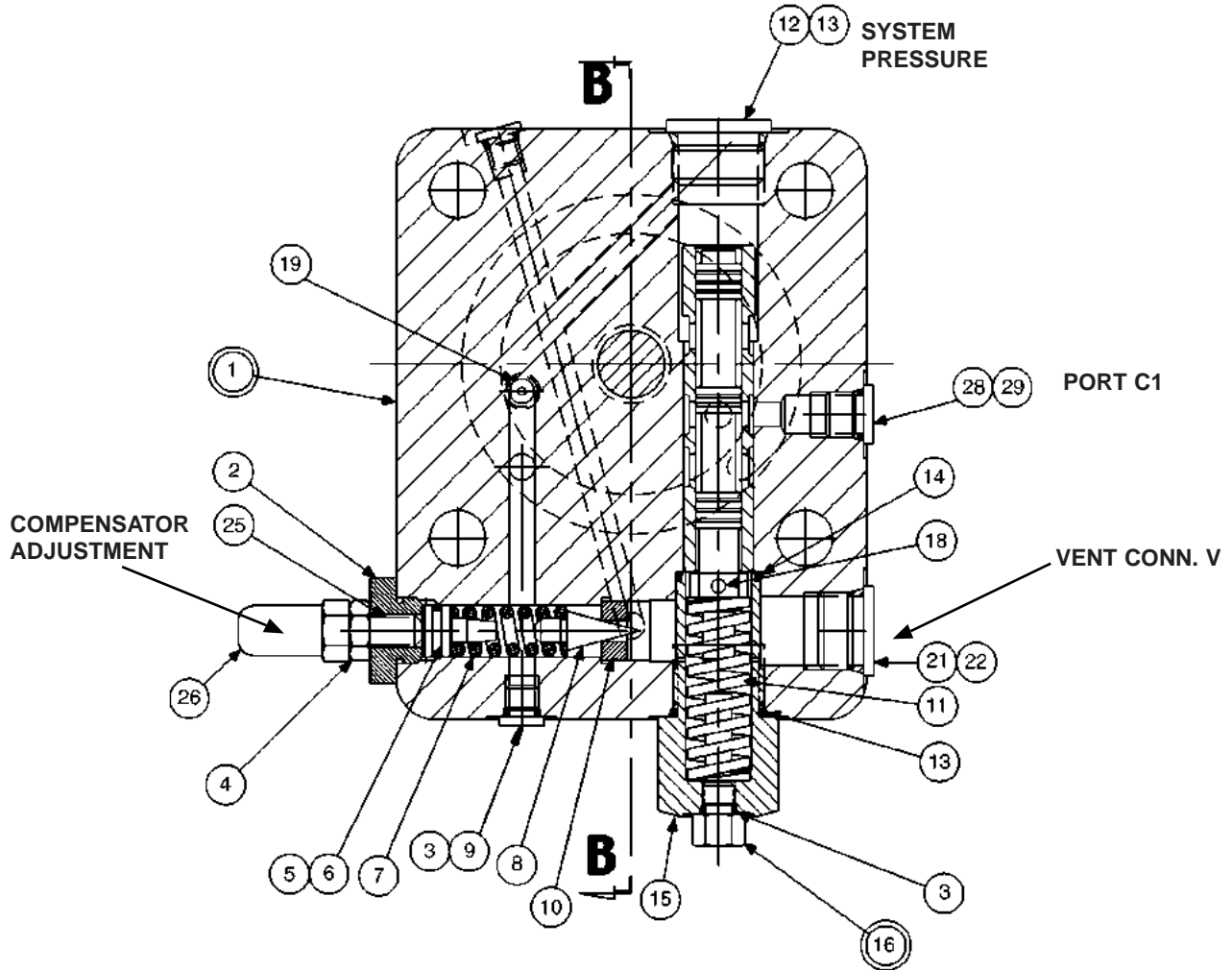

FIGURE 6

PARTS LIST FOR FIGURE 6

P09 code C10, C50 S22-1531

P140 code C10, C50, S22-15312

ITEM	DESCRIPTION	P09		P140	
		PART NO.	QTY.	PART NO.	QTY.
1	Cap-Sleeve Assembly	S22-12880	1	S22-12881	1
2	adjusting Plug	032-91814	1	032-91814	1
3	O-ring, 90 S-1 ARP 902	691-00902	3	691-00902	3
4	Nut, 5/16-24	335-13100	1	335-13100	1
5	Seal Piston	031-59367	1	031-59367	1
6	O-Ring, 90 S-1 ARP 012	691-00012	1	691-00012	1
7	Spring	032-91798	1	032-91798	1
8	Cone	036-12288	1	036-12288	1
9	Plug	488-35046	2	488-35046	2
10	Seat	036-11692	1	036-11692	1
11	Spring	032-92874	1	032-92874	1
12	Plug, SAE-10, (1/2 BSPP)	488-35055	1	447-01008	1
13	O-Ring, 90 S-1 ARP 910	691-00910	2	691-00910	1
14	O-Ring, 90 S-1 ARP 017	691-00017	1	691-00017	1
15	Plug	032-92806	1	032-92806	1
16	Plug with stop	S22-16402	1	S22-16402	1
18	Spool	032-92805	1	032-92805	1
19	Orifice Plug	033-25528	1	033-25528	1
21	Plug, SAE-8, (3/8 BSPP)	488-35018	1	447-00032	1
22	O-Ring, 90 S-1 ARP 908	691-00908	1	-	-
25	Soc. Setscrew 5/16-24 x 1-1/4	312-13180	1	312-13180	1
26	Acorn Nut	036-33474	1	036-33474	1
28	Plug, SAE-4, (1/4 BSPP)	488-35061	1	447-01004	-
29	O-ring, 90 S-1 ARP 904	691-00904	1	-	-

MAXIMUM VOLUME STOP

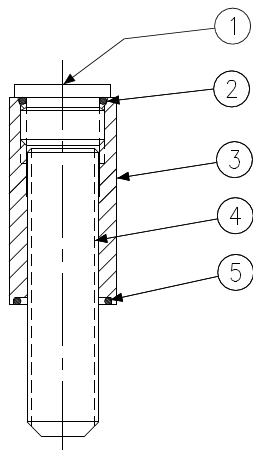

Figure 7
max. volume stop

PARTS LIST FOR FIGURE 7

max. volume stop S22-12983

ITEM	DESCRIPTION	PART NO.	QTY.
1	Plug, SAE-10	488-35055	1
2	O-Ring, 90 S-1 ARP 910	691-00910	1
3	Nut, 3/4 -10UNC Hex	031-91049	1
4	Screw, Soc. Set 3/4 10 x 3	311-26320	1
5	O-Ring,70 S-1 ARP 118	671-00118	1

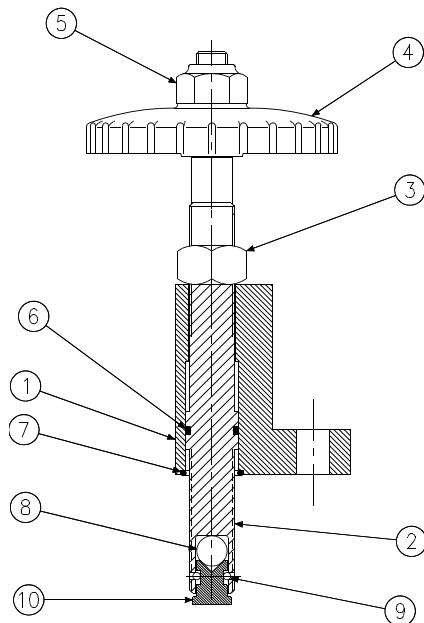

Figure 8
Handwheel maximum volume stop

PARTS LIST FOR FIGURE 8

handwheel S22-12915

ITEM	DESCRIPTION	PART NO.	QTY.
1	Bracket	032-91456	1
2	Screw	032-91455	1
3	Nut, Hex 3/4-16 UNC	333-25000	1
4	Handwheel	031-59911	1
5	Nut, Elastic Stop 1/2-13	331-20100	1
6	O-Ring, 90 S-1 ARP 115	691-00115	1
7	O-Ring, 90 S-1 ARP-118	691-00118	1
8	Ball	201-16001	1
9	Ball	201-04001	2
10	Seat	032-91454	1

MAXIMUM VOLUME HANDWHEEL DISASSEMBLY

1. See Fig. 8. Remove the two screws holding the bracket (1) to the control cap.
2. Turn the handwheel counter-clockwise to remove the stop screw from the control cap.
3. Remove nut (5) and handwheel (4) from the stop screw (2).
4. Remove nut (3). Screw (2) may now be slipped through the bracket (1) to examine parts and to replace O-ring (6).
5. Seat (10) pivots and rotates on ball (8) and is retained by pressing two balls (9) into screw (2). Replace assembly if damaged.

ASSEMBLY

1. Install ball (8) and seat (10) in screw (2).
2. Press balls (9) into screw (2) to retain seat
3. Install O-ring (6) on screw (2). Lubricate O-ring and slide screw into bracket (1). Install remaining parts.
4. Turn handwheel clockwise into cap till the screw contacts the control piston.
5. Install and torque the assembly screws to 75 ft-lb, 102 Nm.

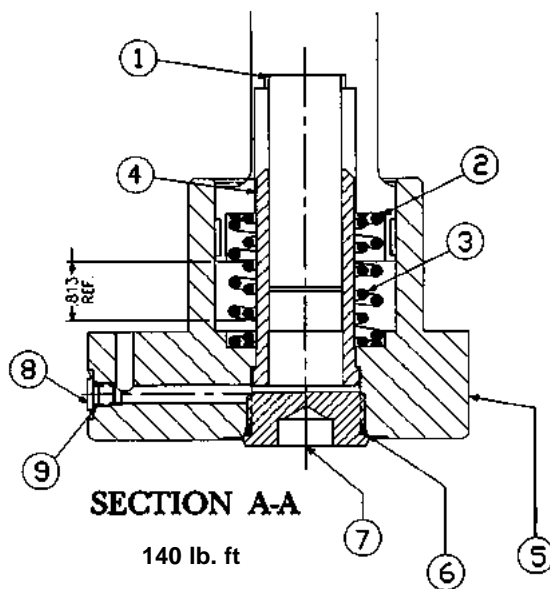

FIGURE 9
Buck-up cap assembly

PARTS LIST FOR FIGURE 9

buck-up cap S22-15653

ITEM	DESCRIPTION	PART NO.	QTY.
1	Piston	324-26448	1
2	Spring	032-92244	1
3	Spring	032-92316	1
4	Sleeve	032-92247	1
5	Control Cap	032-92248	1
6	O-Ring	691-00126	1
7	Plug, SAE-20	449-00614-0	1
8	Plug	488-35046	1
9	O-Ring	691-00902	1

BUCK-UP CAP DISASSEMBLY

1. **See Figure 9.** Set maximum volume stop to full stroke. Remove 4 screws holding cap to pump. Caution! Spring load could cause injury!
2. Remove cap assembly from pump.
3. Remove and examine springs (2), (3) and piston (1). If sleeve (4) is worn, press it out and replace.

ASSEMBLY

1. Install plug (8) + o-ring (9) into cap. Press sleeve (4) into cap to shoulder. Install piston (1), O-ring (6) and plug (7) into cap.
2. Install O-rings on interface between cap and pump control pad. Install spring (2) and spring (3) into control piston. Install cap assembly on pump housing as indicated on page 16 Fig. 5, guiding the control piston into the bore.
3. Torque the assembly bolts to 75 ft-lb (102 Nm). Torque plug (7) to 225 lb-ft (305 Nm).

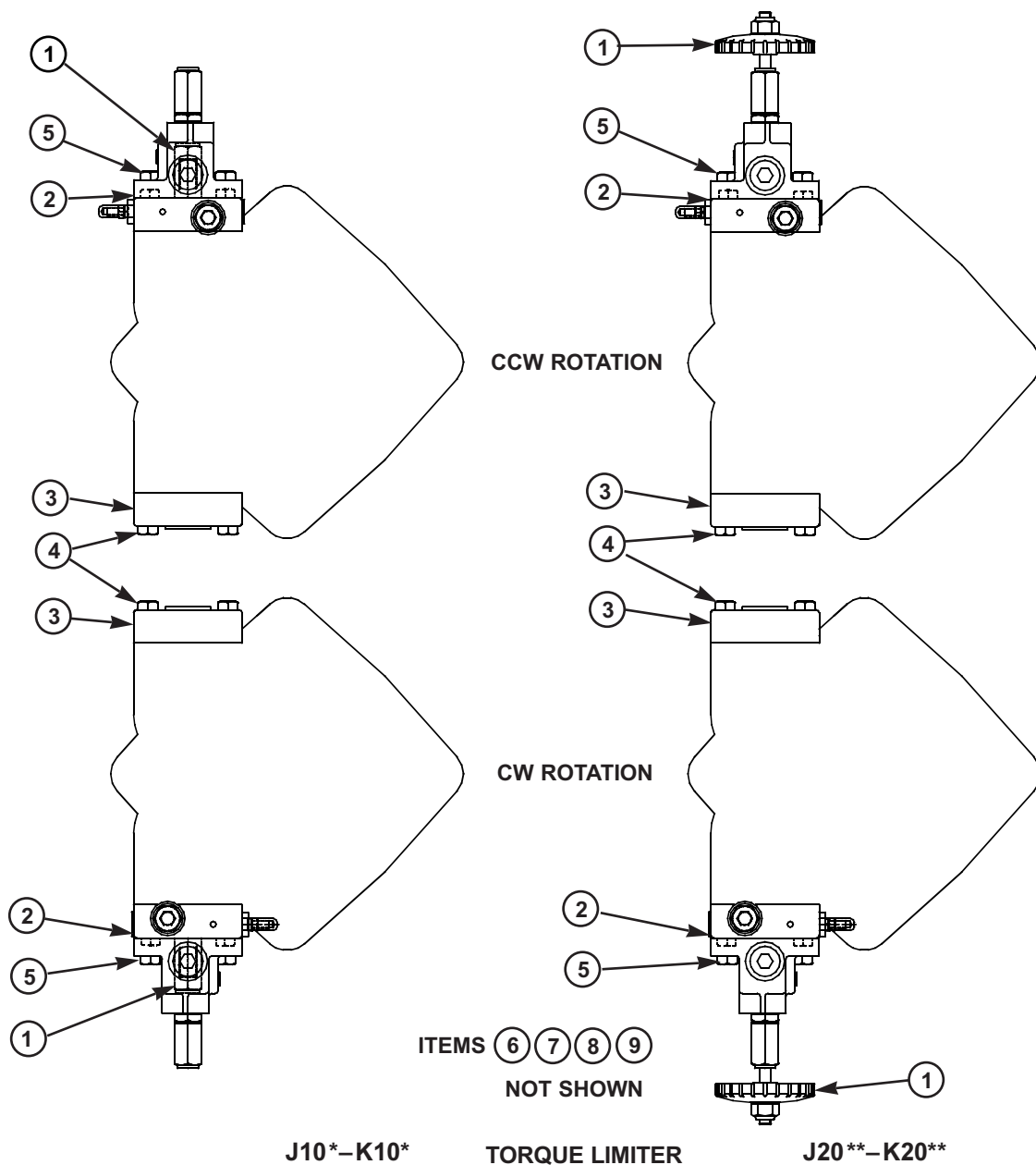

PARTS LIST
torque limiter

ITEM	DESCRIPTION	P09		P140			
		PART NO	PART NO.	J10*	K10*	J20**	K20**
1	Maximum Volume Stop (Fig. 7)	S22-12983	S22-12983	1	1	—	—
	Max Vol. Handwheel (Fig. 8)	S22-12915	S22-12915	—	—	1	1
2	***Low Torque Limiter (Fig. 11)	S22-15732	S22-15733	1	—	-	—
	***High Torque Limiter (Fig. 11)	S22-15313	S22-15314	—	1	—	-
3	Buck Up Cap (Fig. 9)	S22-15653	S22-15653	1	1	1	1
4	Screw-H.H.C., M12 x 60 mm	363-12210	363-12210	6	6	4	4
5	Screw-H.H.C., M12 x 80 mm	363-12225	363-12225	2	2	4	4
6	Control Piston	032-91585	032-91585	1	1	1	1
7	O-Ring, 90 S-1 ARP 013	691-00013	691-00013	2	2	2	2
8	O-Ring, 70 S-1 ARP 152	671-00152	671-00152	2	2	2	2
9	Piston ring	032-92856	032-92856	2	2	2	2

* Also J50, K50

**Also J80, K80

***Include items 1 (Maximum Volume Stop), 4, 5, 7 and 8

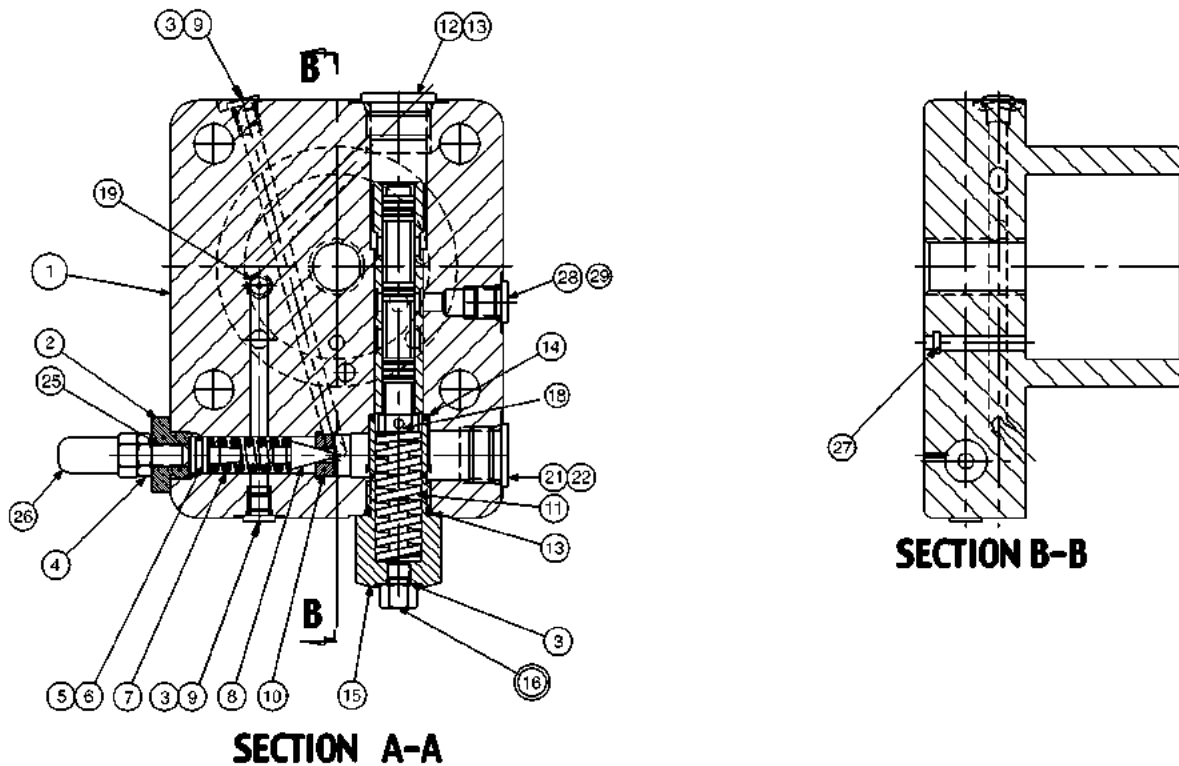

FIGURE 10
Torque limiter cap

PARTS LIST FOR FIGURE 10
P09 torque limiter cap S22-16408
P140 torque limiter cap S22-16409

ITEM	DESCRIPTION	P09		P140	
		PART NO.	QTY	PART NO.	QTY
1	Cap-Sleeve Assembly	S22-12912	1	S22-12922	1
2	Adjusting Plug	032-91814	1	032-91814	1
3	O-ring, 90 S-1 ARP 902	691-00902	3	691-00902	3
4	Nut, 5/16-24	335-13100	1	335-13100	1
5	Seal Piston	031-59367	1	031-59367	1
6	O-Ring, 90 S-1 ARP 012	691-00012	2	691-00012	2
7	Spring	032-91798	1	032-91798	1
8	Cone	036-12288	1	036-12288	1
9	Plug	488-35046	2	488-35046	2
10	Seat	036-11692	1	036-11692	1
11	Spring	032-92874	1	032-92874	1
12	Plug- SAE-10, (1/2 BSPP)	488-35055	1	447-01008	1
13	O-Ring, 90 S-1 ARP 910	691-00910	2	691-00910	1
14	O-Ring, 90 S-1 ARP 017	691-00017	1	691-00017	1
15	Plug	032-92806	1	032-92806	1
16	Plug with stop	S22-16402	1	S22-16402	1
18	Spool	032-92805	1	032-92805	1
19	Orifice	033-25528	1	033-25528	1
21	Plug- SAE-8, 3/8 BSPP	488-35018	1	447-00032	1
22	O-ring, 70 S-1 ARP 908	691-00908	1	-	-
25	Soc. Setscrew 5/16-24 x 1-1/4	312-13180	1	312-13180	1
26	Nut, Acorn 5/16-24	036-33474	1	036-33474	1
27	O-Ring, 70 S-1 ARP 008	671-00008	1	671-00008	1
28	Plug - SAE-4, (1/4 BSPP)	488-35061	1	447-01004	1
29	O-ring 90 S-1 ARP 904	691-00904	1	-	-

TORQUE LIMITER CONTROL

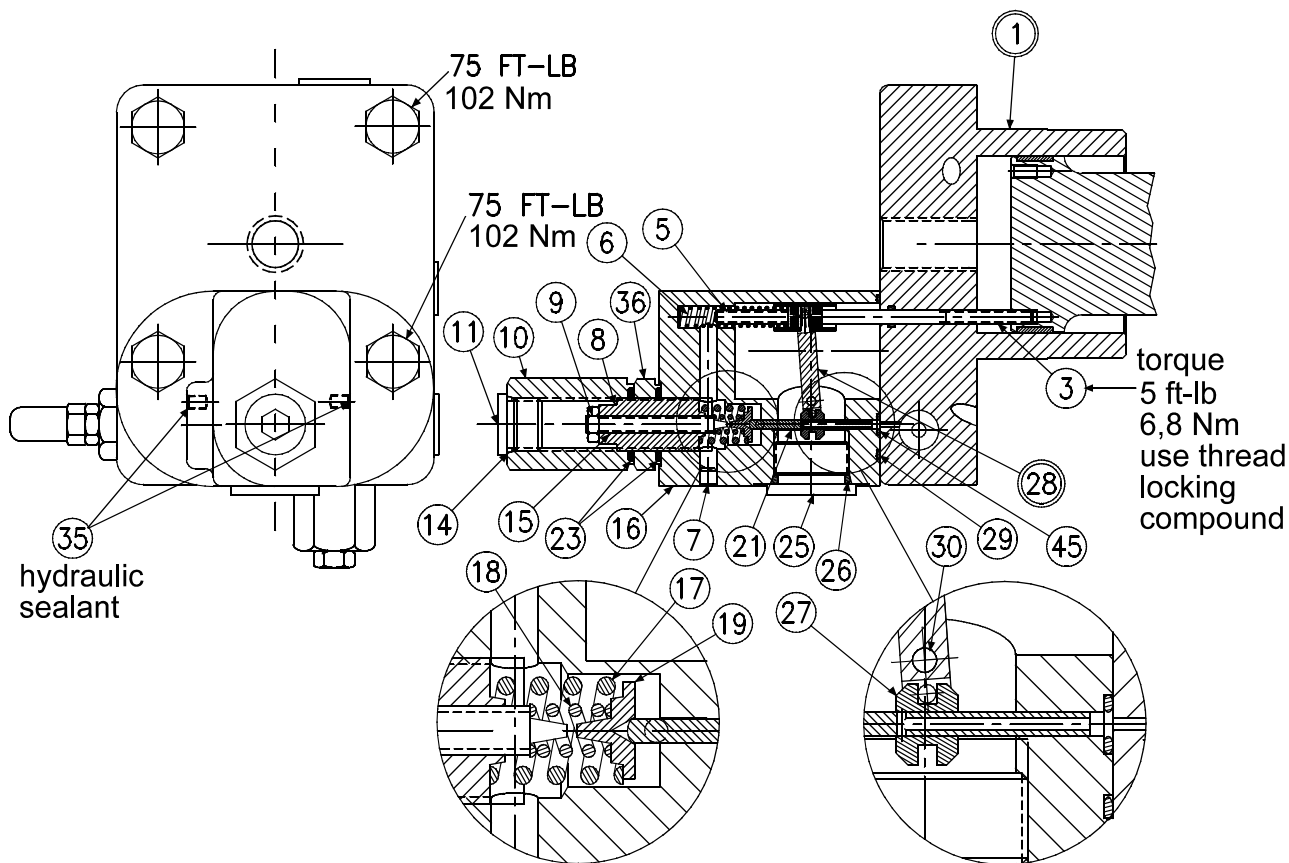

FIGURE 11
Torque Limiter

PARTS LIST FOR FIGURE 11

P09 code J10, J50, S22-15732

P09 code K10, K50, S22-15313

P140 code J10,, J50, S22-15733

P140 code K10, K50, S22-15314

ITEM	DESCRIPTION	P09	P140	QTY.	
		PART NO.	PART NO.	J	K
1	Cap (Figure 10)	S22-16408	S22-16409	1	1
3	Screw	032-91461	032-91461	1	1
5	Clevis pin	321-40000	321-40000	1	1
6	Spring, Compression	032-92100	032-92100	1	1
7	Plug, Avseal	447-00026	447-00026	1	1
8	Screw	032-91445	032-91445	1	1
9	Nut, Hex Jam 1/4-20 UNC	340-00038	340-00038	1	1
10	Hex Nut, 3/4-16 UNF	032-91449	032-91449	1	1
11	Plug, SAE-8	488-35018	488-35018	1	1
14	O-Ring, 90 S-1 ARP 908	691-00908	691-00908	1	1
15	Screw, Primary Adjust	032-91446	032-91446	1	1
16	Body assembly	S22-15396	S22-15396	1	1
17	Outer Spring – J Version	032-91440	032-91440	1	—
	Outer Spring – K Version	032-91440	032-91440	—	1
18	Inner Spring – J Version	032-92240	032-92240	1	—
	Inner Spring – K Version	032-91441	032-91441	—	1
19	Spring Retainer	032-91819	032-91819	1	1
21	Spool	032-91438	032-91438	1	1
23	O-ring, 70 S-1 ARP 118	671-00118	671-00118	2	2
25	Plug, 12 SAE-12	488-35014	488-35014	1	1
26	O-Ring, 90 S-1 ARP 912	691-00912	691-00912	1	1
27	Sleeve	032-91437	032-91437	1	1
28	Arm assembly	S22-15520	S22-15520	1	1
29	O-Ring, 70 S-1 ARP 035	671-00035	671-00035	1	1
30	Dowel Pin, 1/8 Dia. x 1.50 Lg.	324-20824	324-20824	1	1
35	Screw, SHC 10-32 x 1/4	312-09041	312-09041	2	2
36	Nut	032-91645	032-91645	1	1
45	O-Ring, 70 S-1 ARP 010	671-00010	671-00010	1	1

DISASSEMBLY

1. See Figure 13. Remove 2 screws holding torque limiter body (16) to cap assembly (1).
2. Remove all parts from torque limiter body (16) except pin (30) and arm assembly (28). It is not necessary to remove these parts unless broken or worn. Examine parts for wear or damage.
3. Remove screw (3). Examine head for excessive wear, and body for smooth sealing surface with O-ring.
4. Remove maximum stop handwheel assembly or maximum stop screw assembly
5. Remove modulating valve (38) from body (37). Remove body (37) from cap assembly (1) Note plug (40) must be removed to remove special screw (39). Remove cap assembly (1).
1. See Figure 14. Remove plug (15) and attached parts. Remove spring (11) and spool (18).
2. Remove adjusting plug (2) and attached parts. Remove seal piston (5). Note: a 10-24 screw may be used to assist in pulling the piston. Remove spring (7) and cone (8).
3. Do not remove sleeve in body (1). Sleeve is pressed into cap and finished to size. If sleeve or cap is worn, replace the cap-sleeve assembly (1).
4. Examine seat (10) for wear. Do not remove unless damaged.

ASSEMBLY

See page 3 for tightening torque on plugs

1. See Figure 14. Install plug (9) and o-ring (30) and orifice (19) in body.
2. Press seat (10) into bore squarely against shoulder in bore.
3. Install plug (12) and spool (18) into bore as shown. Install spring (11) over end of spool. Install O-ring (31) on stop (16). Lubricate and install into plug (15). Install plug (15) into cap. Install adjustment plug (32), screw (3), nut (4) and cover (17).
4. Install O-ring (6) on seal piston (5).
5. Lubricate O-ring and install cone (8), spring (7) and seal piston into bore in cap (1), being careful that cone enters seat (10). Install remaining parts in body (1)
6. Note proper location for cap on pump (pg.20). Install O-rings on interface between cap and pump control pad
7. Install on pump control pad, guiding the control piston into the bore. Install maximum volume stop or handwheel parts.
8. See Figure 13. Install block (37) on cap (1) with O-rings (4) and (48). Use special screw (39) through the block.
9. Install O-rings (38a and 38b) on valve (38). Observe that backup ring on inside groove is toward the outside, the one on the middle groove is toward the inside, and the one on the outside groove is toward the outside. Lubricate and install valve (38) in block (37), being careful to avoid damaging the O-rings. Torque to 50 lb. ft. (67,8 Nm).
10. For the P200 only, install O-ring (43) on adapter (2). Install adapter in block (37). For the P12 only, install O-ring (43) on plug (42). Install plug (42) in block (37).
11. Apply thread locking compound on threads of screw (3), lubricate the shank, thread through the cap into the control piston, and torque to 5 lb. ft. (6,8 Nm)
12. Measure height from control cap to top of screw. With control piston at full stroke, dimension must be 1.50 +/- .03 in. (38.1 +/- 0.76 mm).
13. Press dowel (30) into body (16), through the link assembly (28), to 1/4 (6.35 mm) below surface. Apply hydraulic sealant to threads of screws (35) and install over dowel (30).
14. While sleeve (27) is engaged into dowel on link (28), slide spool (21) into bore of body (16), and through sleeve (27). Spool (21) must move freely and easily at all positions of the link (28).
15. Assemble remaining parts per drawing. While spring retainer is engaging clevis pin (5) under dowel of link (28), slide the other opening of spring retainer over the top of the screw (3). Attach body assembly (16) to cap (1), and torque mounting screws to 75 lb. ft. (102 Nm).

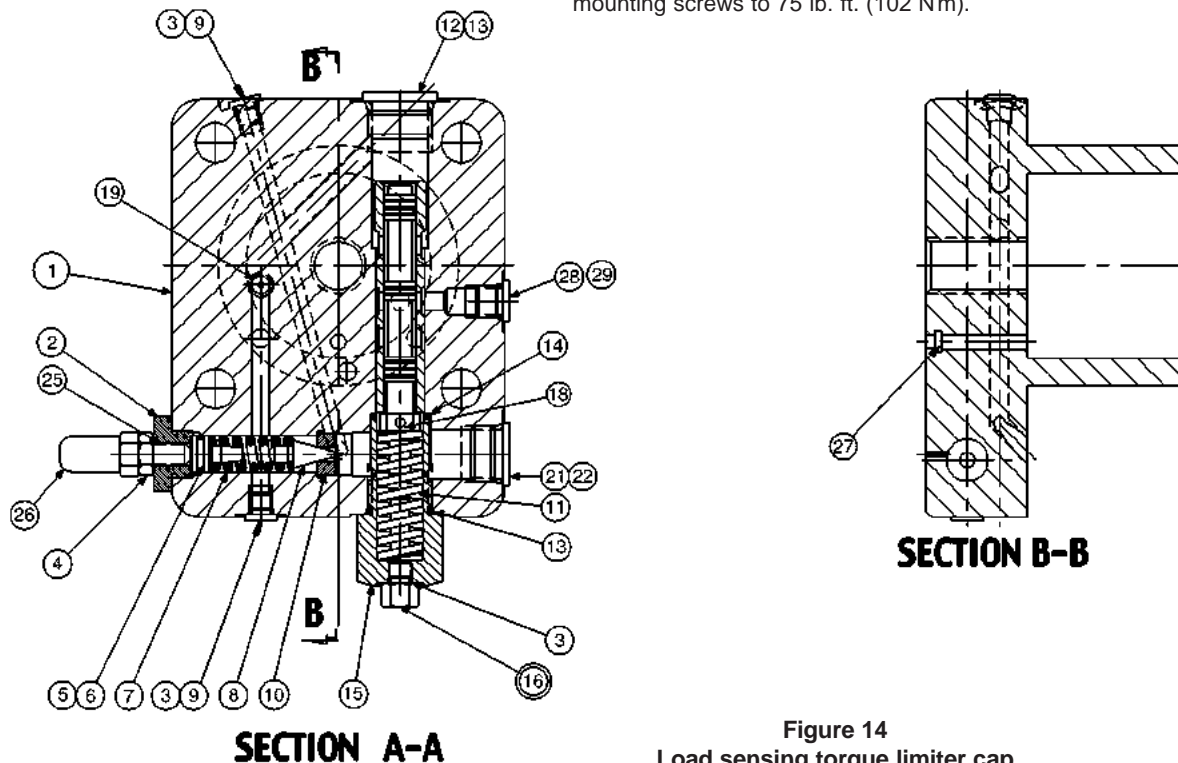
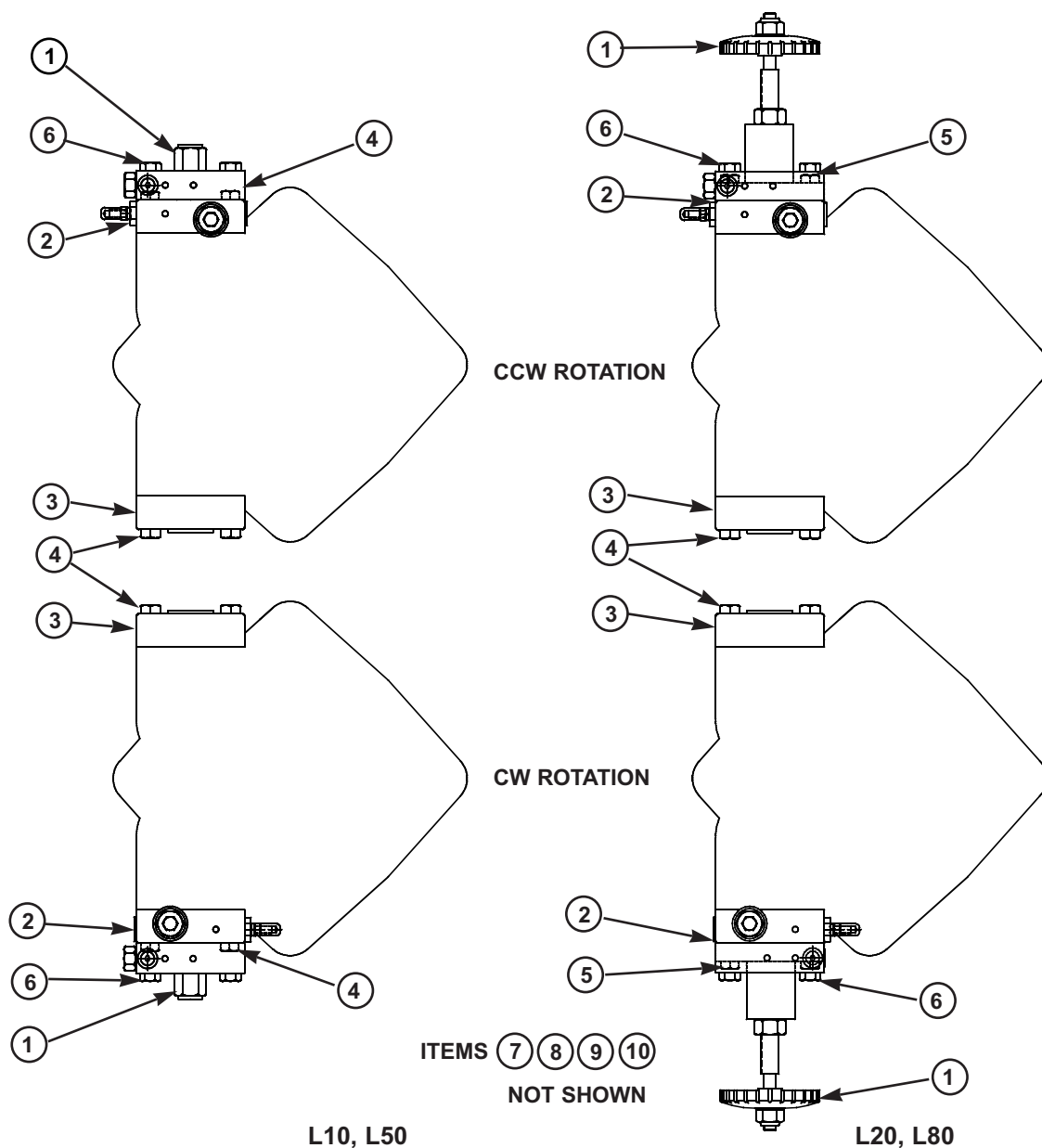

Figure 14
Load sensing torque limiter cap



LOAD SENSING CONTROL

parts list

ITEM	DESCRIPTION	P09	P140	QTY.	
		PART NO.	PART NO.	L10, L50	L20, L80
1	Maximum Volume Stop (Fig. 7)	S22-12983	S22-12983	1	—
	Max Volume Handwheel (Fig. 8)	S22-12915	S22-12915	—	1
2	*Load Sensing Control (Fig. 12)	S22-15536	S22-15537	1	—
3	Buck Up Cap (Fig. 13)	S22-15653	S22-15653	1	1
4	Screw-H.H.C., M12 x 60 mm	363-12210	363-12210	6	4
5	Screw-H.H.C., M12 x 80 mm	363-12225	363-12225	—	2
6	Screw-H.H.C. M12 x 90 mm	363-12240	363-12240	2	2
7	Control Piston	032-91585	032-91585	1	1
8	O-Ring, 90 S-1 ARP 013	691-00013	691-00013	2	2
9	O-Ring, 70 S-1 ARP 152	671-00152	671-00152	2	2
10	Piston Ring	032-92856	032-92856	2	2

*Include items 1 (Maximum Volume Stop), 4, 6, 8 and 9

LOAD SENSING PRESSURE COMPENSATOR CONTROL

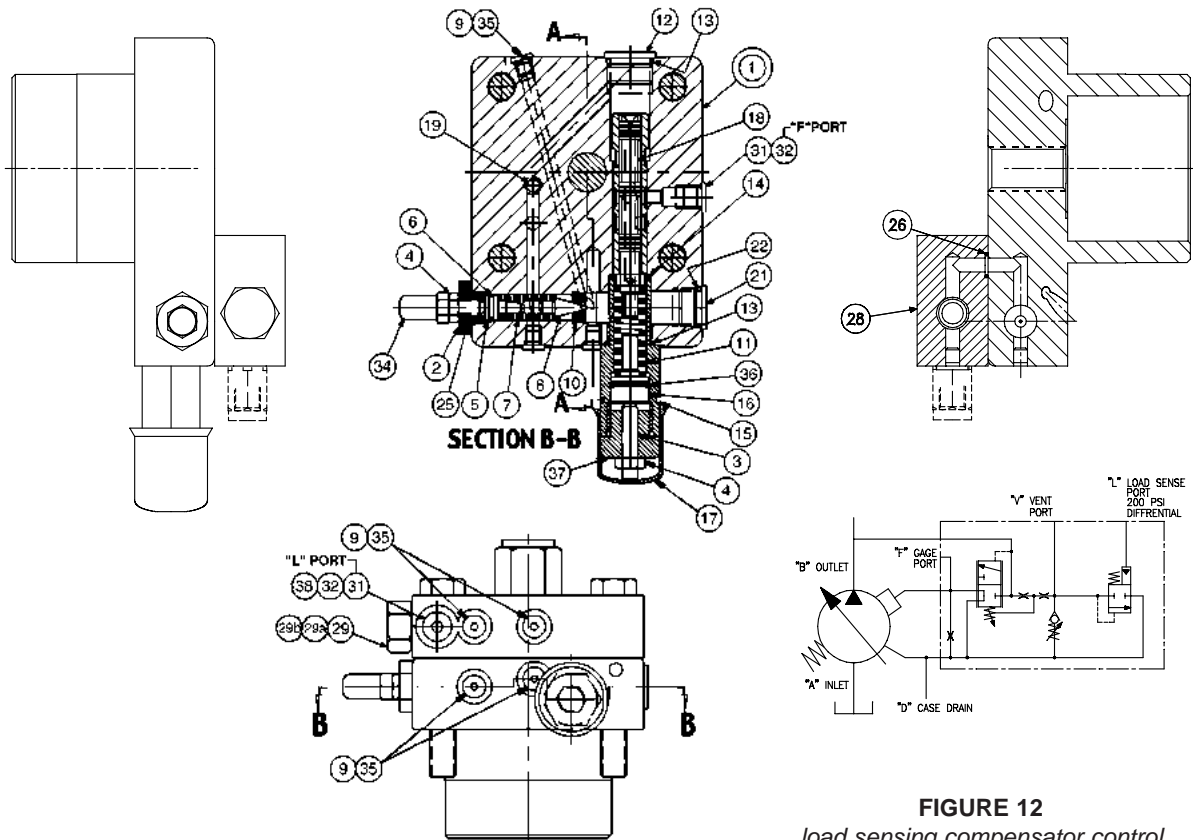

FIGURE 12
load sensing compensator control

PARTS LIST FOR FIG. 12
LOAD SENSING COMPENSATOR
P09 S22-15536
P140 S22-15537

ITEM	DESCRIPTION	P09		P140	
		PART NO.	QTY	PART NO.	QTY
1	Cap-Sleeve Assembly	S22-15143	1	S22-15176	1
2	Adjusting Plug	032-91814	1	032-91814	1
3	Socket Setscrew	312-13200	1	312-13200	1
4	Nut, 5/16-24	335-13100	2	335-13100	2
5	Seal Piston	031-59367	1	031-59367	1
6	O-Ring, 90 S-1 ARP 012	691-00012	2	691-00012	2
7	Spring	032-91798	1	032-91798	1
8	Cone	036-12288	1	036-12288	1
9	Plug	488-35046	5	488-35046	5
10	Seat	036-11692	1	036-11692	1
11	Spring	032-92874	1	033-92874	1
12	Plug, SAE-8, (1/2 BSPP)	488-35055	1	447-01008	1
13	O-Ring, 90 S-1 ARP 910	691-00910	2	691-00910	1
14	O-Ring, 90 S-1 ARP 017	691-00017	1	691-00017	1
15	Plug	032-93488	1	032-93488	1
16	Plug, stop	032-93489	1	032-93489	1
17	Cap	449-00612	1	449-00612	1
18	Spool	032-92805	1	032-92805	1
19	Orifice Plug	033-25528	1	033-25528	1
21	Plug, SAE-8, (3/8 BSPP)	488-35018	1	447-00032	1
22	O-Ring, 90 S-1 ARP 908	691-00908	1	-	-
25	Soc. Setscrew 5/16-24 x 1-1/4	312-13180	1	312-13180	1
26	O-Ring, 70 S-1 ARP 011	671-00011	2	671-00011	2
28	Body-Valve	032-91620	1	032-91620	1
29	"L" Controls	517-00106	1	517-00106	1
	"M" Controls	517-00063	1	517-00063	1
29-A	O-Ring 90 S-1 ARP 017	691-00017	2	691-00017	2
29-B	O-Ring 90 S-1 ARP 015	691-00015	1	691-00015	1
31	Plug, SAE-4, (1/4 BSPP)	488-35061	2	447-01004	2
32	O-Ring, 90 S-1 ARP 904	691-00904	2	691-00904	1
34	Nut, Acorn	036-33474	1	036-33474	1
35	O-ring	691-00902	5	691-00902	5
36	O-ring	691-00016	1	691-00016	1
37	Plug, Adjustment	032-93522	1	032-92522	1
38	Adapter	-	-	032-91507	1

DISASSEMBLY

1. See Figure 12 Back off max. volume screw or handwheel to full displacement. Remove max. volume assembly.
2. Remove bolts holding cap to pump.
3. Remove isolation valve (29) from block (28). Remove plug (15) and attached parts. Remove spring (11) and spool (18).
4. Remove adjusting plug (2) and attached parts. Remove seal piston (5). Note: a 10-24 screw may be used to assist in pulling the piston. Remove spring (7) and cone (8).
5. Do not remove sleeve in body (1). Sleeve is pressed into cap and finished to size. If sleeve or cap is worn, replace the cap-sleeve assembly (1).
6. Examine seat (10) for wear. Do not remove unless damaged.

ASSEMBLY

See page 3 for tightening torque on plugs

1. Install plugs (9) and o-rings (36) and orifice (19) in body.
2. Press seat (10) into bore squarely against shoulder in bore.
3. Install plug (12) and spool (18) into bore as shown. Install spring (11) over end of spool. Install O-ring (36) on stop (16). Lubricate and install into plug (15). Install plug (15) into cap. Install adjustment plug (37), screw (3), nut (4) and cover (17).
4. Install O-ring (6) on seal piston (5).
5. Lubricate O-ring and install cone (8), spring (7) and seal piston into bore in cap (1), being careful that cone enters seat (10). Install remaining parts in body (1).
6. Install O-rings (29-A) and (29-B) on valve (29). Observe that backup ring on inside groove is toward the outside, the one on the middle groove is toward the inside, and the one on the outside groove is toward the outside. Lubricate and install valve (29) in block (28), being careful to avoid damaging the O-rings. Torque to 50 lb. ft. (67,8 Nm).
7. For the P200 only, install O-ring (32) on adapter (38). Install adapter in block (28). Install plug (31) in adapter (38). For the P12 only, install O-ring (32) on plug (31). Install plug (31) in block (28).
8. Note proper location for cap on pump (pg. 20). Install O-rings on interface between cap and pump control pad. Install O-rings (26) in block (28).
9. Install on pump control pad, guiding the control piston into the bore. Install maximum volume stop parts.
10. Torque mounting bolts to 75 lb. ft. (102 Nm).

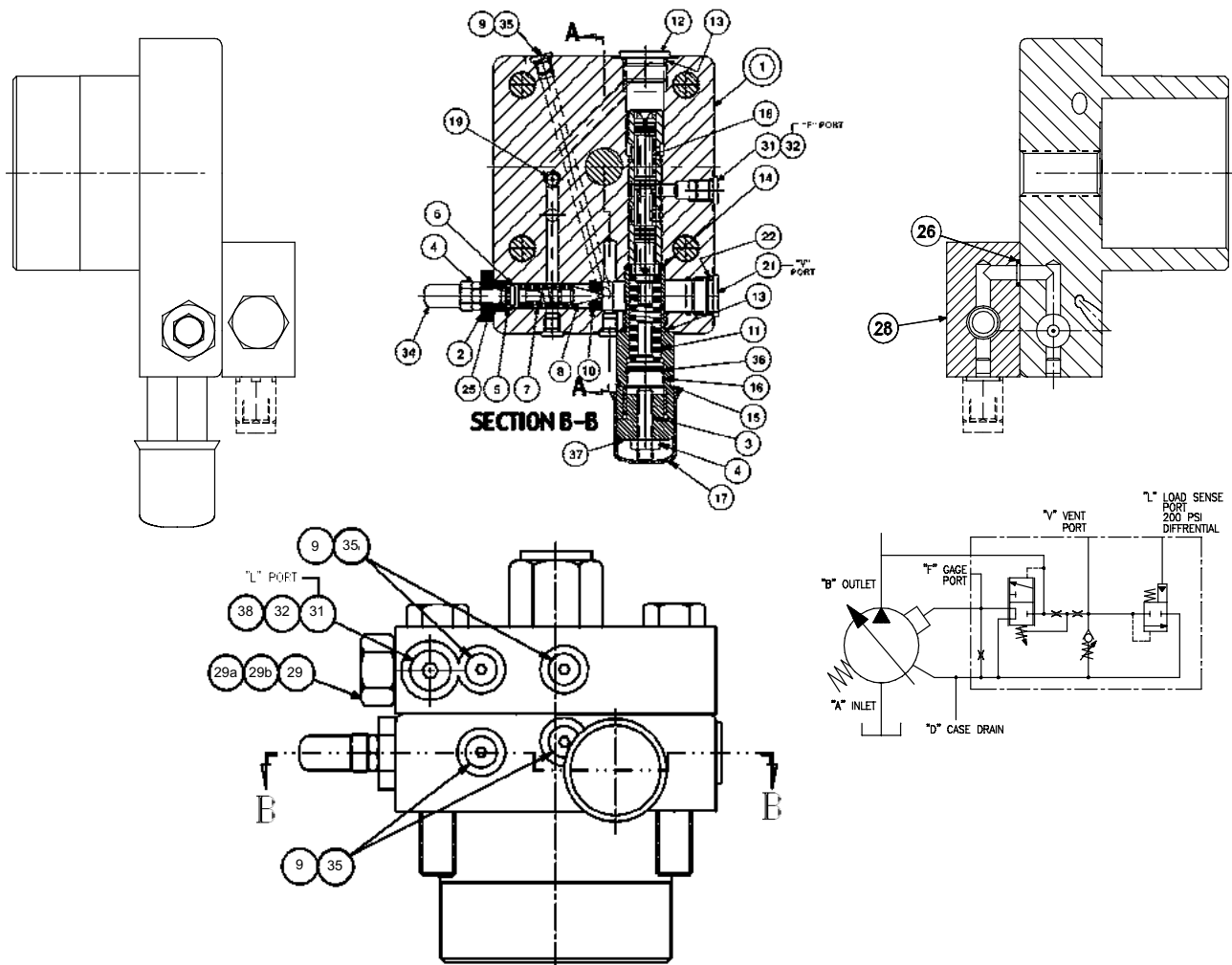

Ref. Figure 12
load sensing compensator control

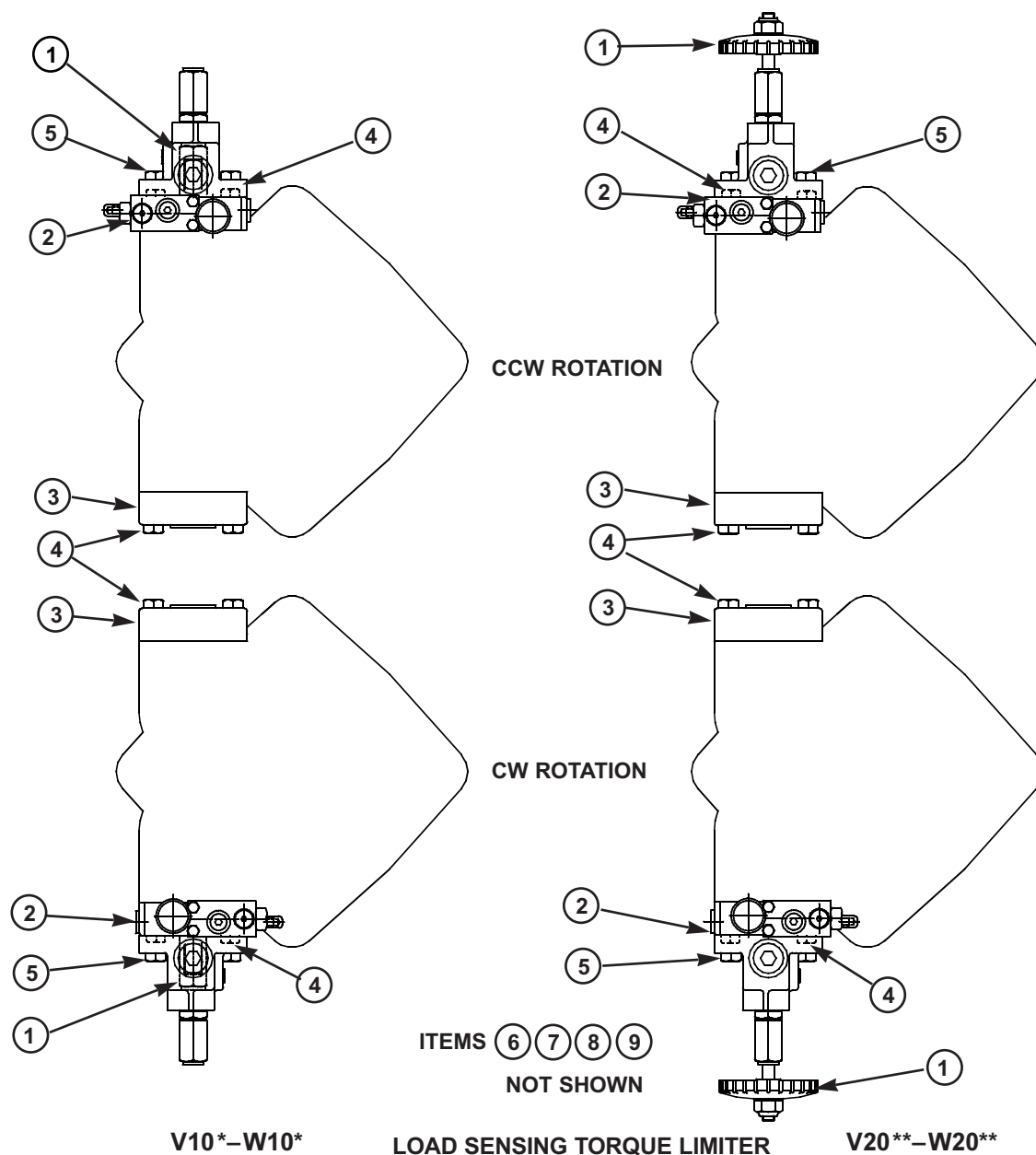

PARTS LIST

load sensing torque limiter

ITEM	DESCRIPTION	P09 PART NO	P140 PART NO.	QUANTITY			
				V10*	W10*	V20**	W20**
1	Maximum Volume Stop (Fig. 7)	S22-12983	S22-12983	1	1	—	—
	Maximum Volume Handwheel (Fig. 8)	S22-12915	S22-12915	—	—	1	1
2	***Low Torque Limiter Load Sensing (Fig. 13)	S22-16193	S22-16194	1	—	—	—
	***High Torque Limiter Load Sensing (Fig. 13)	S22-15790	S22-15802	—	1	—	—
3	Buck Up Cap (Fig. 9)	S22-15653	S22-15653	1	1	1	1
4	Screw-H.H.C., M12 x 60 mm	363-12210	363-12210	6	6	4	4
5	Screw-H.H.C., M12 x 80 mm	363-12225	363-12225	2	2	4	4
6	Control Piston	032-91585	032-91585	1	1	1	1
7	O-Ring, 90 S-1 ARP 013	691-00013	691-00013	2	2	2	2
8	O-Ring, 70 S-1 ARP 152	671-00152	671-00152	2	2	2	2
9	Piston ring	032-92856	032-92856	2	2	2	2

* Also V50, W50

** Also V80, W80

*** Include items 1 (Maximum Volume Stop), 4, 5, 7 and 8

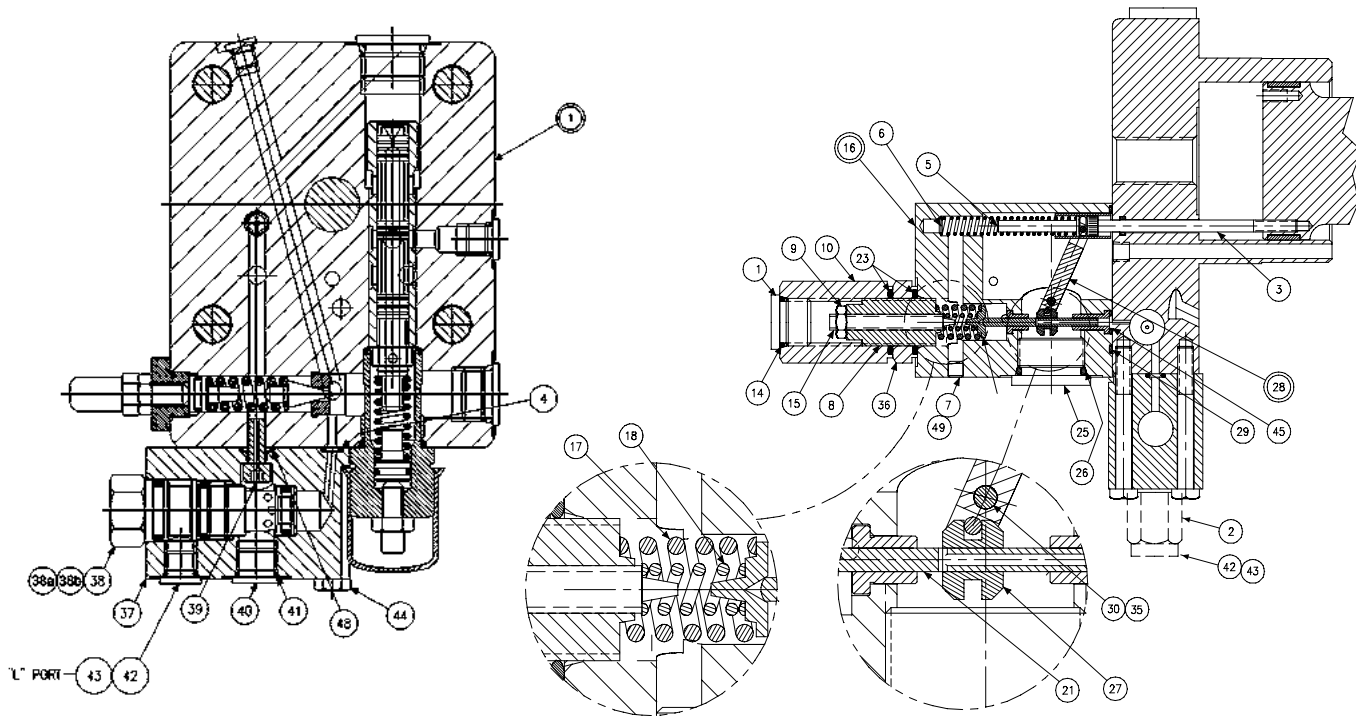

FIGURE 13
Load Sensing Torque Limiter

PARTS LIST FOR FIGURE 13

P09 code V10, V50, S22-16193
 P09 code W10, W50, S22-15790
 P140 code V10, V50, S22-16194
 P140 code W10, W50, S22-15802
 P09 code Y10, Y50, S22-17868
 P09 code Z10, Z50, S22-17870
 P140 code Y10, Y50, S22-17869
 P140 code Z10, Z50, S22-17871

ITEM	DESCRIPTION	P09 PART NO.	P140 ART NO.	QTY	
				V	W
1	Cap (Figure 14)	S22-15791	S22-15411	1	1
2	Adapter	-	032-91507	-	1
3	Screw	032-91461	032-91461	1	1
4	O-ring, 70 S-1 ARP 008	671-00008	671-00008	1	1
5	Clevis pin	321-40000	321-40000	1	1
6	Spring, Compression	032-92100	032-92100	1	1
7	Plug	488-35046	488-35046	1	1
8	Screw	032-91445	032-91445	1	1
9	Nut, Hex Jam 1/4-20 UNC	340-00038	340-00038	1	1
10	Hex Nut, 3/4-16 UNF	032-91449	032-91449	1	1
11	Plug, SAE-8	488-35018	488-35018	1	1
14	O-Ring, 90 S-1 ARP 908	691-00908	691-00908	1	1
15	Screw, Primary Adjust	032-91446	032-91446	1	1
16	Body assembly	S22-15396	S22-15396	1	1
17	Outer Spring V Version	032-91440	032-91440	1	
	Outer Spring W Version	032-91448	032-91448		1
18	Inner Spring V Version	032-92240	032-92240	1	
	Inner Spring W Version	032-91447	032-91447		1
19	Spring Retainer	032-91819	032-91819	1	1
21	Spool	032-91438	032-91438	1	1
23	O-ring, 70 S-1 ARP 118	671-00118	671-00118	2	2
25	Plug, 12 SAE-12	488-35014	488-35014	1	1
26	O-Ring, 90 S-1 ARP 912	691-00912	691-00912	1	1
27	Sleeve	032-91437	032-91437	1	1
28	Arm assembly	S22-15520	S22-15520	1	1
29	O-Ring, 70 S-1 ARP 035	671-00035	671-00035	1	1
30	Dowel Pin	324-20828	324-20828	1	1
35	Screw, SHC 10-32 x 1/4	312-09041	312-09041	2	2
36	Nut	032-91645	032-91645	1	1
37	Body, load sense	032-92359	032-92359	1	1
38	Valve, modulating	See Chart	See Chart	1	1
38a	O-ring, 90 S-1 ARP 017	691-00017	691-00017	2	2
38b	O-ring, 90 S-1 ARP 015	691-00015	691-00015	1	1
39	Screw, special	033-70908	033-70908	1	1
40	Plug, SAE-6	488-35003	488-35003	1	1
41	O-ring, 90 S-1 ARP 906	691-00906	691-00906	1	1
42	Plug, SAE-4, 1/4 BSPP	488-35061	447-01004	1	1
43	O-ring, 90 S-1 ARP 904	691-00904	691-00904	1	1
44	Screw, HHC, 1/4-20x2-1/4	306-40187	306-40187	2	2
45	O-Ring, 70 S-1 ARP 010	671-00010	671-00010	1	1
48	O-Ring, 70 S-1 ARP 012	671-00012	671-00012	1	1
49	O-Ring	691-00902	691-00902	1	1

Item 38
 V & W Controls
 517-00106

 X & Z Controls
 517-00063

DISASSEMBLY

1. See Figure 13. Remove 2 screws holding torque limiter body (16) to cap assembly (1).
2. Remove all parts from torque limiter body (16) except pin (30) and arm assembly (28). It is not necessary to remove these parts unless broken or worn. Examine parts for wear or damage.
3. Remove screw (3). Examine head for excessive wear, and body for smooth sealing surface with O-ring.
4. Remove maximum stop handwheel assembly or maximum stop screw assembly
5. Remove modulating valve (38) from body (37). Remove body (37) from cap assembly (1) Note plug (40) must be removed to remove special screw (39). Remove cap assembly (1).
1. See Figure 14. Remove plug (15) and attached parts. Remove spring (11) and spool (18).
2. Remove adjusting plug (2) and attached parts. Remove seal piston (5). Note: a 10-24 screw may be used to assist in pulling the piston. Remove spring (7) and cone (8).
3. Do not remove sleeve in body (1). Sleeve is pressed into cap and finished to size. If sleeve or cap is worn, replace the cap-sleeve assembly (1).
4. Examine seat (10) for wear. Do not remove unless damaged.

ASSEMBLY

See page 26 for tightening torque on plugs

1. See Figure 14. Install Avseal plug (9) and orifice (19) in body.
2. Press seat (10) into bore squarely against shoulder in bore.
3. Install plug (12) and spool (18) into bore as shown. Install spring (11) over end of spool. Install O-ring (6) on stop (16). Lubricate and install into plug (15). Install plug (15) into cap. Install screw (3), nut (4) and cover (17).
4. Install O-ring (6) on seal piston (5).
5. Lubricate O-ring and install cone (8), spring (7) and seal piston into bore in cap (1), being careful that cone enters seat (10). Install remaining parts in body (1)
6. Note proper location for cap on pump (pg.24). Install O-rings on interface between cap and pump control pad
7. Install on pump control pad, guiding the control piston into the bore. Install maximum volume stop or handwheel parts.
8. See Figure 13. Install block (37) on cap (1) with O-rings (4) and (48). Use special screw (39) through the block.
9. Install O-rings (38a) and (38b) on valve (38). Observe that backup ring on inside groove is toward the outside, the one on the middle groove is toward the inside, and the one on the outside groove is toward the outside. Lubricate and install valve (38) in block (37), being careful to avoid damaging the O-rings. Torque to 50 lb.*ft., 67,8 Nm.
10. For the P140 only, install O-ring (43) on adapter (2). Install adapter in block (37). Install plug (31) in adapter (35). For the P09 only, install O-ring (43) on plug (42). Install plug (42) in block (37).
11. Apply thread locking compound on threads of screw (3), lubricate the shank, thread through the cap into the control piston, and torque to 5 lb.*ft., 6,8 Nm
12. Measure height from control cap to top of screw. With control piston at full stroke, dimension must be 1.50 +/- .03 in., 38,1 +/- 0,76 mm.
13. Press dowel (30) into body (16), through the link assembly (28), to 1/4", 6,35 mm below surface. Apply hydraulic sealant to threads of screws (35) and install over dowel (30).
14. While sleeve (27) is engaged into dowel on link (28), slide spool (21) into bore of body (16), and through sleeve (27). Spool (21) must move freely and easily at all positions of the link (28).
15. Assemble remaining parts per drawing. While spring retainer is engaging clevis pin (5) under dowel of link (28), slide the other opening of spring retainer over the top of the screw (3). Attach body assembly (16) to cap (1) and torque mounting screws to 75 lb.*ft., 102 Nm.

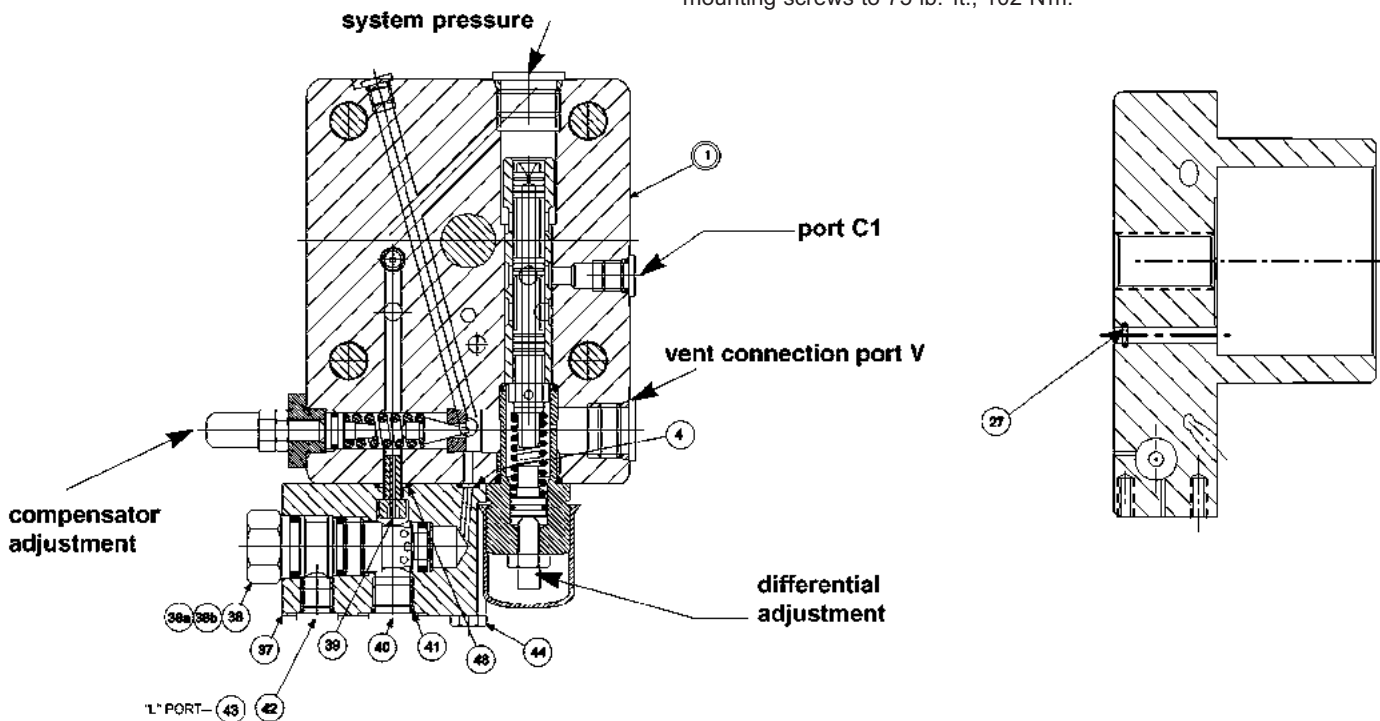
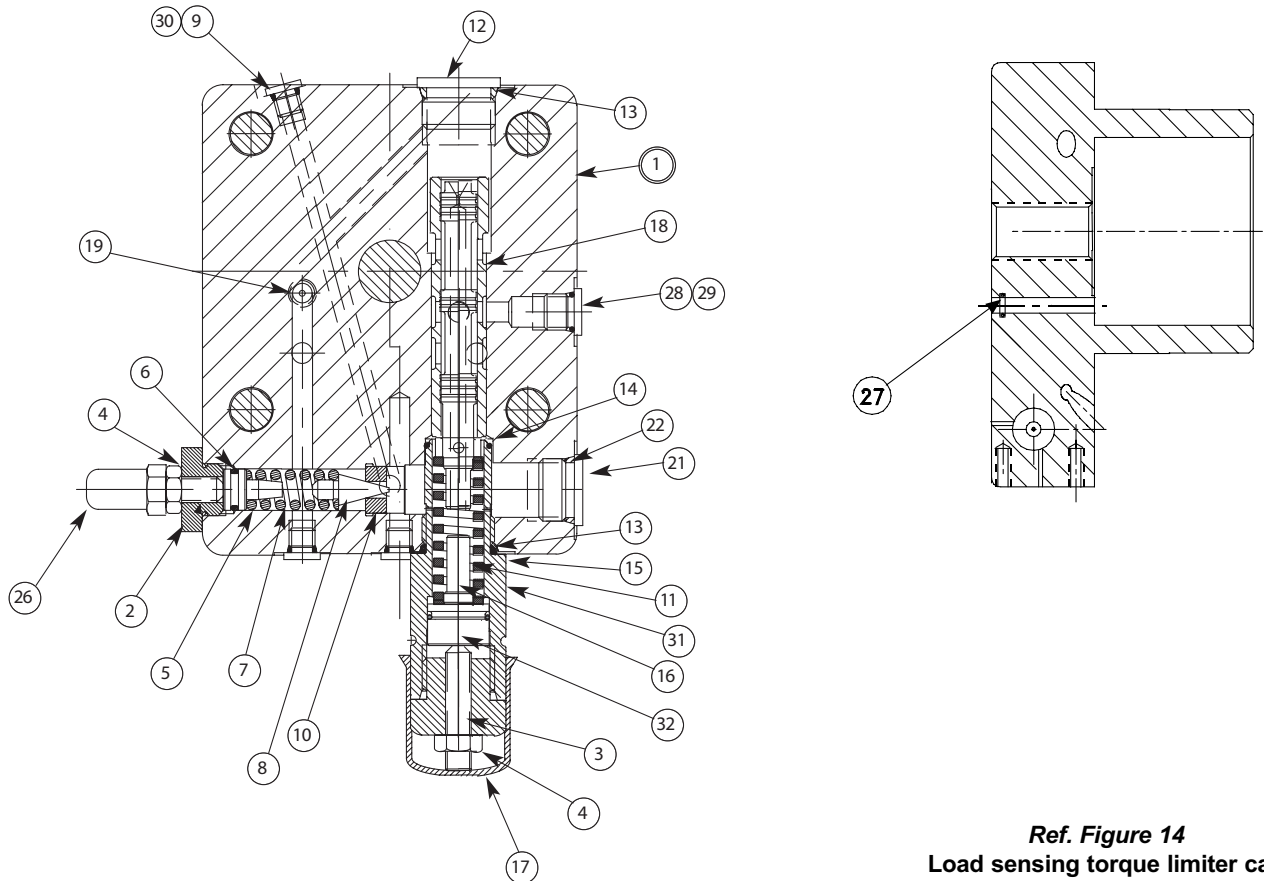

Figure 14
Load sensing torque limiter cap



Ref. Figure 14
Load sensing torque limiter cap

PARTS LIST FOR FIGURE 14
P09 load sensing torque limiter cap
 S22-15791
P140 load sensing torque limiter cap
 S22-15411

ITEM	DESCRIPTION	P09		P140	
		PART NO.	QTY.	PART NO.	QTY.
1	Cap-Sleeve Assembly	S22-15792	1	S22-15410	1
2	Adjusting Plug	032-91814	1	032-91814	1
3	Soc. Setscrew	312-13200	1	312-13200	1
4	Nut, 5/16-24	335-13100	2	335-13100	2
5	Seal Piston	031-59367	1	031-59367	1
6	O-Ring, 90 S-1 ARP 012	691-00012	1	691-00012	1
7	Spring	032-91798	1	032-91798	1
8	Cone	036-12288	1	036-12288	1
9	Plug	488-35046	1	488-35046	1
10	Seat	036-11692	1	036-11692	1
11	Spring	032-92874	1	032-92874	1
12	Plug- SAE-10, 1/2 BSPP	488-35055	1	447-01008	1
13	O-Ring, 90 S-1 ARP 910	691-00910	2	691-00910	1
14	O-Ring, 90 S-1 ARP 017	691-00017	1	691-00017	1
15	Plug	032-93488	1	032-93488	1
16	Stop	032-93489	1	032-93489	1
17	Cap	449-00612	1	449-00612	1
18	Spool	032-92805	1	032-92805	1
19	Orifice	033-25528	1	033-25528	1
21	Plug- SAE-8, 3/8 BSPP	488-35018	1	447-00032	1
22	O-ring, 70 S-1 ARP 908	691-00908	1	-	-
25	Soc. Setscrew 5/16-24 x 1-1/4	312-13180	1	312-13180	1
26	Nut, Acorn 5/16-24	036-33474	1	036-33474	1
27	O-Ring, 70 S-1 ARP 008	671-00008	1	671-00008	1
28	Plug - SAE-4, 1/4 BSPP	488-35061	1	447-01004	1
29	O-ring 90 S-1 ARP 904	691-00904	1	-	-
30	O-ring 90 S-1 ARP 902	691-00902	1	691-00902	1
31	O-ring	691-00016	1	691-00016	1
32	Plug-Adjustment	032-93522	1	032-93522	1

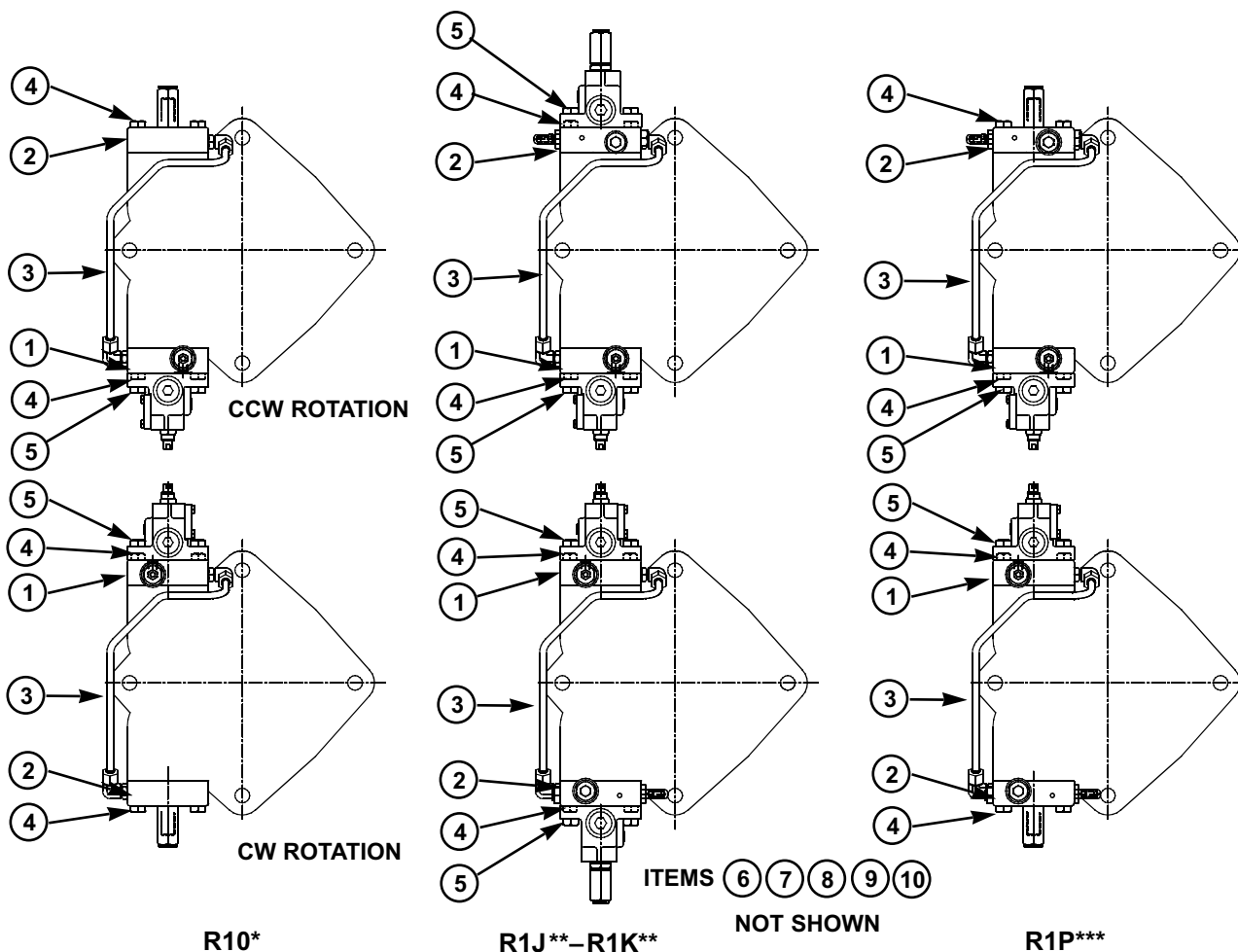

PARTS LIST

rotary servo

ITEM	DESCRIPTION	P09	P140	QUANTITY			
		PART NO.	PART NO.	R10*	R1J**	R1K**	R1P***
1	#Rotary Servo (Fig. 15)	S22-16005	S22-16006	1	1	1	1
2	#Control Cap (Fig.26)	S22-15256	S22-15272	1	—	—	—
	#Low Torque Override (Fig. 29)	S22-16183	S22-16184	—	1	—	—
	#High Torque Override (Fig. 29)	S22-16009	S22-16010	—	—	1	—
	#Compensator Override (Fig. 27)	S22-16007	S22-16008	—	—	—	1
3	Tube Assembly (Fig. 24, 25)	S22-16084	S22-16086	1	1	1	1
4	Screw-H.H.C., M12 x 60 mm	363-12210	363-12210	6	4	4	6
5	Screw-H.H.C., M12 x 80 mm	363-12225	363-12225	2	4	4	2
6	Control Piston	032-91881	032-91881	1	1	1	1
7	O-Ring, 90 S-1 ARP 013	691-00013	691-00013	2	2	2	2
8	O-Ring, 70 S-1 ARP 152	671-00152	671-00152	2	2	2	2
9	Piston Ring	032-92856	032-92856	1	1	1	1
10	Piston Ring	032-92855	032-92855	1	1	1	1

*Also R50

**Also R5J, R5K

***Also R5P

#Includes items 4, 5, 7 and 8

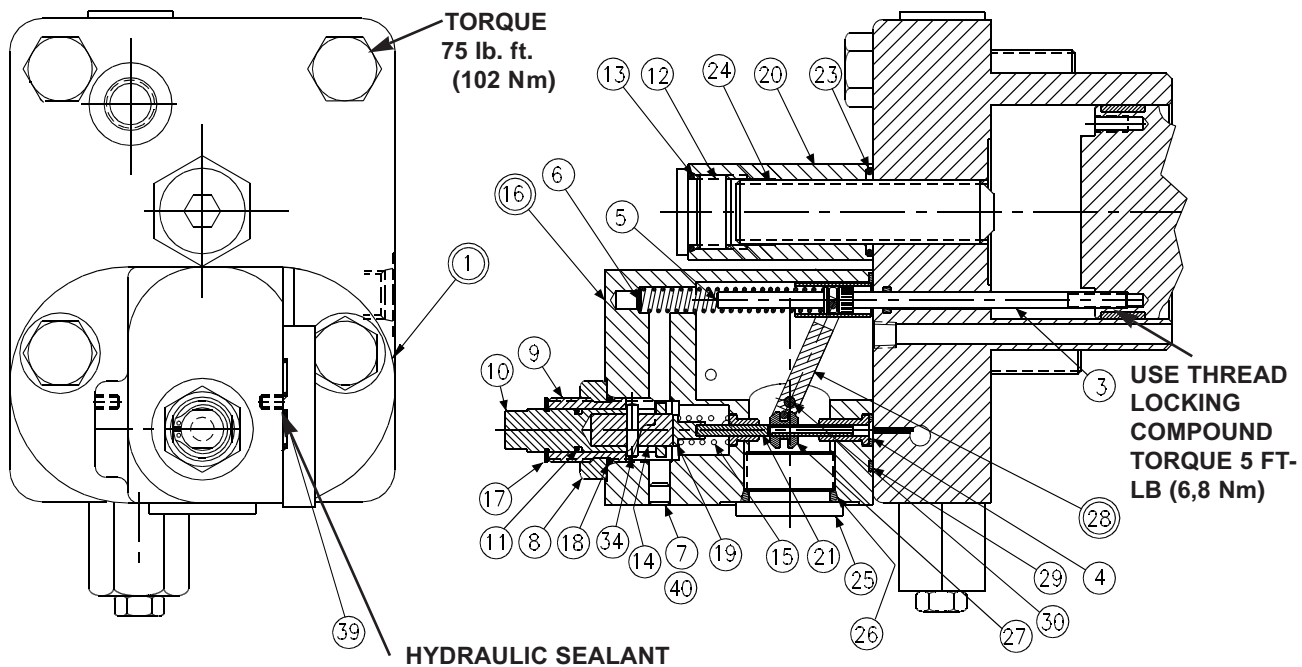

FIGURE 15
rotary servo

**PARTS LIST FOR FIGURE 15
ROTARY SERVO**

P09 S22-16005
P140 S22-16006

ITEM	DESCRIPTION	P09		P140	
		PART NO.	QTY.	PART NO.	QTY.
1	Cap (Figure 16)	S22-16449	1	S22-16451	1
3	Screw	032-91461	1	032-91461	1
4	O-Ring, 70 S-1 ARP 010	671-00010	1	671-00010	1
5	Pin, Clevis	321-40000	1	321-40000	1
6	Spring, Compression	032-92100	1	032-92100	1
7	Plug	488-35046	1	488-35046	1
8	Locknut	492-15364	1	492-15364	1
9	Cam	032-91515	1	032-91515	1
10	Shaft	032-91514	1	032-91514	1
11	O-Ring, 90 S-1 ARP 012	691-00012	1	691-00012	1
12	Plug, 10HP5N-S	488-35055	1	488-35055	1
13	O-Ring, 90 S-1 ARP 910	691-00910	1	691-00910	1
14	Slide Pin	032-91513	1	032-91513	1
15	Spring	225-92105	1	225-92105	1
16	Body	S22-15396	1	S22-15396	1
17	Retaining Ring	356-31050	1	356-31050	1
18	O-Ring, 90 S-1 ARP 908	691-00908	1	691-00908	1
19	Spring Retainer	032-91516	1	032-91516	1
20	Nut, 3/4-10	031-91049	1	031-91049	1
21	Spool	032-91438	1	032-91438	1
23	O-Ring, 70 S-1 ARP 118	671-00118	1	671-00118	1
24	Soc. Setscrew, 3/4-10 x 3	311-45049	1	311-45049	1
25	Plug, 12 HP5N-S	488-35014	1	488-35014	1
26	O-Ring, 90 S-1 ARP 912	691-00912	1	691-00912	1
27	Sleeve	032-91437	1	032-91437	1
28	Arm assembly	S22-15520	1	S22-15520	1
29	O-Ring, 70 S-1 ARP 035	671-00035	1	671-00035	1
30	Dowel Pin, 1/8 Dia x 1.5 Lg.	324-20828	1	324-20828	1
34	Dowel Pin, 1/8 x 5/8	324-20810	1	324-20810	1
39	Screw, SHC 10-32 x 1/4	312-09041	2	312-09041	2
40	O-ring	691-00902	1	691-00902	1

DISASSEMBLY

1. See Figure 15. Remove 2 screws holding body (16) to cap assembly (1).
2. Remove all parts from body (16) except pin (30) and arm assembly (28). It is not necessary to remove these parts unless broken or worn. Examine parts for wear or damage.
3. Remove screw (3). Examine head for excessive wear, and body for smooth sealing surface with O-ring.
4. See Figure 16. Remove tube lines to cap assembly.
5. Remove screws holding cap assembly to pump body.
6. Remove cap assembly (1). Remove plug (3) with attached parts. Remove spring (8) and spool (4).
7. Do not remove sleeve in body (1). Sleeve is pressed into cap and finished to size. If sleeve or cap is worn, replace the cap-sleeve assembly (1).

ASSEMBLY

See page 3 for tightening torque on plugs

1. See Figure 16. Install plug (6) and O-ring (13) in cap.
2. Install spool (4) into bore as shown. Install spring (8) over end of spool.
3. Install plug with stop (14) and O-ring (13) into plug (3).
4. Install O-rings (7) and (16) on plug (3). Install plugs (3) and (9) into body (1).
5. Install orifices (20) and (21) and plugs (10). Torque plugs. Install O-ring (5) in cap.
6. Note proper location for control on pump (pg. 20). Install O-rings on interface between cap and pump control pad. Install cap on pump control pad, guiding the control piston into the bore.
7. Torque two assembly bolts to 75 lb. ft. (102 N m).
8. See Figure 15. Apply thread locking compound on threads of screw (3), lubricate the shank, thread through the cap into the control piston, and torque to 5 lb. ft. (6,78 N m).
9. Install minimum stop screw (24) and turn clockwise to stroke pump to full stroke. Measure height from control cap to top of screw (3). With control piston at full stroke, dimension must be .67 +/- .03 in. (16,9 +/- 0,76 mm). Back out minimum stop screw (24) till there is no contact with control piston.
10. Press dowel (30) into body (16), through the link (28), to 1/4 in. (6.35 mm) below surface. Apply hydraulic sealant to threads of screws (39) and install over dowel (30).
11. Press spool (21) into retainer (19). Caution: do not use excessive force.
12. While sleeve (27) is engaged into dowel on link (28), slide above spool assembly with spring (15) into bore of body (16), and through sleeve (27). Spool (21) must move freely and easily at all positions of the link (28).
13. Press dowel (34) through slide pin (14), while inside shaft (10). Dowel (34) must evenly extend from both sides of slide pin (14).
14. Assemble all other components into body (16) per Figure 18. Torque plug (12)
15. While spring retainer is engaging clevis pin (5) under dowel of link (28), slide the other opening of spring retainer over the top of the screw (3). Attach body assembly (16) to cap (1) with two screws, and torque to 75 lb. ft. (103 N m).
16. Install tubing assembly (Figure 24, 25).

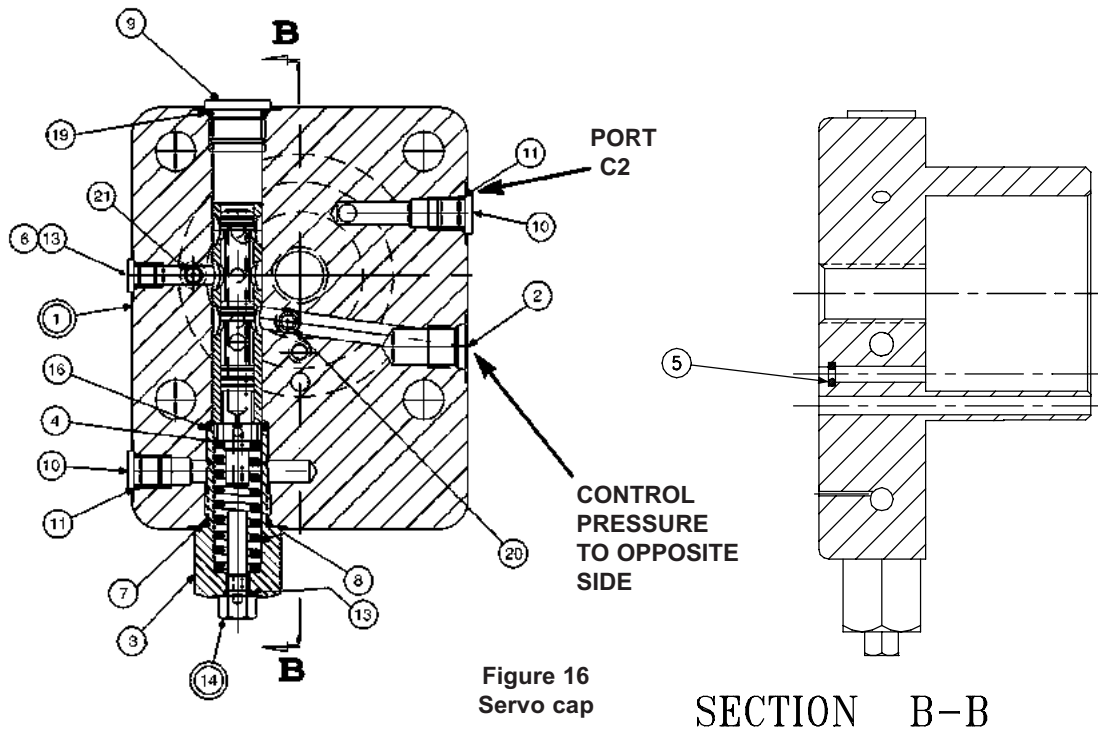
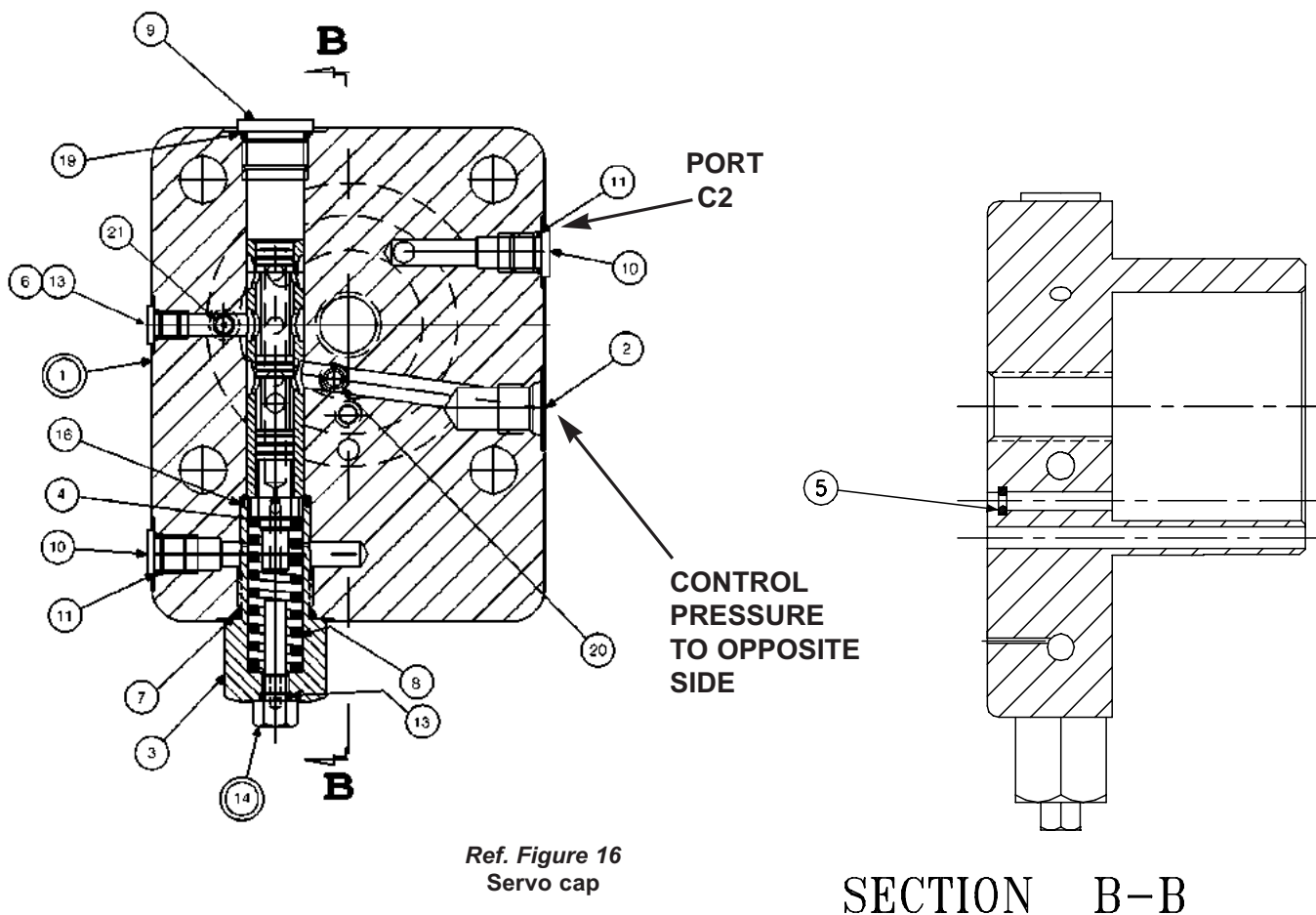

Figure 16
Servo cap

SECTION B-B



Ref. Figure 16
Servo cap

SECTION B-B

PARTS LIST FOR FIGURE 16

P09 servo cap S22-16449

P140 servo cap S22-16451

ITEM	DESCRIPTION	P09		P140	
		PART NO.	QTY.	PART NO.	QTY.
1	Cap/Sleeve	S22-15914	1	S22-15915	1
2	Plug	449-00015	1	449-00599	1
3	Plug	032-92806	1	032-92806	1
4	Spool	032-92911	1	032-92911	1
5	O-Ring, 70 S-1 ARP 008	671-00008	1	671-00008	1
6	Plug, with stop	488-35046	1	488-35046	1
7	O-Ring, 90 S-1 ARP 910	691-00910	1	691-00910	1
8	Spring	032-92874	1	032-92874	1
9	Plug, SAE-8, 1/2 BSPP	488-35018	1	447-01008	1
10	Plug, SAE-4, 1/4 BSPP	488-35061	2	447-01004	2
11	O-ring, 90 S-1 ARP 904	691-00904	2	-	2
13	O-Ring, 90 S-1 ARP 902	691-00902	2	691-00902	2
14	Plug, with stop	S22-16402	1	S22-16402	1
16	O-Ring, 90 S-1 ARP 017	691-00017	1	691-00017	1
19	O-ring, 90 S-1 ARP 908	691-00908	1	-	-
20	Orifice	033-25528	1	033-25528	1
21	Orifice .078	032-93071	1	032-93071	1

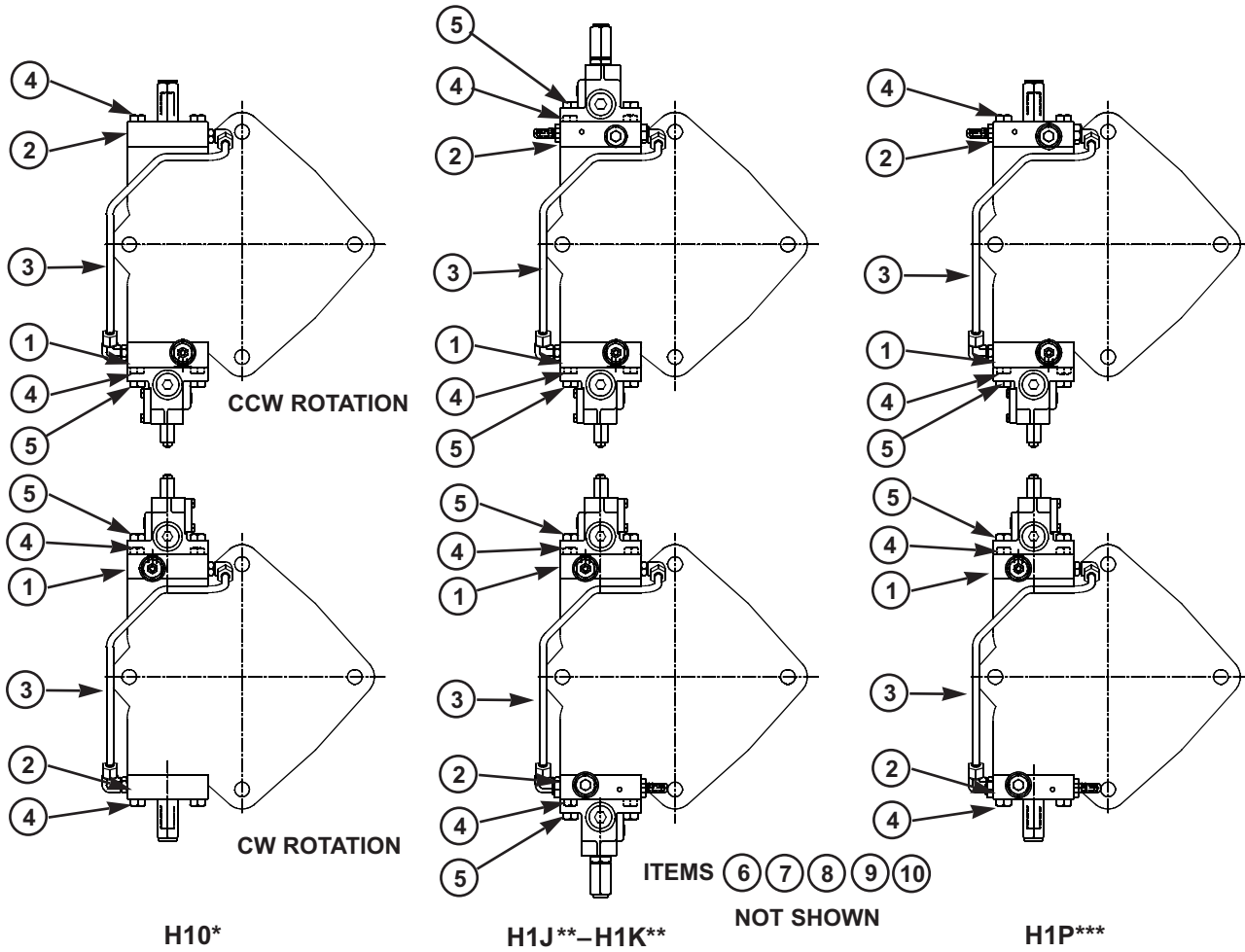

PARTS LIST
hydraulic stroker

ITEM	DESCRIPTION	P09 PART NO.	P140 PART NO.	QUANTITY			
				H10*	H1J**	H1K**	H1P***
1	#Hydraulic Stroker (Fig. 17)	S22-16003	S22-16004	1	1	1	1
2	#Control Cap (Fig. 26)	S22-15256	S22-15272	1	—	—	—
	#Low Torque Override (Fig. 29)	S22-16183	S22-16184	—	1	—	—
	#High Torque Override (Fig. 29)	S22-16009	S22-16010	—	—	1	—
	#Compensator Override (Fig. 27)	S22-16007	S22-16008	—	—	—	1
3	Tube Assembly Fig. 24, 25)	S22-16084	S22-16086	1	1	1	1
4	Screw-H.H.C., M12 x 60 mm	363-12210	363-12210	6	4	4	6
5	Screw-H.H.C., M12 x 80 mm	363-12225	363-12225	2	4	4	2
6	Control Piston	032-91881	032-91881	1	1	1	1
7	O-Ring, 90 S-1 ARP 013	691-00013	691-00013	2	2	2	2
8	O-Ring, 70 S-1 ARP 152	671-00152	671-00152	2	2	2	2
9	Piston Ring	032-92856	032-92856	1	1	1	1
10	Piston Ring	032-92855	032-92855	1	1	1	1

*Also H50

**Also H5J, H5K

***Also H5P

#Includes items 4, 5, 7 and 8

HYDRAULIC STROKER CONTROL

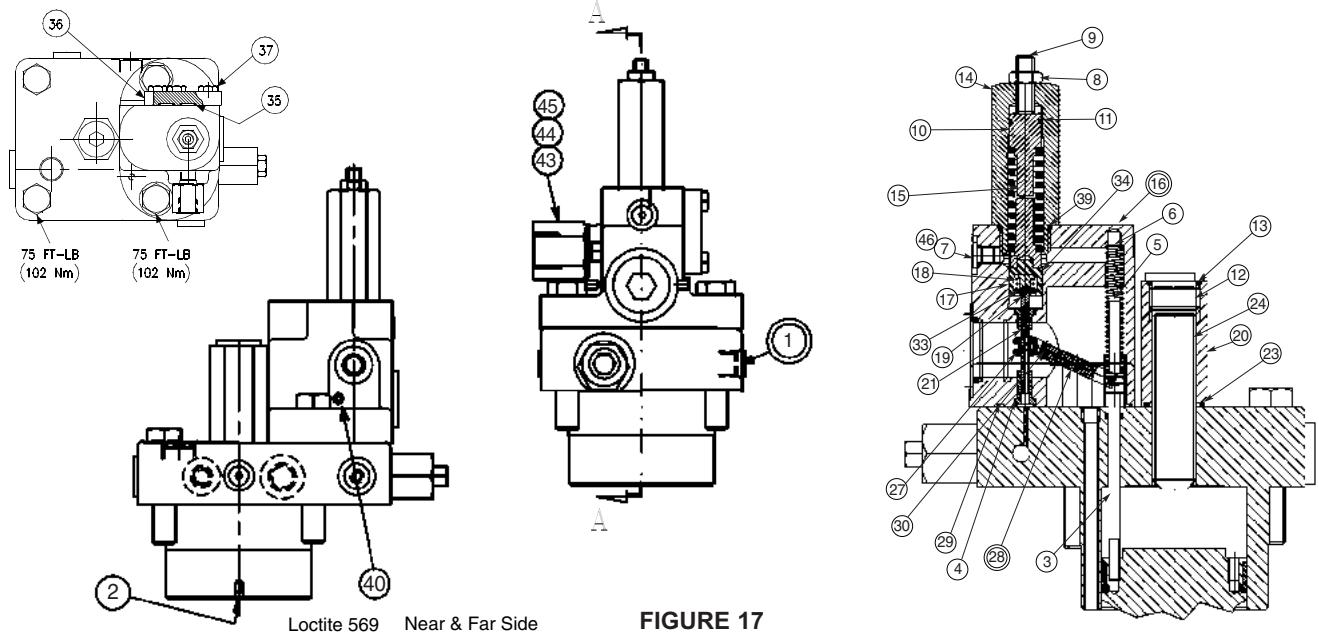

FIGURE 17
hydraulic stroker

PARTS LIST FOR FIG. 17

P09 hydraulic stroker S22-16003

P140 hydraulic stroker S22-16004

ITEM	DESCRIPTION	P09		P140	
		PART NO.	QTY.	PART NO.	QTY.
1	Cap (Figure 16)	S22-16449	1	S22-16451	1
2	Orifice Screw (.078)	032-93071	1	032-93071	1
3	Screw	032-91461	1	032-91461	1
4	O-Ring, 70 S-1 ARP 010	671-00010	1	671-00010	1
5	Clevis pin	321-40000	1	321-40000	1
6	Spring, Compression	032-92100	1	032-92100	1
7	Plug	488-35046	1	488-35046	1
8	Nut, 5/16-24	335-13100	1	335-13100	1
9	Soc. Setscrew, 5/16-24 x 1-1/4	312-13160	1	312-13160	1
10	Retainer	032-92891	1	032-92891	1
11	O-Ring, 90 S-1 ARP 012	691-00013	1	691-00013	1
12	Plug, 10HP5N-S	488-35055	1	488-35055	1
13	O-Ring, 90 S-1 ARP 910	691-00910	1	691-00910	1
14	Spring Housing	032-93473	1	032-93473	1
15	Spring	032-93494	1	032-93494	1
16	Body	S22-17293	1	S22-17293	1
17	Spool	032-91512	1	032-91512	1
18	Spring	225-92109	1	225-92109	1
19	Spring Retainer	032-91516	1	032-91516	1
20	Nut, 3/4-10	031-91049	1	031-91049	1
21	Spool	032-91438	1	032-91438	1
23	O-Ring, 70 S-1 ARP 118	671-00118	1	671-00118	1
24	Soc. Setscrew, 3/4-10 x 3	311-45049	1	311-45049	1
25	Plug, SAE-12	032-93490	1	032-93490	1
26	O-Ring, 90 S-1 ARP 912	691-00912	1	691-00912	1
27	Sleeve	032-91437	1	032-91437	1
28	Arm assembly	S22-15520	1	S22-15520	1
29	O-Ring, 70 S-1 ARP 035	671-00035	1	671-00035	1
30	Dowel Pin, 1/8 Dia x 1.5 Lg.	324-20828	1	324-20828	1
33	Retaining. Ring	356-30037	1	356-30037	1
34	Washer	032-91517	1	032-91517	1
35	O-Ring, 70 S-1 ARP 011	671-00011	2	671-00011	2
36	Plate	032-91510	1	032-91510	1
37	Screw, HHC, 1/4-20 x 3/4	306-40142	3	306-40142	3
39	O-Ring, 90 S-1 ARP 908	691-00910	1	691-00910	1
40	Screw, SHC 10-32 x 1/4	312-09041	2	312-09041	2
41	Guide	032-93475	2	032-93475	2
43	Fitting	-	-	032-91507	1
44	Seal	-	-	449-00603	1
45	O-ring, 90 S-1 ARP 904	-	-	691-00904	1
46	O-ring	691-00902	1	691-00902	1

DISASSEMBLY

1. **See Figure 18.** Remove 3 screws (37) holding block (36) to body (16).
2. Remove 2 screws holding body (16) to cap assembly (1).
3. Remove all parts from body (16) except pin (30) and arm assembly (28). It is not necessary to remove these parts unless broken or worn. Examine parts for wear or damage.
4. Remove screw (3). Examine head for excessive wear, and body for smooth sealing surface with O-ring.
5. **See Figure 16.** Remove tube lines to cap assembly.
6. Remove screws holding cap assembly to pump body.
7. Remove cap assembly (1). Remove plug (3) with attached parts. Remove spring (8) and spool (4).
8. Do not remove sleeve in body (1). Sleeve is pressed into cap and finished to size. If sleeve or cap is worn, replace the cap-sleeve assembly (1).

ASSEMBLY

See page 3 for tightening torque on plugs

1. **See Figure 16.** Install plug (6) and o-ring (13) in cap.
2. Install spool (4) into bore as shown. Install spring (8) over end of spool.
3. Install plug with stop (14) and O-ring (13) into plug (3).
4. Install O-rings (7) and (16) on plug (3). Install plugs (3) and (9) into body (1).
5. Install orifices (20) and (21) and plugs (10). Torque plugs. Install O-ring (5) in cap.
6. Note proper location for control on pump (pg. 20). Install O-rings on interface between cap and pump control pad. Install cap on pump control pad, guiding the control piston into the bore.
7. Torque two assembly bolts to 75 lb. ft. (102 N m).
8. **See Figure 18.** Apply thread locking compound on threads of screw (3), lubricate the shank, thread through the cap into the control piston, and torque to 5 lb. ft. (6.78 N m).
9. Install minimum stop screw (24) and turn clockwise to stroke pump to full volume. Measure height from control cap to top of screw (3). With control piston at full stroke, dimension must be .67 +/- .03 in. (16,9 +/- 0.76 mm). Back out minimum stop screw (24) till there is no contact with control piston.
10. Press dowel (30) into body (16), through the link (28), to 1/4" (6.35 mm) below surface, apply hydraulic sealant to threads of screws (46) and install over dowel (30).
11. Press spool (21) into retainer (19). Caution: do not use excessive force. Place spool/retainer assembly into spool (17) with spring (18) and washer (34). Secure with retaining ring (33).
12. While sleeve (27) is engaged into dowel on link (28), slide above spool assembly into bore of body (16), and through sleeve (27). Spool (21) must move freely and easily at all positions of the link (28).
13. Install proportional valve (41) in block. Torque to 20 ft. lbs. (27 N m).
14. Install coil (42) on proportional valve. Torque to 20-25 in. lbs. (2.2-2.8 N m) max.
15. Assemble all other components into body (16) per above drawing. Torque the plug (12).
16. While spring retainer is engaging clevis pin (5) under dowel of link (28), slide the other opening of spring retainer over the top of the screw (3). Attach body assembly (16) to cap (1) with two screws, and torque to 75 lb. ft. (102 N m).
17. Install tubing assembly (Figure 24, 25).

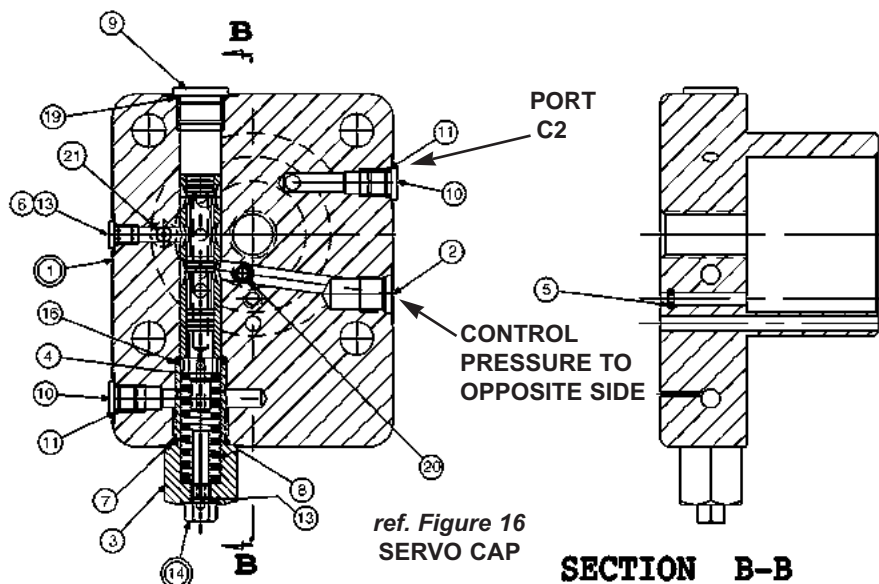

ELECTROHYDRAULIC STROKER CONTROL

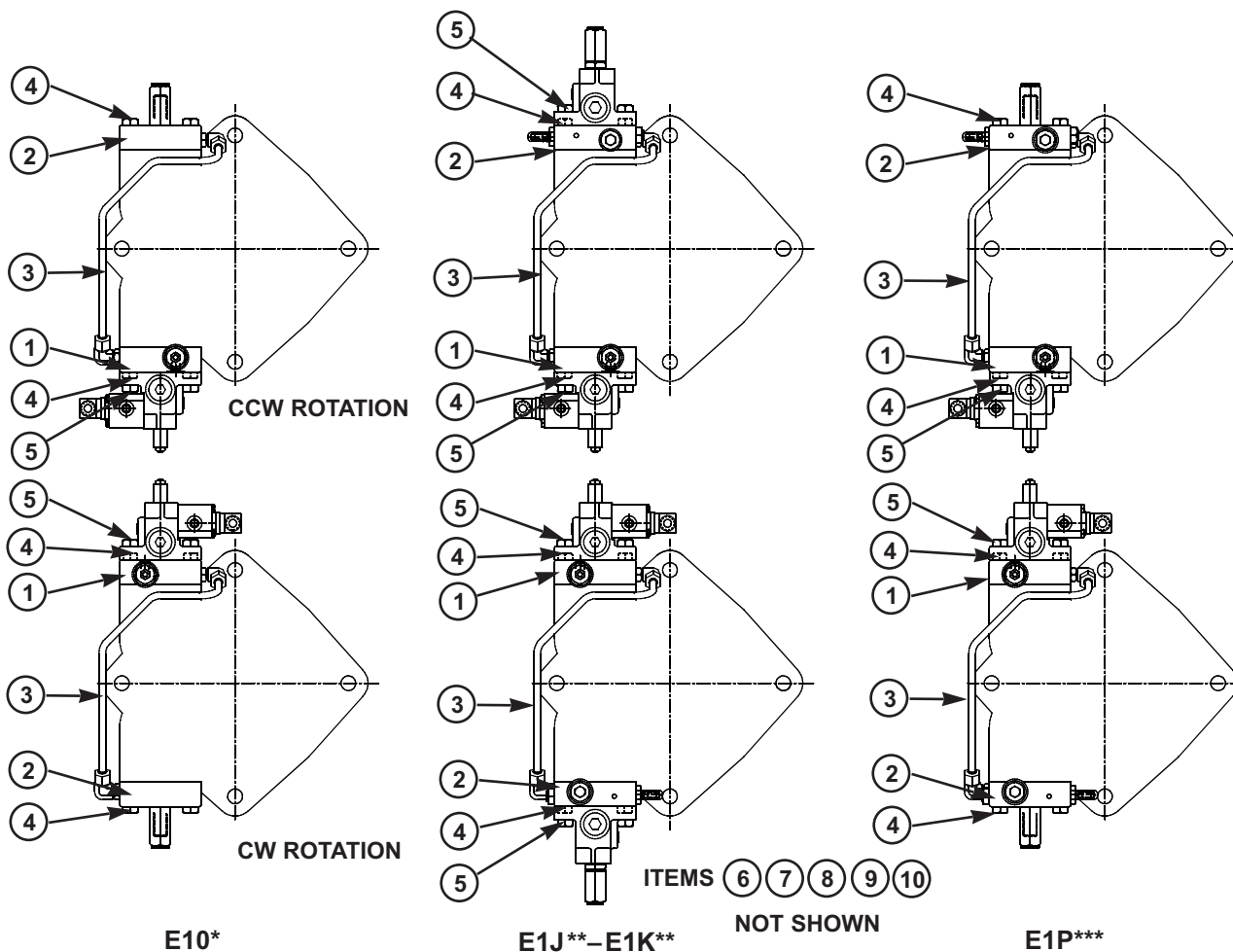

PARTS LIST *electrohydraulic stroker*

ITEM	DESCRIPTION	P09	P140	QUANTITY			
		PART NO.	PART NO.	E10*	E1J**	E1K**	E1P***
1	#Electrohydraulic Stroker (Fig. 18)	S22-16001	S22-16002	1	1	1	1
2	#Control Cap (Fig. 26)	S22-15256	S22-15272	1	—	—	—
	#Low Torque Override (Fig. 29)	S22-16183	S22-16184	—	1	—	—
	#High Torque Override (Fig. 29)	S22-16009	S22-16010	—	—	1	—
	#Compensator Override (Fig. 27)	S22-16007	S22-16008	—	—	—	1
3	Tube Assembly (Fig. 24, 25)	S22-16084	S22-16086	1	1	1	1
4	Screw-H.H.C., M12 x 60 mm	363-12210	363-12210	6	4	4	6
5	Screw-H.H.C., M12 x 80 mm	363-12225	363-12225	2	4	4	2
6	Control Piston	032-91881	032-91881	1	1	1	1
7	O-Ring, 90 S-1 ARP 013	691-00013	691-00013	2	2	2	2
8	O-Ring, 70 S-1 ARP 152	671-00152	671-00152	2	2	2	2
9	Piston Ring	032-92856	032-92856	1	1	1	1
10	Piston Ring	032-92855	032-92855	1	1	1	1

*Also E50

**Also E5J, E5K

***Also E5P

#Includes items 4, 5, 7 and 8

ELECTROHYDRAULIC STROKER CONTROL

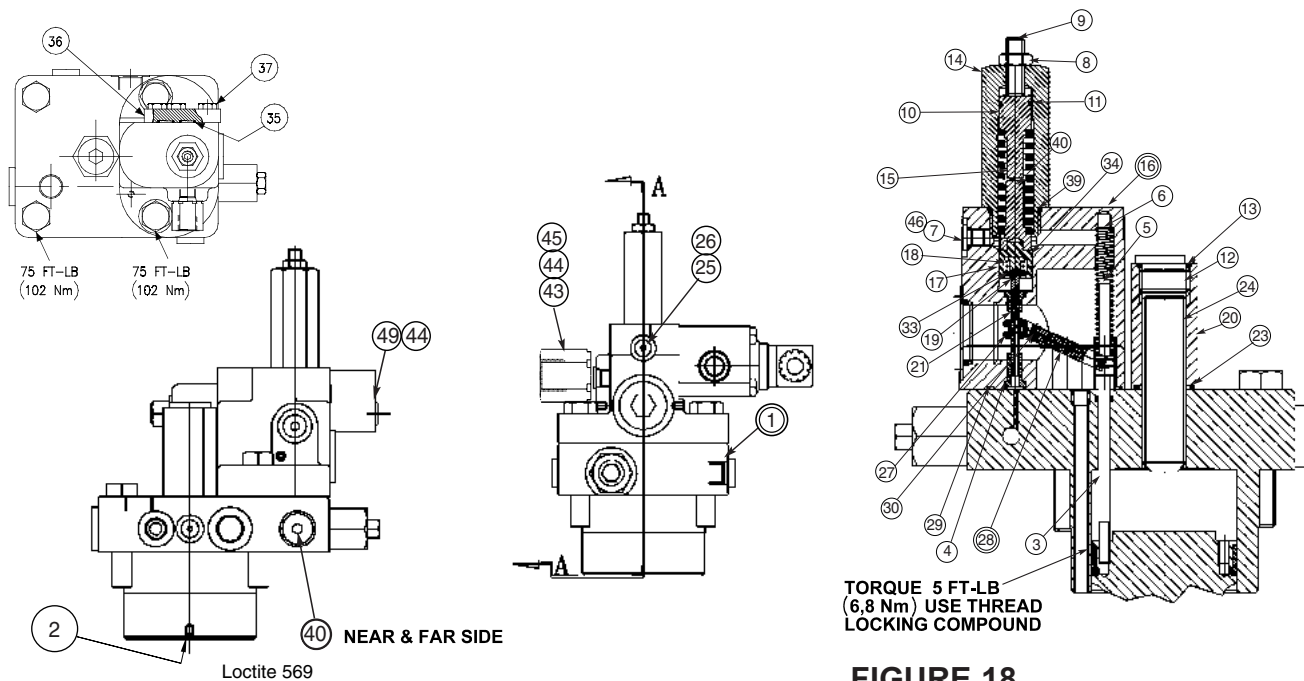

**TORQUE 5 FT-LB
(6.8 Nm) USE THREAD
LOCKING COMPOUND**

FIGURE 18

Electrohydraulic Stroker

PARTS LIST FOR FIGURE 18

*P09 electrohydraulic stroker
S22-16001
P140 electrohydraulic stroker
S22-16002*

ITEM	DESCRIPTION	P09		P140	
		PART NO.	QTY.	PART NO.	QTY.
1	Cap (Figure 16)	S22-16449	1	S22-16451	1
2	Orifice Screw (.078)	032-93071	1	032-93071	1
3	Screw	032-91461	1	032-91461	1
4	O-Ring, 70 S-1 ARP 010	671-00010	1	671-00010	1
5	Clevis pin	321-40000	1	321-40000	1
6	Spring, Compression	032-92100	1	032-92100	1
7	Plug	488-35046	1	488-35046	1
8	Nut, 5/16-24	335-13100	1	335-13100	1
9	Soc. Setscrew, 5/16-24	312-13160	1	312-13160	1
10	Retainer	032-92891	1	032-92891	1
11	O-Ring, 90 S-1 ARP 012	691-00013	1	691-00013	1
12	Plug, SAE-10	488-35055	1	488-35055	1
13	O-Ring, 90 S-1 ARP 910	691-00910	1	691-00910	1
14	Spring Housing	032-93473	1	032-93473	1
15	Spring	032-93494	1	032-93494	1
16	Body	S22-17293	1	S22-17293	1
17	Spool	032-91512	1	032-91512	1
18	Spring	225-92109	1	225-92109	1
19	Spring Retainer	032-91516	1	032-91516	1
20	Nut, 3/4-10	031-91049	1	031-91049	1
21	Spool	032-91438	1	032-91438	1
23	O-Ring, 70 S-1 ARP 118	671-00118	1	671-00118	1
24	Socket Setscrew, 3/4-10 x 3	311-45049	1	311-45049	1
25	Plug, SAE-12	032-93490	1	032-93490	1
26	O-Ring, 90 S-1 ARP 912	691-00912	1	691-00912	1
27	Sleeve	032-91437	1	032-91437	1
28	Arm assembly	S22-15520	1	S22-15520	1
29	O-Ring, 70 S-1 ARP 035	671-00035	1	671-00035	1
30	Dowel Pin, 1/8 Dia x 1.5 Lg.	324-20828	1	324-20828	1
33	Retaining Ring	356-30037	1	356-30037	1
34	Washer	032-91517	1	032-91517	1
35	O-Ring, 70 S-1 ARP 011	671-00011	2	671-00011	2
36	Block	032-91509	1	032-91509	1
37	Screw, 1/4-20 x 2-1/4	306-40187	3	306-40187	3
39	O-Ring, 90 S-1 ARP 908	691-00910	1	691-00910	1
40	Guide	032-93475	1	032-93475	1
41	Proportional Press. Cont. Valve	517-00095	1	517-00095	1
42	Coil, 24VDC	517-00096	1	517-00096	1
	Coil, 12VDC	517-00097		517-00097	
43	Connector	167-01008-8		167-01008-8	1
44	O-Ring, 90 S-1 ARP 904	691-00904	1	691-00904	2
45	Plug, SAE-4	488-35061	1	488-35061	1
46	Screw, SHC 10-32 x 1/4	312-09041	2	312-09041	2
49	Fitting	-		032-91507	1
50	O-Ring	691-00902	1	691-00902	1

DISASSEMBLY

1. See Figure 18. Remove 3 screws (37) holding block (36) to body (16).
2. Remove 2 screws holding body (16) to cap assembly (1).
3. Remove all parts from body (16) except pin (30) and arm assembly (28). It is not necessary to remove these parts unless broken or worn. Examine parts for wear or damage.
4. Remove screw (3). Examine head for excessive wear, and body for smooth sealing surface with O-ring.
5. See Figure 16. Remove tube lines to cap assembly.
6. Remove screws holding cap assembly to pump body.
7. Remove cap assembly (1). Remove plug (3) with attached parts. Remove spring (8) and spool (4).
8. Do not remove sleeve in body (1). Sleeve is pressed into cap and finished to size. If sleeve or cap is worn, replace the cap-sleeve assembly (1).

ASSEMBLY

See page 3 for tightening torque on plugs

1. See Figure 16. Install plug (6) and o-ring (13) in cap.
2. Install spool (4) into bore as shown. Install spring (8) over end of spool.
3. Install plug with stop (14) and O-ring (13) into plug (3).
4. Install O-rings (7) and (16) on plug (3). Install plugs (3) and (9) into body (1).
5. Install orifices (20) and (21) and plugs (10). Torque plugs. Install O-ring (5) in cap.
6. Note proper location for control on pump (pg. 20). Install O-rings on interface between cap and pump control pad. Install cap on pump control pad, guiding the control piston into the bore.
7. Torque two assembly bolts to 75 lb. ft. (102 N m).
8. See Figure 18. Apply thread locking compound on threads of screw (3), lubricate the shank, thread through the cap into the control piston, and torque to 5 lb. ft. (6.78 N m).
9. Install minimum stop screw (24) and turn clockwise to stroke pump to full volume. Measure height from control cap to top of screw (3). With control piston at full stroke, dimension must be .67 +/- .03 in. (16.9 +/- 0.76 mm). Back out minimum stop screw (24) till there is no contact with control piston.
10. Press dowel (30) into body (16), through the link (28), to 1/4" (6.35 mm) below surface, apply hydraulic sealant to threads of screws (46) and install over dowel (30).
11. Press spool (21) into retainer (19). Caution: do not use excessive force. Place spool/retainer assembly into spool (17) with spring (18) and washer (34). Secure with retaining ring (33).
12. While sleeve (27) is engaged into dowel on link (28), slide above spool assembly into bore of body (16), and through sleeve (27). Spool (21) must move freely and easily at all positions of the link (28).
13. Install proportional valve (41) in block. Torque to 20 ft. lbs. (27 N m).
14. Install coil (42) on proportional valve. Torque to 20-25 in. lbs. (2.2-2.8 N m) max.
15. Assemble all other components into body (16) per above drawing. Torque the plug (12).
16. While spring retainer is engaging clevis pin (5) under dowel of link (28), slide the other opening of spring retainer over the top of the screw (3). Attach body assembly (16) to cap (1) with two screws, and torque to 75 lb. ft. (102 N m).
17. Install tubing assembly (Figure 24, 25).

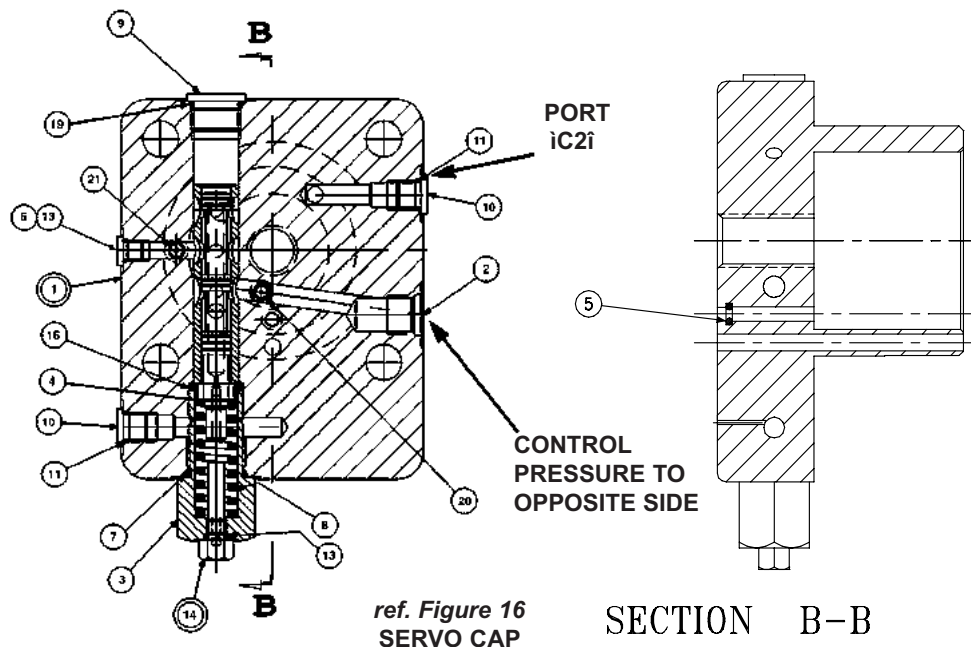

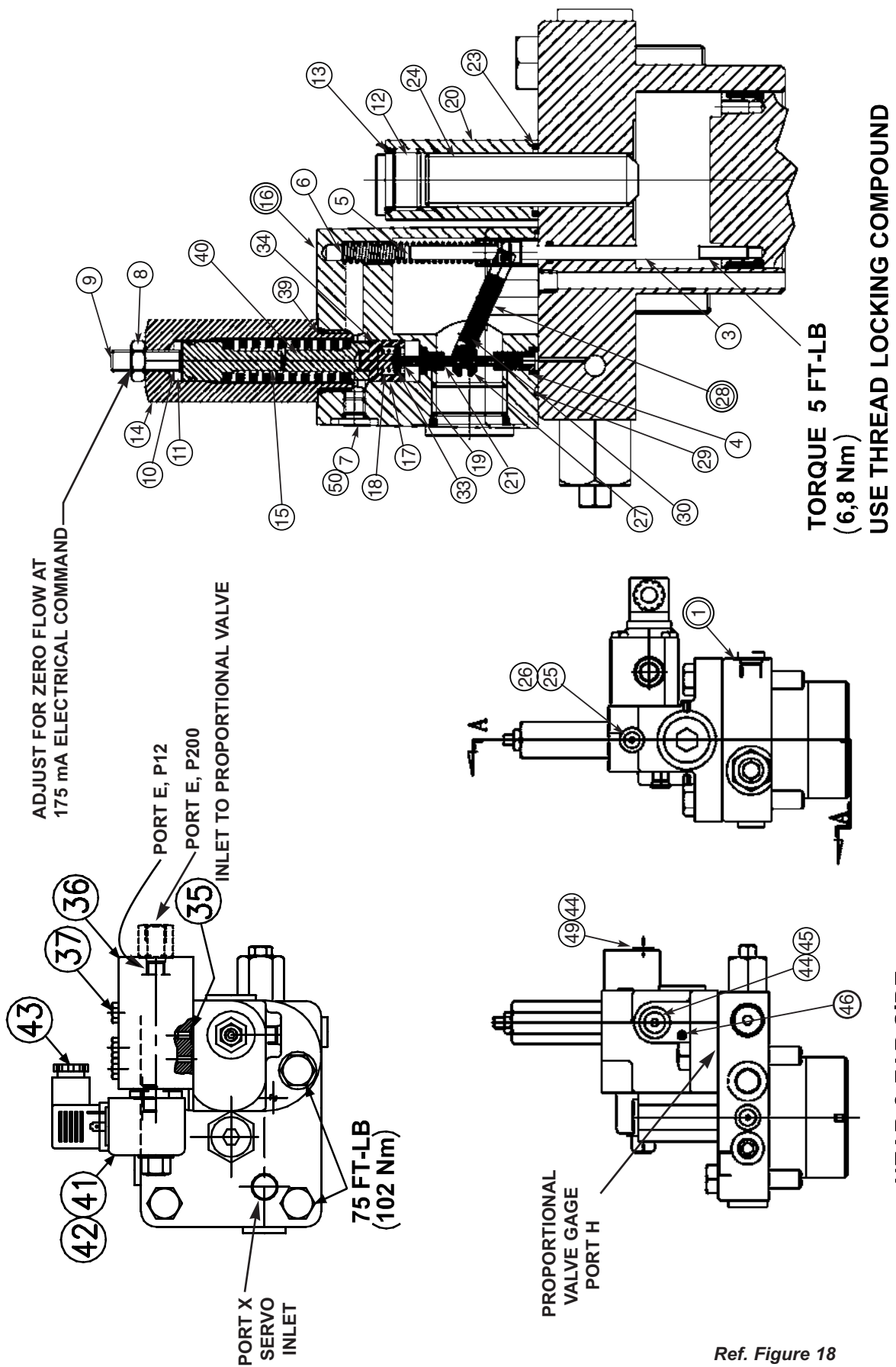

Ref. Figure 18
ELECTROHYDRAULIC STROKER

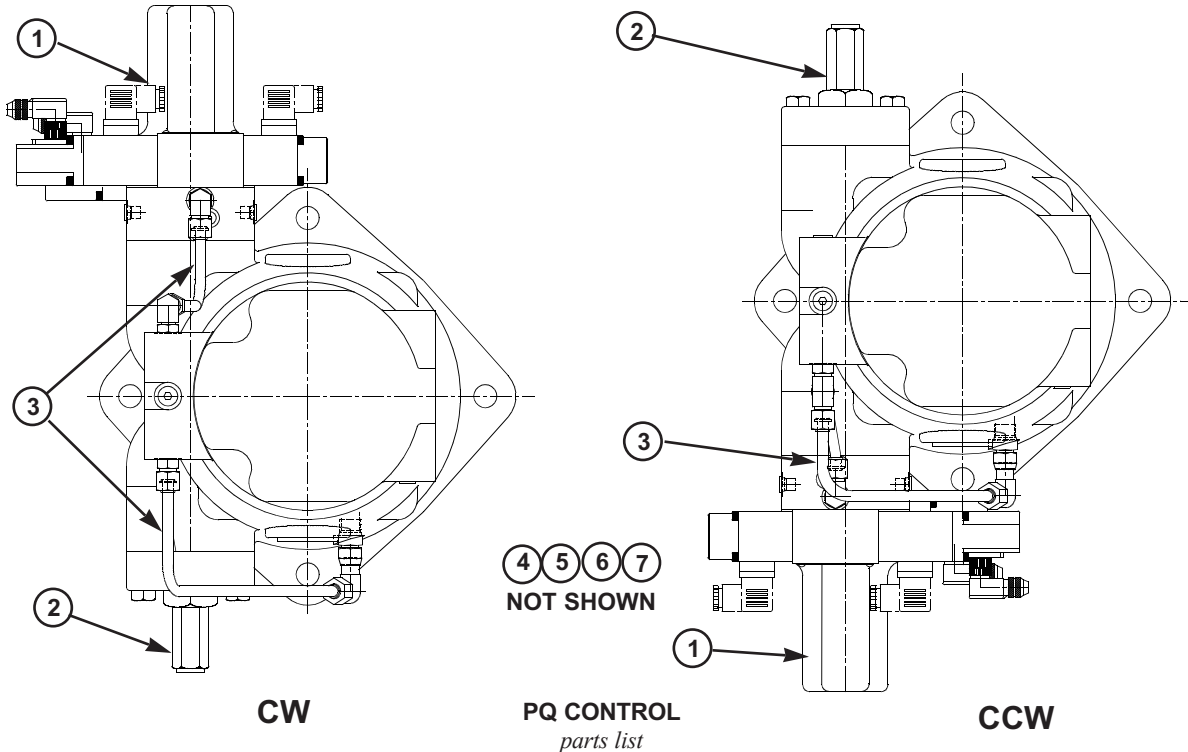

ITEM	DESCRIPTION	P09 PART NO.	P140 PART NO.	QTY.	
				CW	CCW
1	PQ Control (Fig.21)	S22-15963-	S22-15964	1	1
2	Max Volume Stop (Fig. 23)	S22-16126	S22-16126	1	1
3	CW Tube Assembly (Fig. 19)	S22-16458	S22-16459	1	-
	CCW Tube Assembly (Fig. 20)	S22-16460	S22-16461	-	1
4	Control Piston	032-	032-	1	1
5	O-Ring, 90 S-1 ARP 013	691-00013	691-00013	2	2
6	O-Ring, 70 S-1 ARP 152	671-00152	671-00152	2	2
7	Piston Ring	032-92856	032-92856	2	2

PARTS LIST FOR FIGURE 19
CW control tubing for PQ control

ITEM	DESCRIPTION	P09		P140	
		PART NO.	QTY.	PART NO.	QTY.
1	Float tube w/nut & sleeve	S22-16464	1	S22-16471	1
2	Servo tube w/nut & sleeve	S22-16472	1	S22-16471	1
3	Male elbow fitting	492-15382	2	492-15436	2
4	Fitting, male conn.	492-15433	1	492-15433	1
5	Swivel nut elbow fitting	492-15431	1	492-15428	1
6	O-ring, 90 S-1 ARP 012	691-00012	4	691-00012	4
7	O-ring	691-00906	3	691-00111	2
8	Fitting retaining ring 1/4	-	-	492-15416	2
9	Ring, soft seal VSTI 1/4	-	-	605-10061	1

PARTS LIST FOR FIGURE 20
CCW control tubing for PQ control

ITEM	DESCRIPTION	P16		P260	
		PART NO.	QTY.	PART NO.	QTY.
1	Float tube w/nut & sleeve	S22-16466	1	S22-16465	1
2	Servo tube w/nut & sleeve	S22-16478	1	S22-16477	1
3	Male elbow fitting	492-15382	2	492-15436	1
4	Fitting, male conn.	492-15438	1	492-15437	1
5	Swivel nut elbow fitting	492-15431	1	492-15428	1
6	O-ring, 90 S-1 ARP 012	691-00012	4	691-00012	4
7	O-ring	691-00906	3	691-00111	2
8	Fitting retaining ring 1/4	-	-	492-15416	2

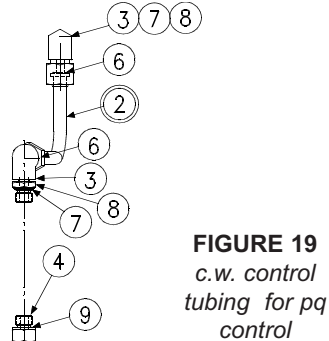

FIGURE 19
c.w. control
tubing for pq
control

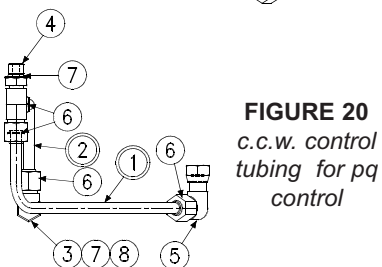
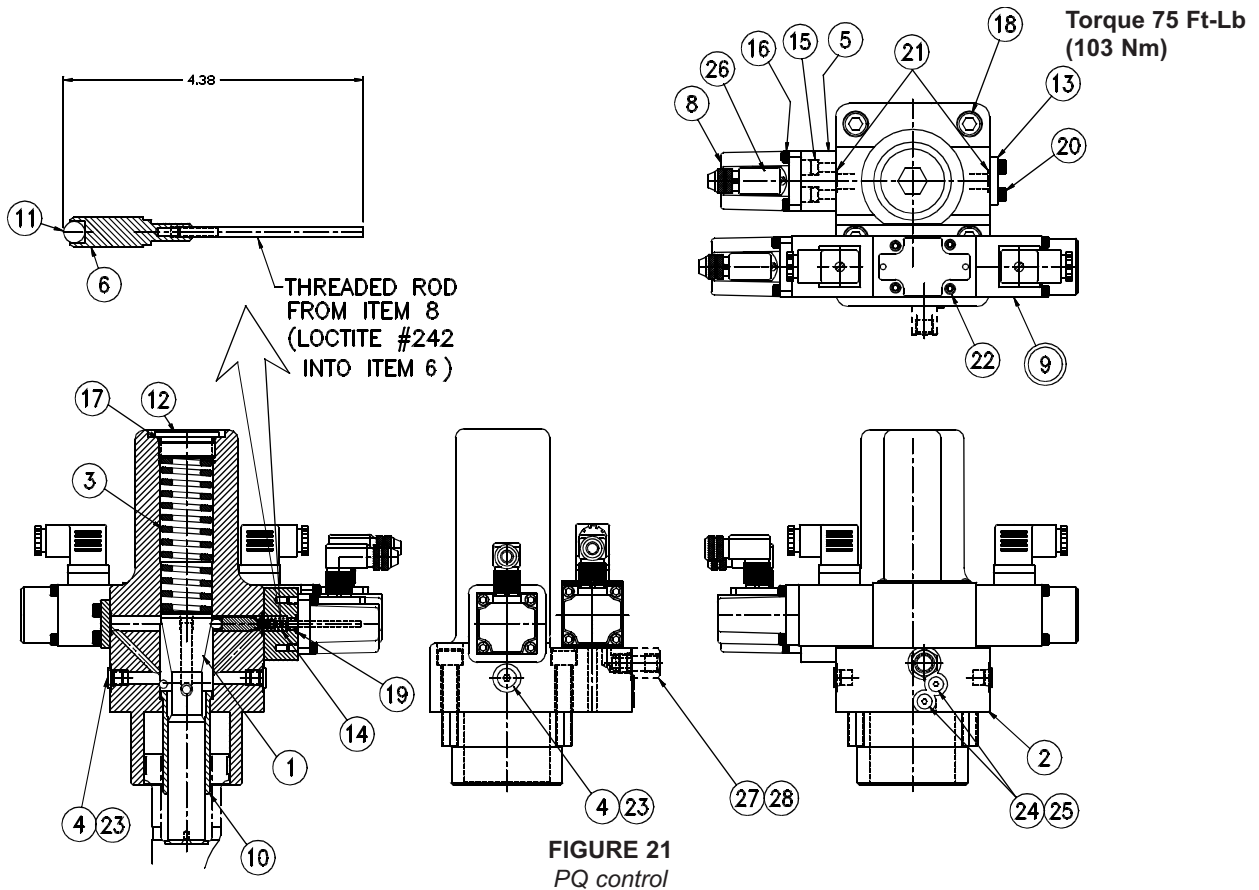

FIGURE 20
c.c.w. control
tubing for pq
control



PARTS LIST FOR FIGURE 21

P09 PQ control S22-15963

P140 PQ control S22-15964

ITEM	DESCRIPTION	P09		P140	
		PART NO.	QTY.	PART NO.	QTY.
1	Piston servo cone	032-92509	1	032-92509	1
2	Cap	032-92578	1	032-92578	1
3	Spring	225-92119	1	225-92119	1
4	Plug, SAE-4	488-35061	2	488-35061	2
5	Sensor base	032-92309	1	032-92309	1
6	Follower	032-92792	1	032-92792	1
8	DC/DC LVDT	788-30012	1	788-30012	1
9	Valve, 4DC01 F40 A (Fig. 22)	026-65909	1	026-65909	1
10	Buckdown sleeve	032-92503	1	032-92503	1
11	Ball, 5/16 chrome	201-10001	1	201-10001	1
12	Plug, SAE-20	488-35019	1	488-35019	1
13	Cover	032-92565	1	032-92565	1
14	Spring	225-92117	1	225-92117	1
15	Screw, SHC, M6 x 18 mm	361-08184	4	361-08184	4
16	Screw, SHC, M5 x 16 mm	361-07164	4	361-07164	4
17	O-ring, 90 S-1 ARP 920	691-00920	1	691-00920	1
18	Screw, SHC M12 x 60 mm	361-12284	4	361-12284	4
19	O-ring, 70 S-1 ARP 012	671-00012	1	671-00012	1
20	Screw, SHC, M6 x. 12 mm	361-08124	4	361-08124	4
21	O-ring, 70 S-1 ARP 014	671-00014	2	671-00014	2
22	Screw, SHC 10-24 x 1-1/4	358-10180	4	358-10180	4
23	O-ring, 90 S-1 ARP 904	691-00904	2	691-00904	2
24	Plug, SAE-2	488-35046	2	488-35046	2
25	O-ring, 90 S-1 ARP 902	691-00902	2	691-00902	2
26	Connector	721-30108	1	721-30108	1
27	Fitting, Adapter	-	-	492-15435	1
28	O-ring, 90 S-1 ARP 906	-	-	691-00906	1

DISASSEMBLY

1. See Figure 21. With pump on full stroke, remove plug (12) and spring (3) from cap (2).
2. Remove LVDT feedback assembly (8) from cap. Remove sensor base (5), spring (14) and feedback follower assembly (6 and 11)
3. Remove tubing assembly. Remove proportional valve with LVDT, item (9).
4. Remove screws (18) and slip cap off pump.
5. Examine servo cone piston (1) and sleeve (10) for wear or binding in the bore.

ASSEMBLY

See page 26 for tightening torque on plugs

1. Press sleeve (10) into cap (2). Slip piston (1) into cap and check for free travel over the full to zero stroke range.
2. Note proper location of cap on pump (pg. 24). Install O-rings to interface between cap and pump. Install cap on pump. Torque assembly bolts (18) to 75 ft-lbs, 103 Nm.
3. Insert spring (3) over spool (1) and install plug (12) with O-ring (17).
4. Thoroughly degrease feedback follower assembly (6) and rod from (8). Apply loctite 242 on threads. Assemble to the dimensions indicated. Allow loctite to set then check to see that rod assembly is firmly retained.
5. Use vaseline to retain ball (11) in guide (6). Insert guide in cap (2). Sensor may be installed on either side.
6. Install O-rings (21) to cover (13) and sensor base (5). Install to cap (1). Torque screws (15) and (20) to 106 in.-lb, 12 Nm.
7. Install stroke sensor LVDT (8) with O-ring (19) over sensor rod on cap. Torque screws (16) to 62,8 in.-lb, 7,1 Nm.
7. Install proportional valve with LVDT, (9). Torque screws (22) to 66 in.-lb, 7,5 Nm.
8. For 140 series, install adapter, (27).
9. Install tubing assembly (Figure 19, 20).

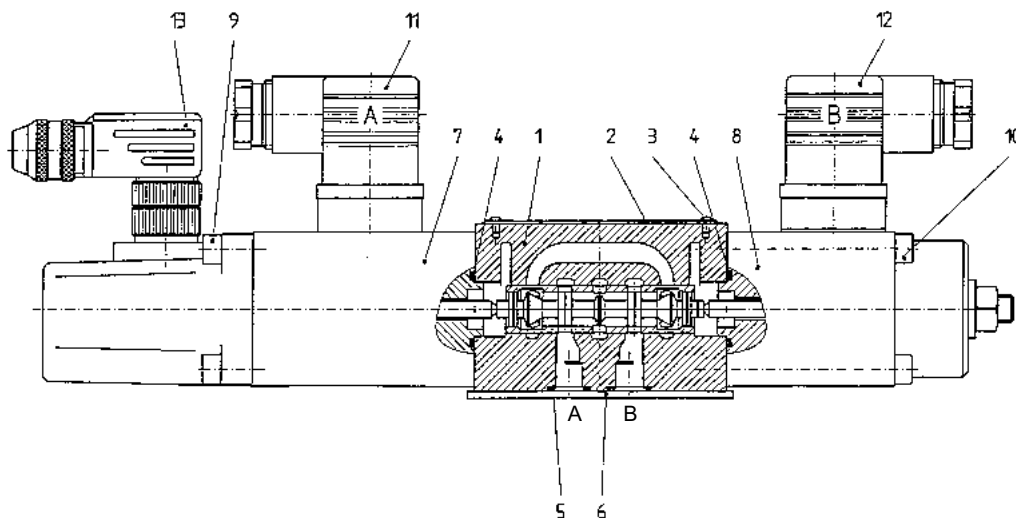
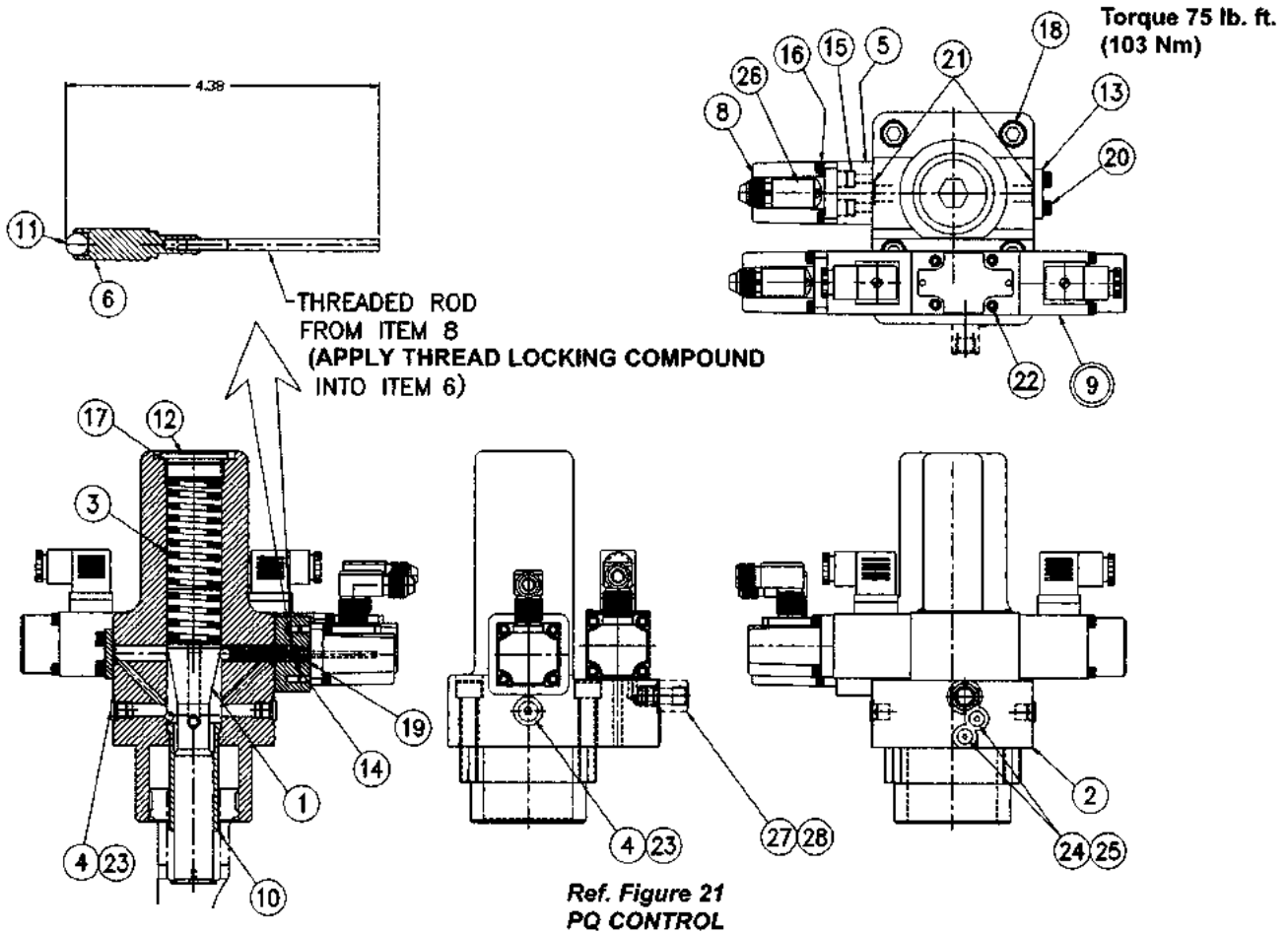

FIGURE 22
proportional valve with LVDT

PARTS LIST FOR FIGURE 22
proportional valve with LVDT 026-65909

ITEM	DESCRIPTION	PART NO.	QTY.
1	Body, micro-lap 40L	S26-58777	1
2	Data plate	036-84770	1
3	Drive screw	320-10203	2
4	O-ring, 90 S-1 ARP 018	691-00018	2
5	O-ring, 90 S-1 ARP 012	691-00012	4
6	Dust plate	036-39820	1
7	Solenoid with LVDT	120-03044-8	1
8	Solenoid without LVDT	120-03043-8	1
9	Screw, SHC, M5 x 80mm	361-00033-8	4
10	Screw, SHC, M5 x 55mm	361-00013-8	4
11	Plug-in connector, "A" (grey)	167-01007-8	1
12	Plug-in connector, "B" (black)	167-01008-8	1
13	Connector, LVDT	167-01106-8	1



CONTROL CAP DISASSEMBLY

1. See Figure 23. Remove nut (9) and maximum volume screw (11).
2. Remove guide (1).
3. Remove 4 screws (12) holding cap to pump.
4. Remove cap assembly from pump. Check piston and sleeve for wear and free motion.

ASSEMBLY

See page 3 for tightening torque on plugs

1. Install plug (8) and o-ring (13). Press sleeve (4) into cap to shoulder. Install piston (2), checking for free motion.
2. Install O-rings on interface between cap and pump control pad. Install cap on pump housing as indicated on the applicable view (pg. 20), guiding the control piston into the bore.
3. Torque the assembly bolts (12) to 75 lb. -ft. (103 Nm).
4. Install O-ring (6) on guide (1). Install guide in cap (5). Torque guide (1) to 140 lb. ft. (190 Nm).
5. Install screw (11) in cap. Install O-ring (10) on nut (9). Install nut (9) on screw.
6. Adjust screw till pump is slightly off full stroke and lock nut (9).
7. Install O-ring (7) on plug (3). Install plug in nut (9). Torque plug (3) to 75 lb.-ft. (103Nm).

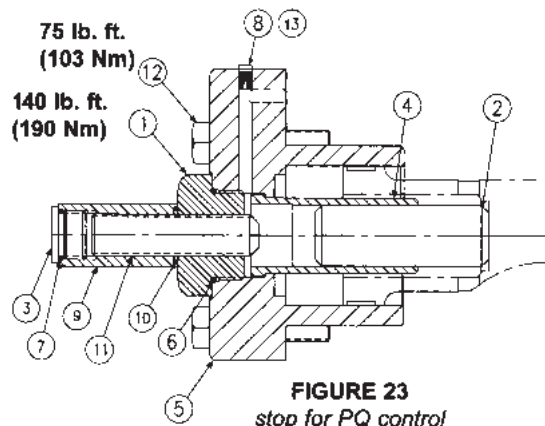

FIGURE 23
stop for PQ control

PARTS LIST FOR FIGURE 23
stop S22-16126 for PQ control

ITEM	DESCRIPTION	PART NO.	QTY.
1	Guide	032-92519	1
2	Buckdown piston	032-92554	1
3	Plug, SAE-10	488-35055	1
4	Sleeve	032-92503	1
5	Control Cap	032-92248	1
6	O-ring, 90 S-1 ARP 920	691-00920	1
7	O-ring, 90 S-1 ARP 910	691-00910	1
8	Plug	488-35046	1
9	Nut	031-91049	1
10	O-ring, 70 S-1 ARP 118	671-00118	1
11	Screw, 3/4-10 x 3	311-45049	1
12	Screw, SHC M12 x 60mm	363-12210	4
13	O-ring	691-00902	1

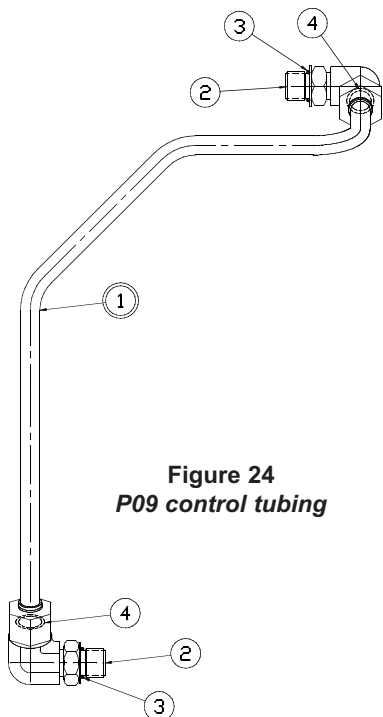

Figure 24
P09 control tubing

PARTS LIST FOR FIGURE 24
P09 control tubing S22-16084

ITEM	DESCRIPTION	PART NO.	QTY.
1	Servo tube w/nut & sleeve	S22-16085	1
2	Elbow fitting	492-15382	2
3	O-ring, 90 S-1 ARP 906	691-00906	2
4	O-ring, 90 S-1 ARP 012	691-00012	2

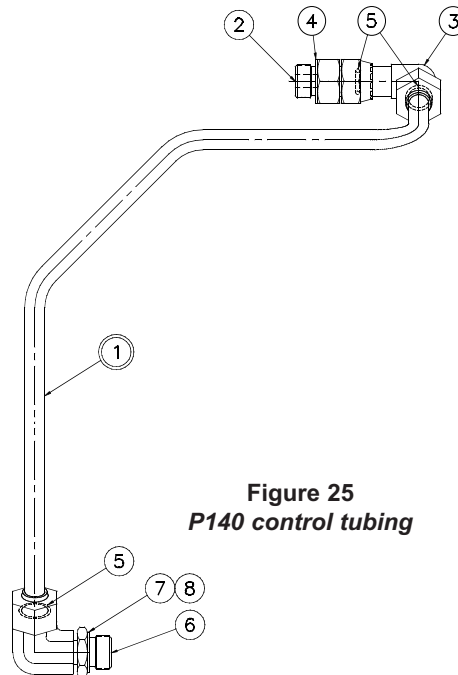

Figure 25
P140 control tubing

PARTS LIST FOR FIGURE 25
P140 control tubing S22-16086

ITEM	DESCRIPTION	PART NO.	QTY.
1	Servo tube w/nut & sleeve	S22-16087	1
2	Male connection fitting	492-15427	1
3	Swivel nut elbow fitting	492-15428	1
4	Ring, soft seal VSTI 3/8	605-10062	1
5	O-ring, 90 S-1 ARP 012	691-00012	3
6	Male elbow fitting	492-15426	1
7	Fitting retaining ring 3/8	492-15417	1
8	O-ring, 90 S-1 ARP 113	691-00113	1

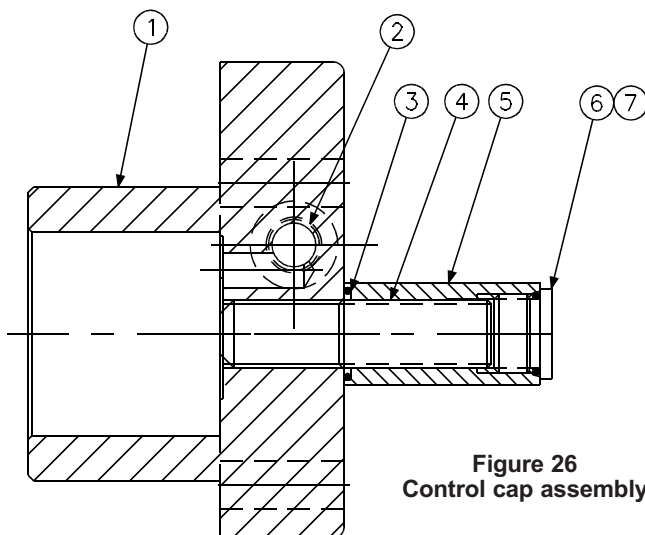

Figure 26
Control cap assembly

PARTS LIST FOR FIGURE 26
P09 control cap assembly S22-15256
P140 control cap assembly S22-15272

ITEM	DESCRIPTION	P09		P140	
		PART NO.	QTY.	PART NO.	QTY.
1	Control Cap	032-91764	1	032-91766	1
2	Plug	449-00015	1	449-00599	1
3	O-ring, 70 S-1 ARP 118	671-00118	1	671-00118	1
4	Screw, 3/4-10 x 3	311-26320	1	311-26320	1
5	Nut	031-91049	1	031-91049	1
6	Plug, SAE-10	488-35055	1	488-35055	1
7	O-ring 90 S-1 ARP 910	691-00910	1	691-00910	1

CONTROL CAP DISASSEMBLY

1. See Figure 26. Remove nut (5) and Max. volume screw (4).
2. Remove 4 screws holding cap to pump.
3. Remove cap assembly from pump.

ASSEMBLY

See page 26 for tightening torque on plugs

1. Install O-rings on interface between cap and pump control pad. Install cap on pump housing as indicated on the applicable view (pg. 24), guiding the control piston into the bore.
2. Torque the assembly bolts to 75 lb. •ft., 102 Nm.
3. Install screw (4) in cap. Install O-ring (3) on nut (5). Install nut (5) on screw.
4. Adjust screw till pump is slightly on stroke and lock nut (5).
5. Install O-ring (7) on plug (6). Install plug in nut (5). Torque plug (6).

COMPENSATOR OVERRIDE CONTROL

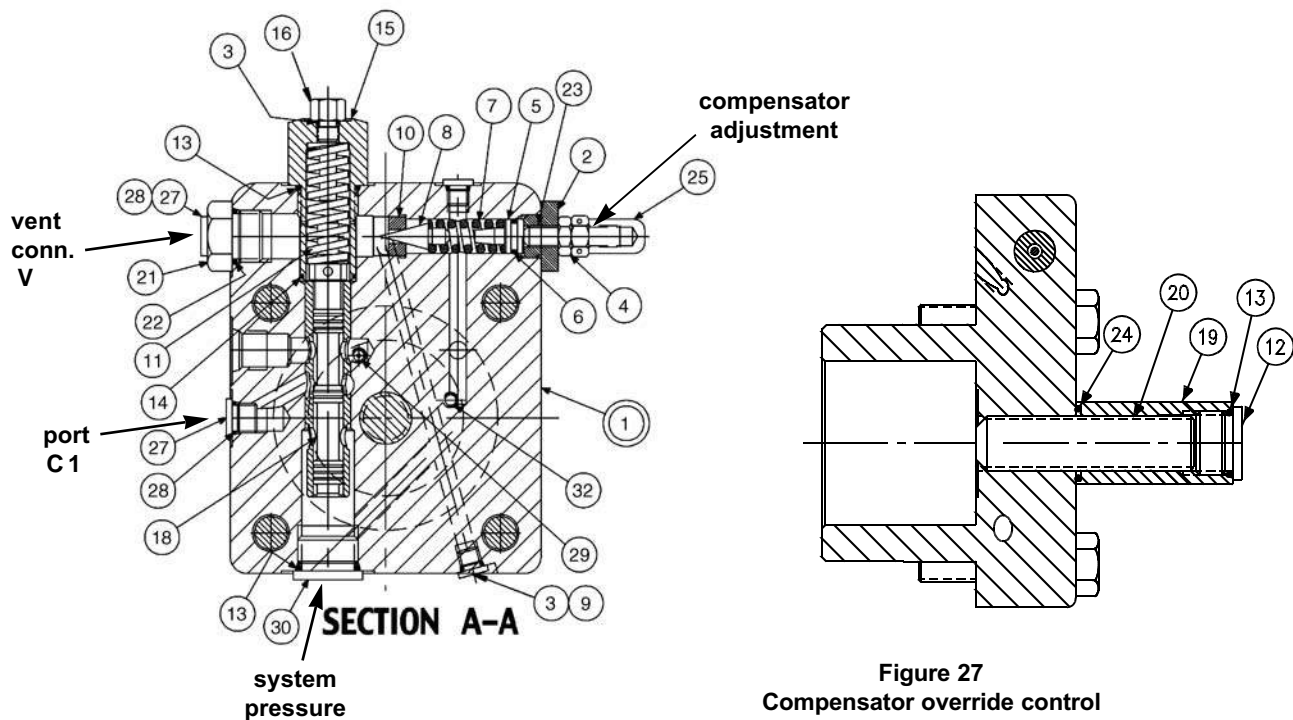

Figure 27
Compensator override control

PARTS LIST FOR FIGURE 27
compensator override control
P09 compensator override S22-16007
P140 comp. override S22-16008

ITEM	DESCRIPTION	P09		P140	
		PART NO.	QTY.	PART NO.	QTY.
1	Cap-Sleeve Assembly	S22-15989	1	S22-15990	1
2	Adustment Plug	032-91814	1	032-91814	1
3	O-ring, 90 S-1 ARP 902	691-00902	3	691-00902	3
4	Nut, 5/16-24	335-13100	1	335-13100	1
5	Seal Piston	031-59367	1	031-59367	1
6	O-Ring, 90 S-1 ARP 012	691-00012	1	691-00012	1
7	Spring	032-91798	1	032-91798	1
8	Cone	036-12288	1	036-12288	1
9	Plug	488-35046	2	488-35046	2
10	Seat	036-11692	1	036-11692	1
11	Spring	032-92874	1	032-92874	1
12	Plug, SAE-10	488-35055	1	488-35055	1
13	O-Ring, 90 S-1 ARP 910	691-00910	3	691-00910	2
14	O-Ring, 90 S-1 ARP 017	691-00017	1	691-00017	1
15	Plug	032-92806	1	032-92806	1
16	Plug with stop	S22-16402	1	S22-16402	1
18	Spool	032-92805	1	032-92805	1
19	Cover	032-91049	1	032-91049	1
20	Screw, 3/4-10 x 3	311-45049	1	311-45049	1
21	Plug	492-15423	1	492-15425	1
22	O-ring, 90 S-1 ARP 908	691-00908	1	-	-
23	Soc. Setscrew 5/16-24 x 1-1/4	312-13180	1	312-13180	1
24	O-ring, 70 S-1 ARP 118	671-00118	1	671-00118	1
25	Acorn Nut	036-33474	1	036-33474	1
27	Plug, SAE-4, (1/4 BSPP)	488-35061	2	447-01004	2
28	O-ring, 90 S-1 ARP 904	691-00904	2	-	-
29	Orifice	035-40489	1	035-40489	1
30	Plug, SAE-10, (1/2 BSPP)	488-35055	1	447-01008	1
32	Screw, SHC	311-10041	1	311-10041	1

DISASSEMBLY

1. See Figure 27. Remove tube line to cap.
2. Remove maximum volume stop assembly (items 12, 13, 19, 20, 24).
3. Remove cap assembly.
4. Remove plug (15) and attached parts. Remove spring (11) and spool (18).
5. Remove adjusting plug (2) and attached parts. Remove seal piston (5). Note: a 10-24 screw may be attached to assist in pulling the piston. Remove spring (7) and cone (8).
6. Do not remove sleeve in body (1). Sleeve is pressed into cap and finished to size. If sleeve, snout or cap is worn, replace the cap-sleeve assembly (1).
7. Examine seat (10) for wear. Do not remove unless damaged.

ASSEMBLY

See page 3 for tightening torque on plugs

1. Install plugs (9) and o-rings (3) in body. Install orifice (29) and plug (32) as shown.
2. Press seat (10) into bore to shoulder in bore.
3. Install spool (18) into bore as shown. Install spring (11) over end of spool. Install plug with stop (16) into plug (15). Install plug (15) into cap.
4. Install O-ring (6) on seal piston (5).
5. Lubricate O-ring and install cone (8), spring (7) and seal piston into bore in cap (1), being careful that cone enters seat (10).
6. Install remaining parts. Torque plugs (12) (21) (27) and (30).
7. Note proper location for cap on pump (pg. 20). Install O-rings on interface between cap and pump control pad.
8. Install cap assembly on pump, guiding the control piston into the bore.
9. Torque mounting bolts to 75 lb. ft. (102 N m).
10. Install tubing assembly (Figure 24, 25).

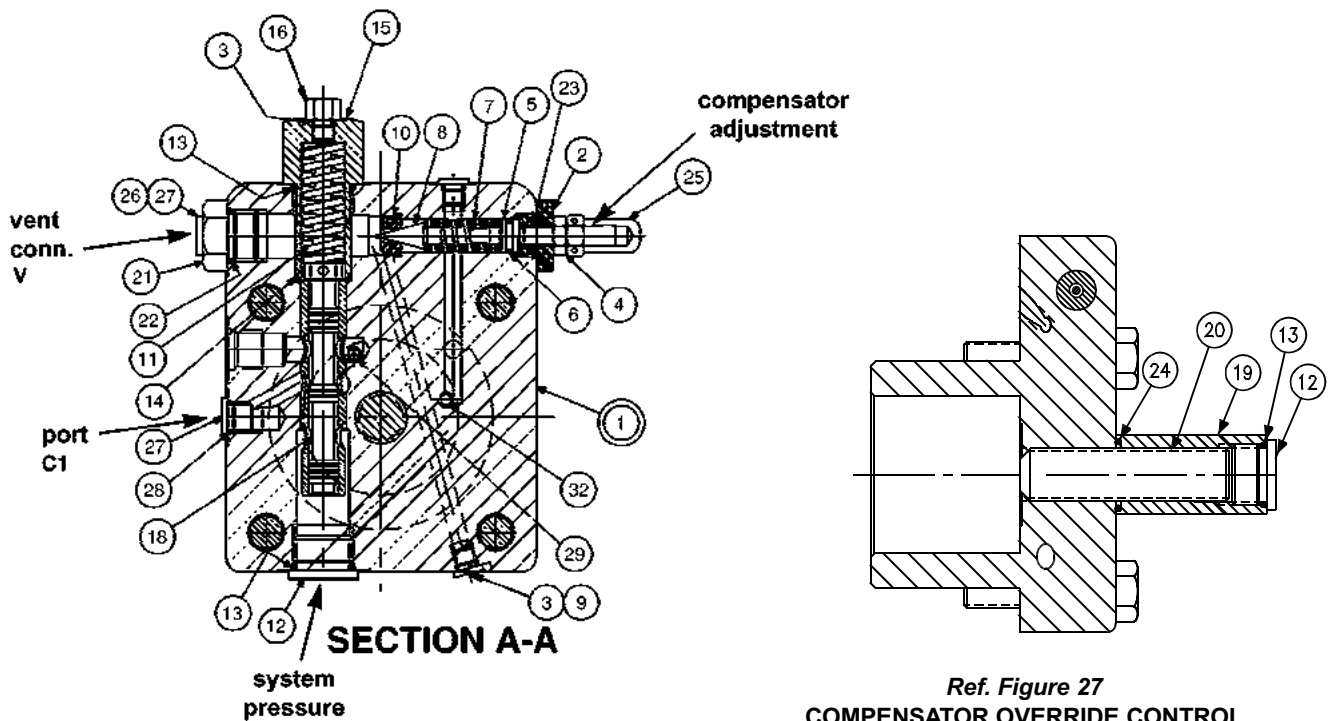

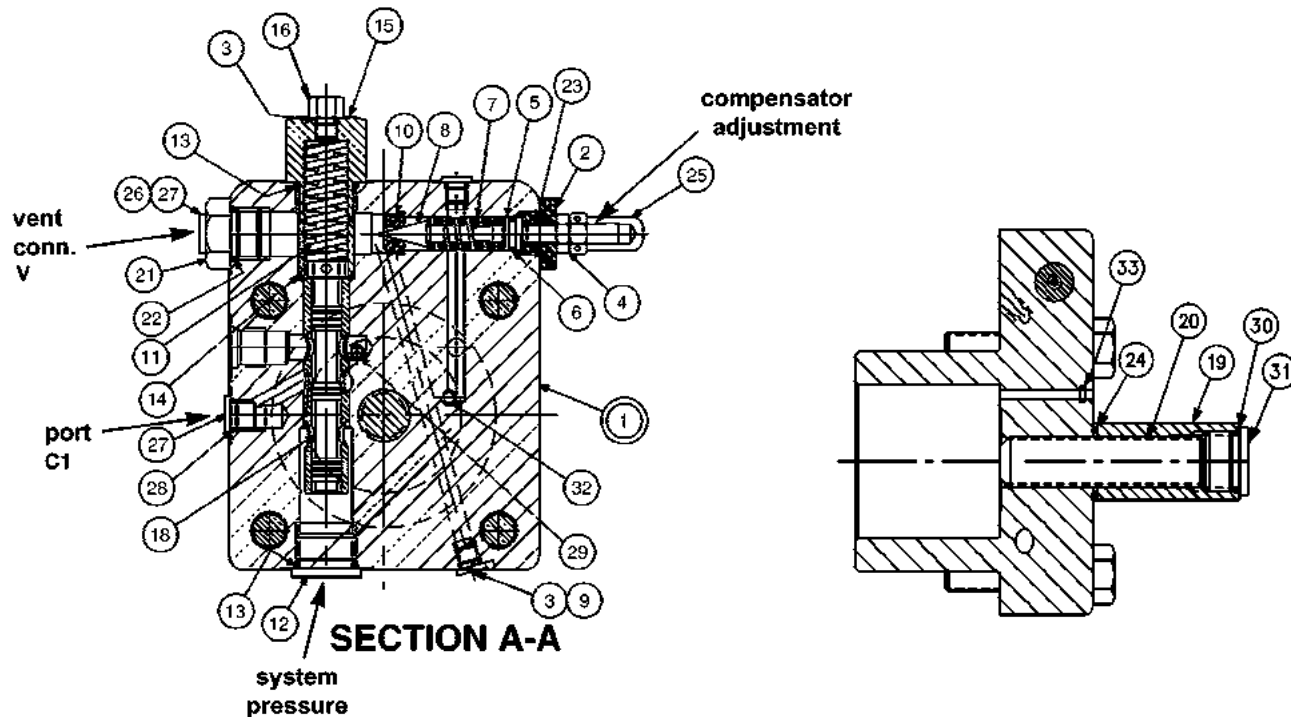

FIGURE 28
torque limiter override cap

PARTS LIST FOR FIGURE 28

torque limiter override cap

P09 cap S22-15993

P140 cap S22-15994

ITEM	DESCRIPTION	P09		P140	
		PART NO.	QTY.	PART NO.	QTY.
1	Cap-Sleeve Assembly	S22-15991	1	S22-15992	1
2	Adjustment Plug	032-91814	1	032-91814	1
3	O-ring, 90 S-1 ARP 902	691-00902	3	691-00902	3
4	Nut, 5/16-24	335-13100	1	335-13100	1
5	Seal Piston	031-59367	1	031-59367	1
6	O-Ring, 90 S-1 ARP 012	691-00012	1	691-00012	1
7	Spring	032-91798	1	032-91798	1
8	Cone	036-12288	1	036-12288	1
9	Plug	488-35046	2	488-35046	2
10	Seat	036-11692	1	036-11692	1
11	Spring	032-92874	1	032-92874	1
12	Plug, SAE-10, (1/2 BSPP)	488-35055	1	447-01008	1
13	O-Ring, 90 S-1 ARP 910	691-00910	2	691-00910	1
14	O-Ring, 90 S-1 ARP 017	691-00017	1	691-00017	1
15	Plug	032-92806	1	032-92806	1
16	Plug with stop	S22-16402	1	S22-16402	1
18	Spool	032-92805	1	032-92805	1
19	Cover	032-91761	1	032-91761	1
20	Screw, 1/2-20 x 2-1/2	312-35066	1	312-35066	1
21	Fitting	492-15423	1	492-15425	1
22	O-ring 90 S-1 ARP 908	691-00908	1	-	-
23	Soc. Setscrew	312-13180	1	312-13180	1
24	O-Ring, 70 S-1 ARP 015	671-00015	1	671-00015	1
25	Acorn Nut	036-33474	1	036-33474	1
26	Plug	449-00015	1	449-00599	1
27	Plug, SAE-4, 1/4 BSPP	488-35061	2	447-01004	2
28	O-ring, 90 S-1 ARP 904	691-00904	2	-	-
29	Orifice	035-40489	1	035-40489	1
30	O-Ring, 90 S-1 ARP 905	691-00905	1	691-00905	1
31	Plug, SAE-5	488-35020	1	488-35020	1
32	Screw, SHC	311-10041	1	311-10041	1
33	O-Ring, 70 S-1 ARP 008	671-00008	1	671-00008	1

TORQUE LIMITER OVERRIDE

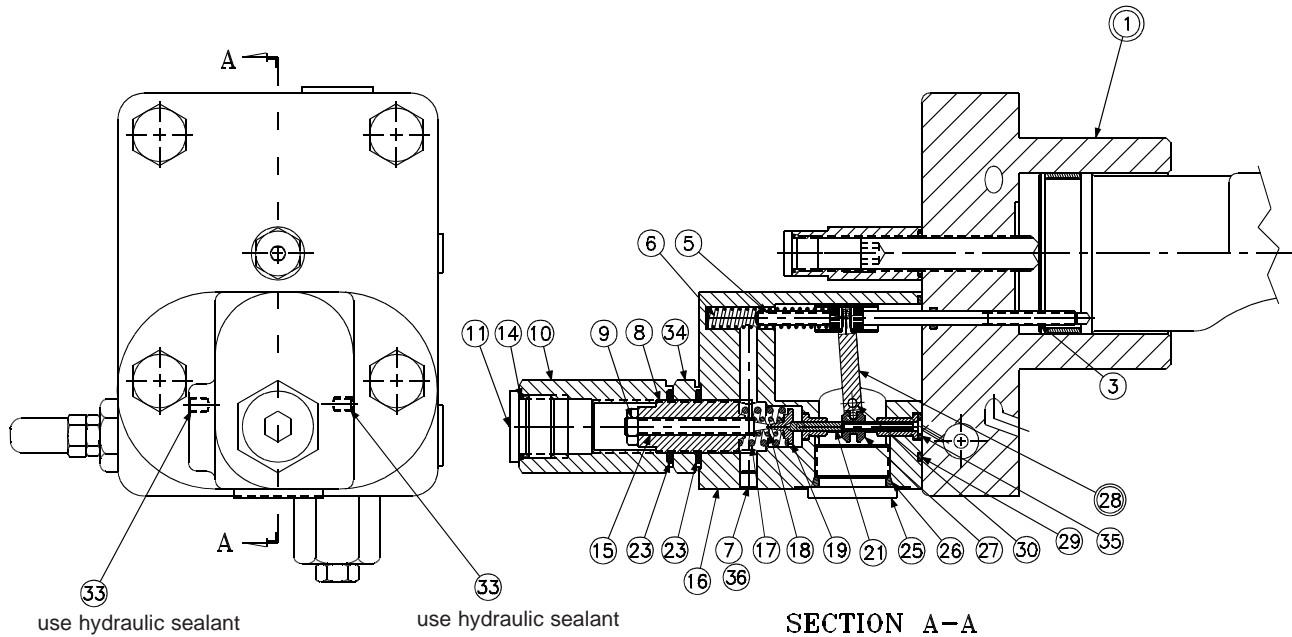

FIGURE 29
TORQUE LIMITER OVERRIDE

PARTS LIST FOR FIGURE 29

torque limiter override

P09 code J S22-16183

P09 code K S22-16009

P140 code J S22-16184

P140 code K S22-16010

ITEM	DESCRIPTION	P09	P140	QTY.	
		PART NO.	PART NO.	**J	**K
1	Cap (Figure 28)	S22-15993	S22-15994	1	1
3	Screw	032-91461	032-91461	1	1
5	Clevis pin	321-40000	321-40000	1	1
6	Spring, Compression	032-92100	032-92100	1	1
7	Plug	488-35046	488-35046	1	1
8	Screw	032-91445	032-91445	1	1
9	Nut, Hex Jam 1/4-20 UNC	340-00038	340-00038	1	1
10	Hex Nut, 3/4-16 UNF	032-91449	032-91449	1	1
11	Plug, SAE-8	488-35018	488-35018	1	1
14	O-Ring, 90 S-1 ARP 908	691-00908	691-00908	1	1
15	Screw, Primary Adjustment	032-91446	032-91446	1	1
16	Body assembly	S22-15397	S22-15397	1	1
17	Outer Spring J Version	032-91440	032-91440	1	
	Outer Spring K Version	032-91440	032-91440		1
18	Inner Spring J Version	032-92240	032-92240	1	
	Inner Spring K Version	032-91441	032-91441		1
19	Spring Retainer	032-91819	032-91819	1	1
21	Spool	032-91438	032-91438	1	1
23	O-ring, 70 S-1 ARP 118	671-00118	671-00118	2	2
25	Plug, SAE-12	488-35014	488-35014	1	1
26	O-Ring, 90 S-1 ARP 912	691-00912	691-00912	1	1
27	Sleeve	032-91437	032-91437	1	1
28	Arm assembly	S22-15520	S22-15520	1	1
29	O-Ring, 70 S-1 ARP 035	671-00035	671-00035	1	1
30	Dowel Pin	324-20828	324-20828	1	1
33	Screw, SHC 10-32 x 1/4	312-09041	312-09041	2	2
34	Nut	032-91645	032-91645	1	1
35	O-Ring, 70 S-1 ARP 010	671-00010	671-00010	1	1
36	O-Ring	691-00902	691-00902	1	1

DISASSEMBLY

1. See figure 29. Remove 2 screws holding torque limiter body (16) to cap assembly (1).
2. Remove all parts from torque limiter body (16) except pin (30) and arm assembly (28). It is not necessary to remove these parts unless broken or worn. Examine parts for wear or damage.
3. Remove screw (3). Examine head for excessive wear, and body for smooth sealing surface with O-ring.
4. See figure 28. Remove maximum volume stop assembly (items 19, 20, 24, 30, 31).
5. Remove cap assembly (1).
6. Remove plug (15) and attached parts. Remove spring (11) and spool (18).
7. Remove adjusting plug (2) and attached parts. Remove seal piston (5). Note: a 10-24 screw may be attached to assist in pulling the piston. Remove spring (7) and cone (8).
8. Do not remove sleeve in body (1). Sleeve is pressed into cap and finished to size. If sleeve, snout or cap is worn, replace the cap-sleeve assembly (1).
9. Examine seat (10) for wear. Do not remove unless damaged.

ASSEMBLY

See page 3 for tightening torque on plugs

1. See figure 28. Install plugs (9) and o-rings (3) orifice (29) and screw (32).
2. Press seat (10) into bore squarely against shoulder in bore.
3. Install spool (18) into bore as shown. Install spring (11) over end of spool. Install plug with stop (16) into plug (15). Install plug (15) into cap.
4. Install O-ring (6) on seal piston (5).
5. Lubricate O-ring and install cone (8), spring (7) and seal piston into bore in cap (1), being careful that cone enters seat (10). Install adjusting plug (2), screw (25), nut (4), and acorn nut (25).
6. Install plugs (12), (21) and (27) and torque.
7. Carefully install O-ring (33) into the cap.
8. Note proper location for cap (pg. 20). Install O-rings on interface between cap and pump control pad. Install cap assembly on pump, guiding the control piston into the bore. Torque two mounting screws to 75 lb. ft., (102 Nm).
9. Install maximum stop screw (20), cover (19), O-ring (24) and plug (31) with O-ring (30).
10. See figure 29. Apply thread locking compound on threads of screw (3), lubricate the shank, thread through the cap into the control piston, and torque to 5 lb. ft. (6,78 Nm).
11. Measure height from control cap to top of screw. With control piston at zero stroke, dimension must be .67 +/- .03 in. (16,9 +/- 0,76 mm).
12. Press dowel (30) into body (16), through the link assembly (28), to 1/4 (6.35 mm) below surface. Apply hydraulic sealant to threads of screws (33) and install over dowel (30).
13. While sleeve (27) is engaged into dowel on link (28), slide spool (21) into bore of body (16), and through sleeve (27). Spool (21) must move freely and easily at all positions of the link (28).
14. Assemble remaining parts per drawing. Torque plug (11).
15. While spring retainer is engaging clevis pin (5) under dowel of link (28), slide the other opening of spring retainer over the top of the screw (3). Attach body assembly (16) to cap (1), and torque assembly screws to 75 lb. ft. (102 Nm).
16. Install tubing assembly (Figure 24, 25).

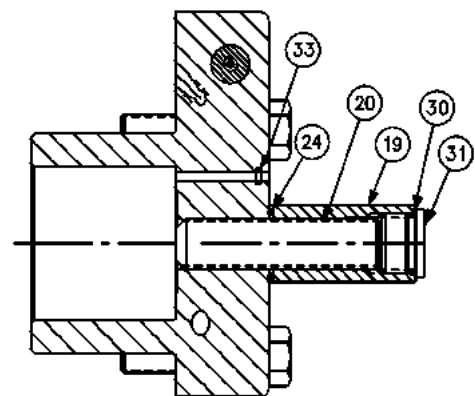
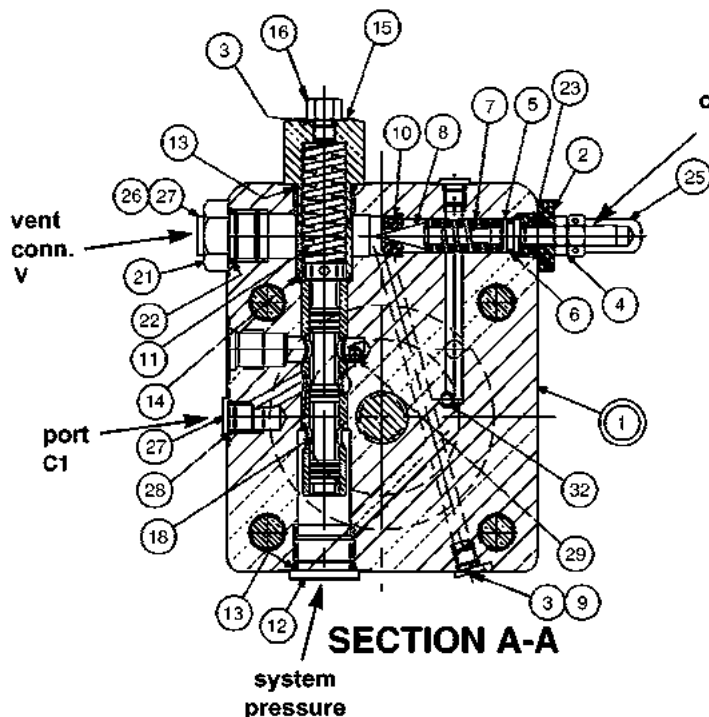

Ref. Figure 28
Torque limiter override cap

Test Conditions: (If using service facility test stand)

Fluid: Mobil 4259 DE (ISO VG-32 or equivalent)

RPM: 1450 or 1750 ± 50 RPM

Inlet Temp: 120° F ± 10° F, 49° C ± 4° C

Inlet Condition: Atmospheric to + 5 psi, 0,345 bar

Case Pressure: 25 psi ±5 psi, 1,72 bar ± 0,345 bar

Mount pump on test stand, or customer system. System line must have a relief valve. Connect system lines and case drain line. Fill pump case with clean oil. If pump is mounted vertically with the shaft up, vent the case by removing the plug from port "DG" to purge trapped air. Dry all oil from exterior of pump to permit checking for external leaks. If leaks are detected at any time, they shall be repaired before proceeding.

Adjust maximum volume stop to full displacement by backing off screw or handwheel CCW until there is no contact with control piston.

ROTARY SERVO TEST

The rotary servo mounts on the minimum stroke side of the pump. It utilizes a rotating shaft containing a cam to position a pin, and a sleeve positioned by a feedback link to the control cylinder. The sleeve/pin combination meters pilot flow to position a 4-way valve. This valve is ported to both ends of the control cylinder. The 4-way spool directs oil to/from the control cylinder such that it moves in a direction to maintain the metered position between the sleeve and spool. The pump stroke is thus established by the position of the shaft.

A compensator or torque limiter override may be installed on the opposite side of the control piston. When the set pressure or torque is reached, system pressure is directed into the piston to reduce stroke, overriding the servo commanded position.

Before testing the rotary servo, disable the compensator or torque limiter override, if applicable, by turning the compensator differential adjustment fully in. **CAUTION:** System must contain a relief valve to limit system pressure. System relief valve should be set to minimum pressure.

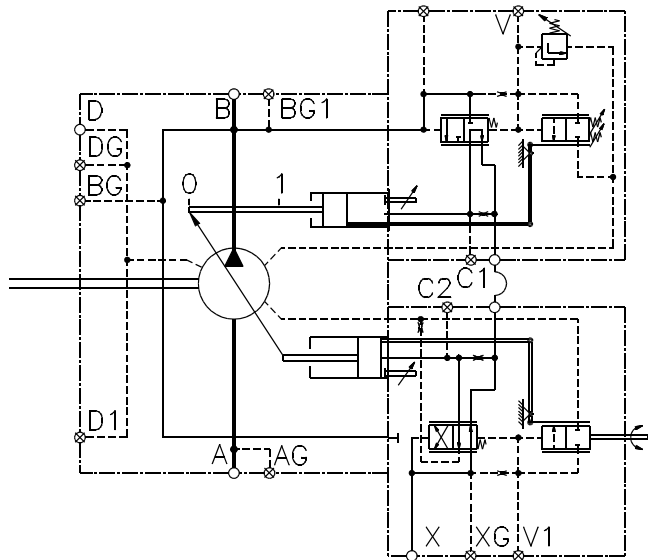

**HYDRAULIC CIRCUIT
ROTARY SERVO TORQUE
LIMITER OVERRIDE**

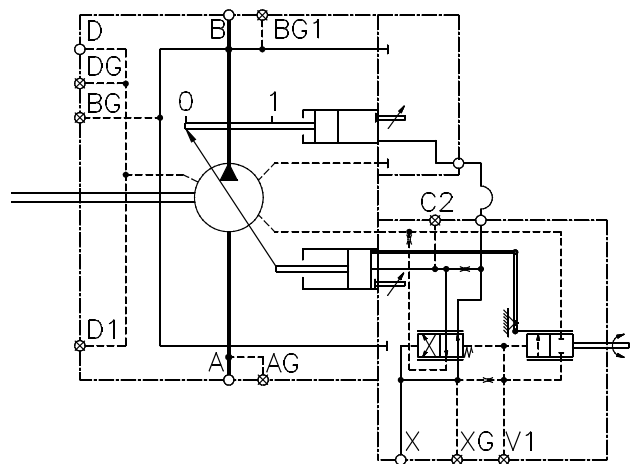

**HYDRAULIC CIRCUIT
ROTARY SERVO**

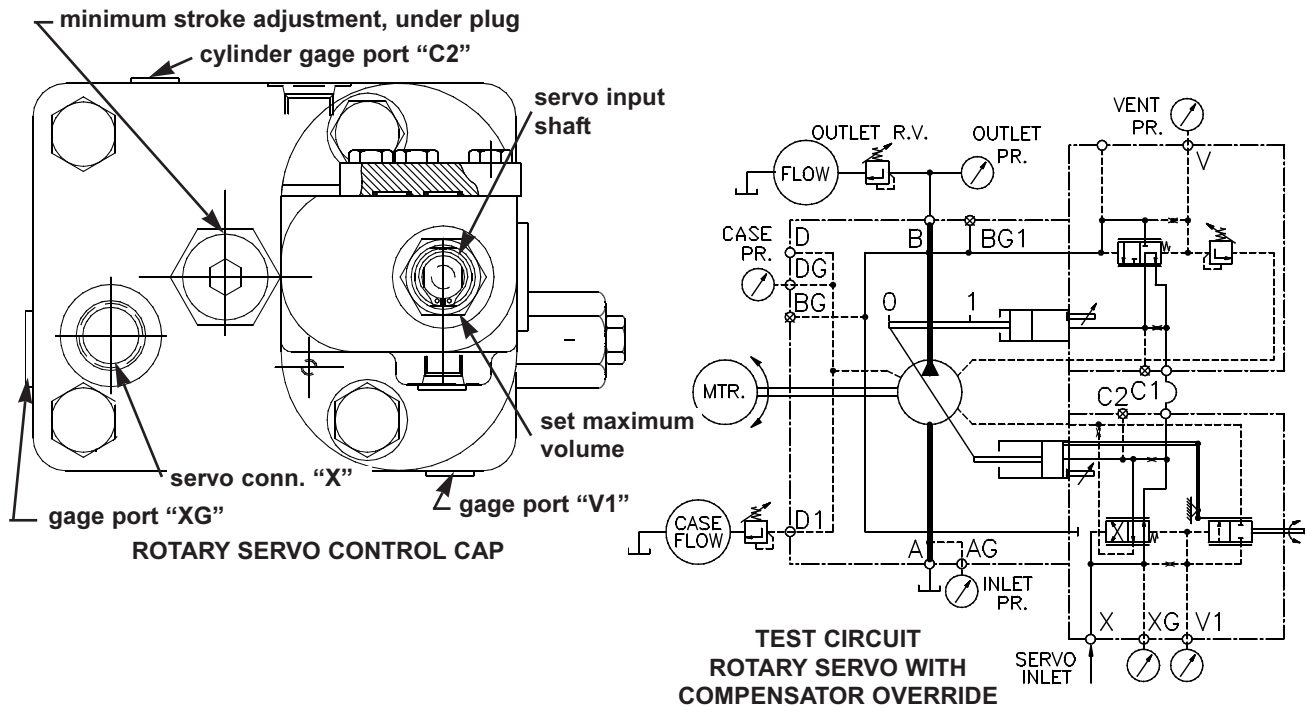

ROTARY SERVO TEST (continued)

Plumb servo supply (5 gpm, 19 lpm minimum at 700 psi +/- 30 psi, 48 bar +/- 2 bar) to control port "X".

Thread minimum displacement adjustment so that pump is on stroke.

Install gages on servo pressure gage port XG and on gage port V1, capable of measuring pressure difference to 10 psi, 0,69 bar. Gages must be adequate for servo pressure.

Start pump. Adjust rotary servo shaft till pump is at some displacement between zero and full. The difference in pressure readings between port XG and V1 should be 250, 17,2 bar +/- 30 psi, 2 bar.. Remove gages and plug gage ports.

With rotary servo shaft rotated fully clockwise, adjust maximum volume adjustment on servo until output flow is at the full displacement position. Lock in place.

Fully rotate servo shaft counter-clockwise. Pump flow should go towards zero displacement. Back out minimum volume stop until pump is at zero displacement. Lock in place.

Rotate shaft clockwise and counterclockwise at various outlet pressures. Pump displacement should follow shaft rotation between full and zero displacement smoothly and proportionally. Full to zero or zero to full displacement should be achieved in no more than .3 second.

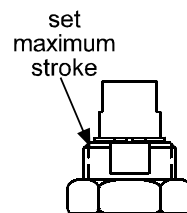

Proceed to **COMPENSATOR TEST (pg. 66)**, **TORQUE LIMITER TEST (pg. 70)**, or **FINAL PUMP TEST (pg. 75)**, as applicable.

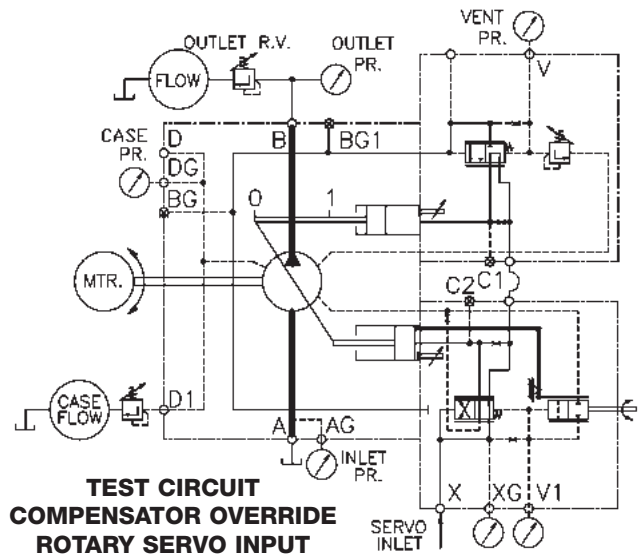
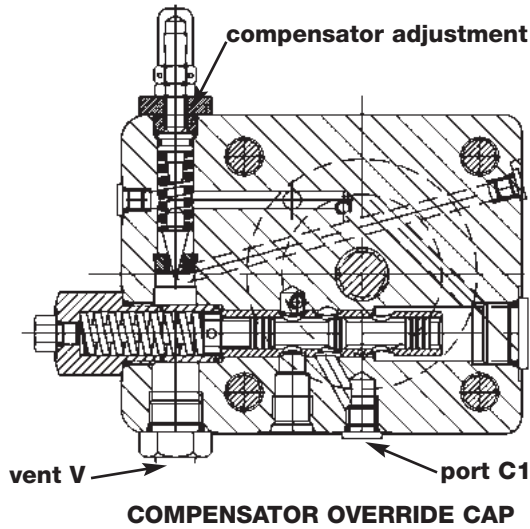

COMPENSATOR TEST

Outlet relief valve should be set to minimum pressure.

If the pump contains a servo, hydraulic or electrohydraulic stroker control, test that control first, (pg. 60, 64 or 65) then set the control to give full stroke on the pump.

Install gages on outlet pressure and V capable of measuring pressure difference to 10 psi (0.69 bar). Gages must be adequate for outlet pressure.

If testing pump with load sensing compensator or torque limiter control, the test stand must include a gage on the line from LS capable of measuring pressure difference to 10 psi (0.69 bar) and the other components shown in the load sensing test circuit. Open speed control valve fully, and close load valve to first test the compensator function.

Turn compensator adjustment screw CCW until there is no contact with spring, then adjust 1/2 turn CW after contact is made with spring.

Start prime mover. Observe for correct rotation. Pump should be at full displacement at minimum pressure.

Adjust outlet relief valve until compensator destrokes pump to zero displacement. Compensator pressure should be approximately 1000 psi (69 bar) with the 1/2 turn pre-adjustment. Note: With servo type controls, minimum compensator override pressure will be higher, depending on the servo supply pressure. See chart below.

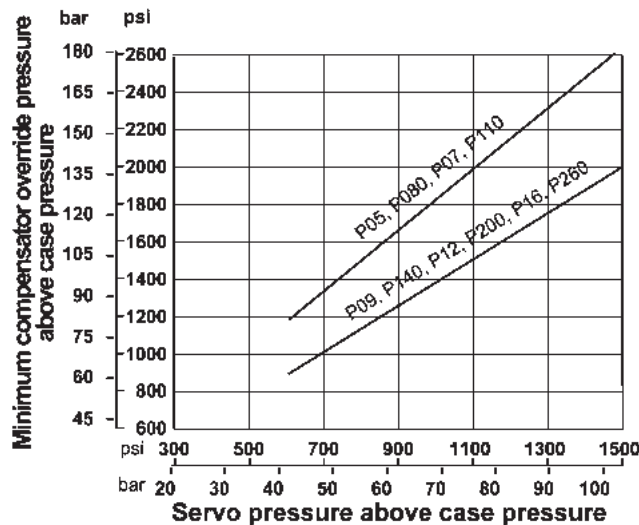

Raise compensator from minimum to maximum outlet pressure. At each condition, increase the outlet pressure until the pump fully de-strokes. At no time should the outlet pressure vary over 150 psi (10.3 bar) from the compensator setting. The control should be steady and stable at all conditions.

Calculate compensator leakage by subtracting leakage flow at full flow from leakage flow fully compensated.
Compensator leakage: 5 gpm (18,9 lpm). max.

Reduce outlet pressure to 150 psi (10,3 bar) below the compensator setting. Pump should return to full stroke. Repeat two or more times. Compensator settings should be repeatable. Proceed to **FINAL PUMP TEST (pg. 71)**, or **LOAD SENSING TEST (below)** if applicable.

LOAD SENSING TEST

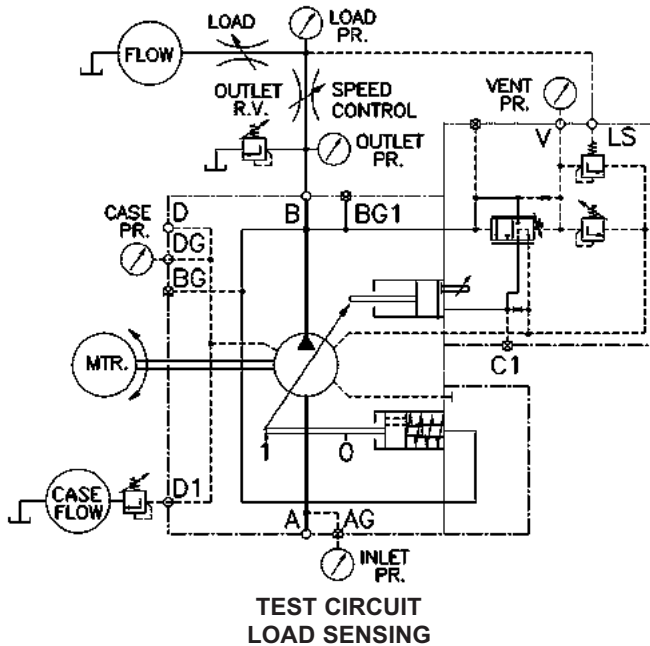

**TEST CIRCUIT
LOAD SENSING**

Caution: Load sensing control is limited to 5000 psi (345 bar) maximum pressure.

Pump should be connected to speed control valve, load sensing line and load valve as shown.

Turn the differential adjustment screw in till spring goes solid, then back out 7 turns. Close the speed control valve. Check the pressure difference from outlet pressure to load pressure. Using the differential adjustment, set this pressure difference to 275 psi ± 30 psi (19 ± 2 bar) or shop order requirement. For "M" control options, set this pressure difference to 425 psi ± 30 psi (29 ± 2 bar) or sales order requirement.

Caution: Too low or too high a setting will cause the control to malfunction. Install cap on differential adjustment.

Fully open the speed control valve. Set the compensator to 3000 psi (207 bar), and 5000 psi (345 bar). [One turn of adjustment equals approximately 2000 psi (138 bar.)] At each condition, increase the outlet pressure by closing the load valve until the pump fully de-strokes. At no time should the outlet pressure vary more than 150 psi (10,3 bar) from the compensator setting. The control should be steady and stable at all conditions.

With pump at full flow and 5000 psi (345 bar) outlet pressure, close speed control valve till flow reduces slightly. Note flow. Open load valve slowly, to drop outlet pressure toward minimum. Flow shall remain constant within 2 gpm (7,6 lpm) at all pressures.

Adjust the speed control valve till flow is at a low value. Note flow. Raise and lower outlet pressure by closing and opening the load valve. Flow shall remain constant within 2 gpm (7.6 lpm). Proceed to **FINAL PUMP TEST (pg. 71)**.

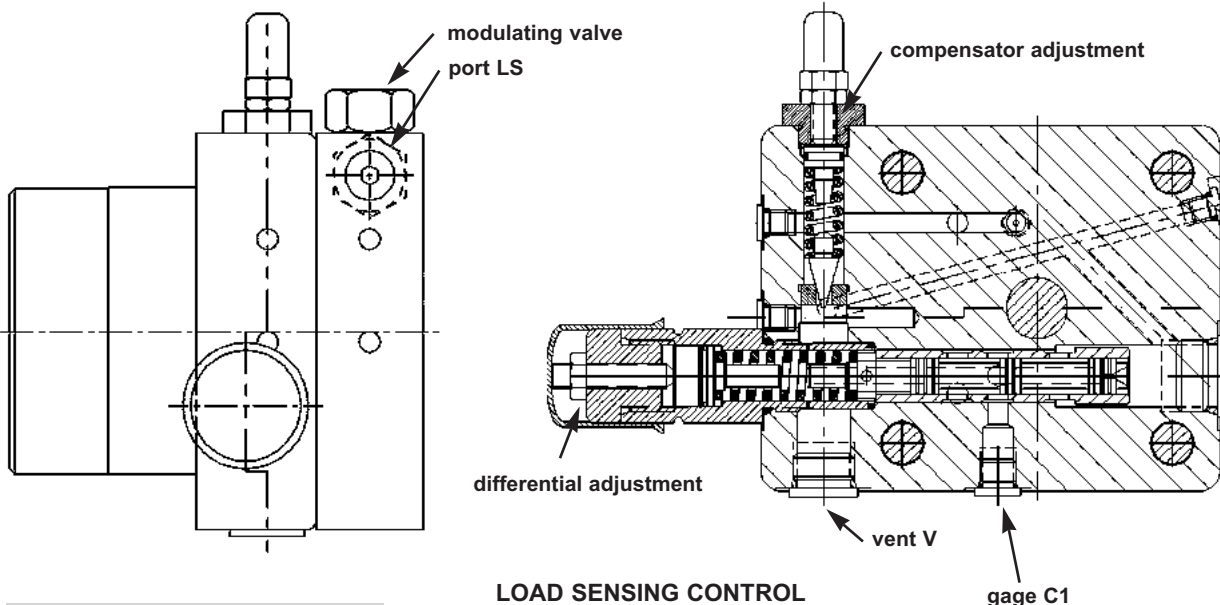

LOAD SENSING CONTROL

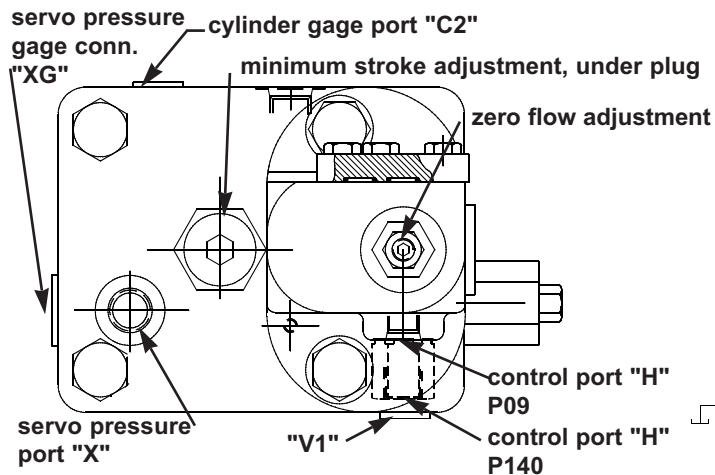

HYDRAULIC STROKER CAP

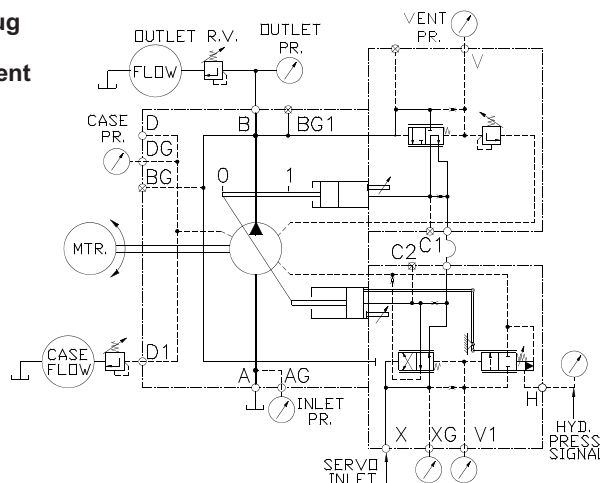

TEST CIRCUIT
HYDRAULIC STROKER
COMPENSATOR OVERRIDE

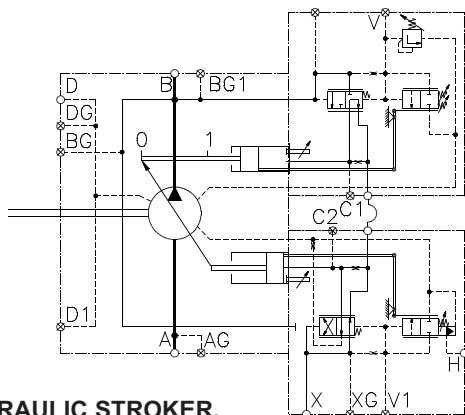

HYDRAULIC STROKER,
TORQUE LIMITER OVERRIDE

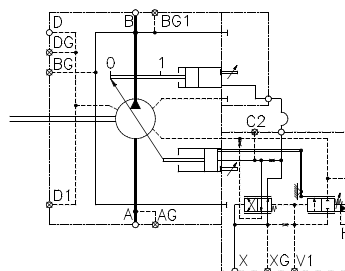

HYDRAULIC STROKER

HYDRAULIC STROKER TEST

Before testing hydraulic stroker, disable the compensator or torque limiter override, if applicable, by turning the compensator adjustment in three turns past initial contact with spring. (See compensator or torque limiter test). **CAUTION:** System must contain a relief valve to limit outlet pressure. Outlet relief valve should be set to minimum pressure.

Plumb servo supply (5 gpm, 19 lpm minimum at 700 psi +/- 30 psi, 48 bar +/- 2 bar) to control port "X". Plumb adjustable hydraulic pressure (50 to 350 psi, 3,45 to 24 bar) to control port "H".

Thread minimum stroke adjustment screw so that pump is on stroke.

Install gages on servo pressure gage port XG and on gage port V1, capable of measuring pressure difference to 10 psi, 0,69 bar. Gages must be adequate for servo pressure.

Start pump. Apply hydraulic control signal to port "H" till pump is at some stroke between zero and full. The difference in pressure readings between port XG and V1 should be 250 psi, 17,2 bar +/- 30 psi, 2 bar.

Set signal pressure to 50 psi, 3,45 bar. Back out zero volume stop and set zero flow adjustment until pump is at zero stroke. Lock both adjustments in place.

Slowly increase and decrease signal pressure between 0 and 300 psi, 20,7 bar several times at minimum and maximum operating outlet pressure. Pump stroke should follow control pressure smoothly and proportionally. Rapidly adjust signal pressure between 0 and 300 psi, 20,7 bar. Full to zero or zero to full stroke should be achieved in no more than 0,3 second.

Proceed to **COMPENSATOR TEST (pg. 66)**, **TORQUE LIMITER TEST (pg. 70)**, or **FINAL PUMP TEST (pg. 75)**, as applicable.

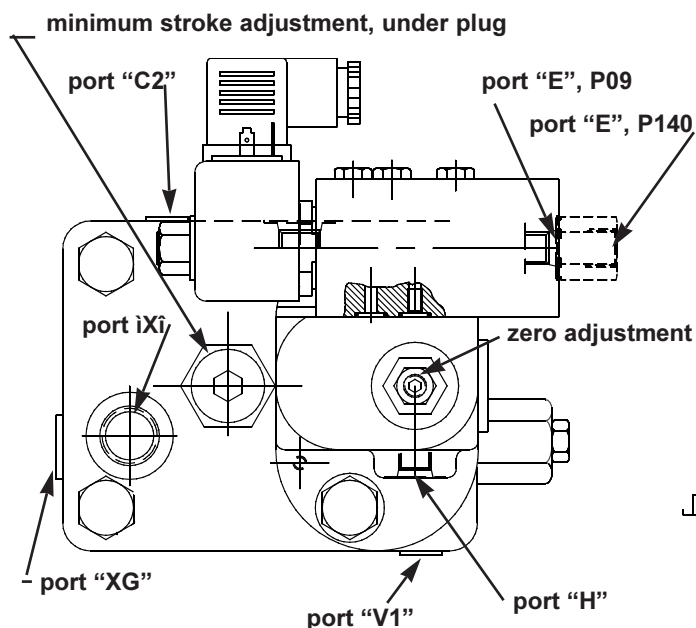

ELECTROHYDRAULIC STROKER CAP

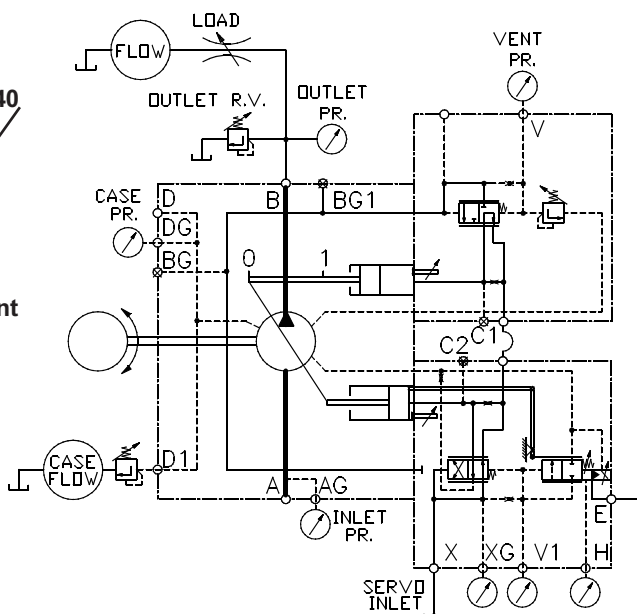

**TEST CIRCUIT
ELECTROHYDRAULIC STROKER
COMPENSATOR OVERRIDE**

ELECTROHYDRAULIC STROKER TEST

Before testing electrohydraulic stroker, disable the compensator or torque limiter override, if applicable, by turning the compensator differential adjustment fully in. (See compensator or torque limiter test) **CAUTION:** System must contain a relief valve to limit outlet pressure. Outlet relief valve should be set to minimum pressure.

Plumb servo supply (5 gpm, 19 lpm minimum at 700 psi +/- 30 psi, 48 bar +/- 2 bar) to control port "X", and to the electric stroker port, "E"

Install gages on servo pressure gage port XG and on gage port V1, capable of measuring pressure difference to 10 psi, 0,69 bar. Gages must be adequate for servo pressure.

Thread zero volume stop screw so that pump is on stroke.

Start pump. Observe for correct rotation. Adjust current to proportional valve till pump is at some stroke between zero and full. The difference in pressure readings between port XG and V1 should be 250 psi, 17,2 bar +/- 30 psi, 2 bar.

Adjust current to 175 mA. Back out zero volume stop and set zero flow adjustment until pump is at zero stroke. Lock both adjustments in place. If pump fails to respond, measure pressure at port "H", pressure to be 50 psi, 3,45 bar minimum, for 175 mA current with 24 V. coil. Remove gage after checking, to avoid unstable operation.

Increase current to 300 mA. Pump should go to full stroke. Set max. volume screw on opposite control cap for full stroke.

Increase and decrease the amperage between 0 and 300 mA several times at minimum to maximum outlet pressure. Pump stroke should follow amperage smoothly and proportionally. Full to zero or zero to full stroke should be achieved in .3 second. Adjust amperage up to 250 mA from zero stroke, then adjust down from full stroke to 250 mA. The flows at the two 250 mA settings shall not vary more than 2 gpm, 7,6 lpm from each other.

Proceed to **COMPENSATOR TEST** (pg. 66), **TORQUE LIMITER TEST** (pg. 70), or **FINAL PUMP TEST** (pg. 75), as applicable.

TORQUE LIMITER AND TORQUE LIMITER OVERRIDE TEST

The torque limiter design is a compensator with a means of varying pump stroke with pressure in this manner: The compensator vent port applies pressure to a pin. The pin moves against two independently adjustable springs. A sleeve, sliding over the pin, opens or closes the vent passage, to control the compensator pressure. The sleeve is connected through a linkage to the control piston. As pressure increases, the stroke must reduce, and vice versa, to provide approximate constant torque.

Install gages on outlet pressure and "V" capable of measuring pressure difference to 10 psi, 0,69 bar. Gages must be adequate for outlet pressure.

Turn compensator adjustment screw out to remove spring load, then 1/2 turn in.

If the pump contains a servo, hydraulic or electrohydraulic stroker control, test that control first (pg. 64, 68 or 69) then set the control to give full stroke on the pump. **CAUTION:** System must contain a relief valve to limit outlet pressure. Outlet relief valve should be set at 500 psi, 34,5 bar.

To test and set compensator function, disable torque limiter in this manner: Back out high pressure flow adjustment screw (inner) to remove all load. Turn in high flow pressure adjustment screw (outer) to go solid. Caution! do not apply over 10 in. *lb, 1,2 Nm torque to avoid damage to internal parts!

Start prime mover with outlet relief set at 500 psi, 34,5 bar. Apply a load to the pump.

Pump should be at full displacement at 500 psi, 34,5 bar.

Increase outlet pressure until compensator de-strokes pump to zero displacement. Note minimum compensated pressure versus servo pressure in chart on page 66. Set compensator to minimum compensated pressure.

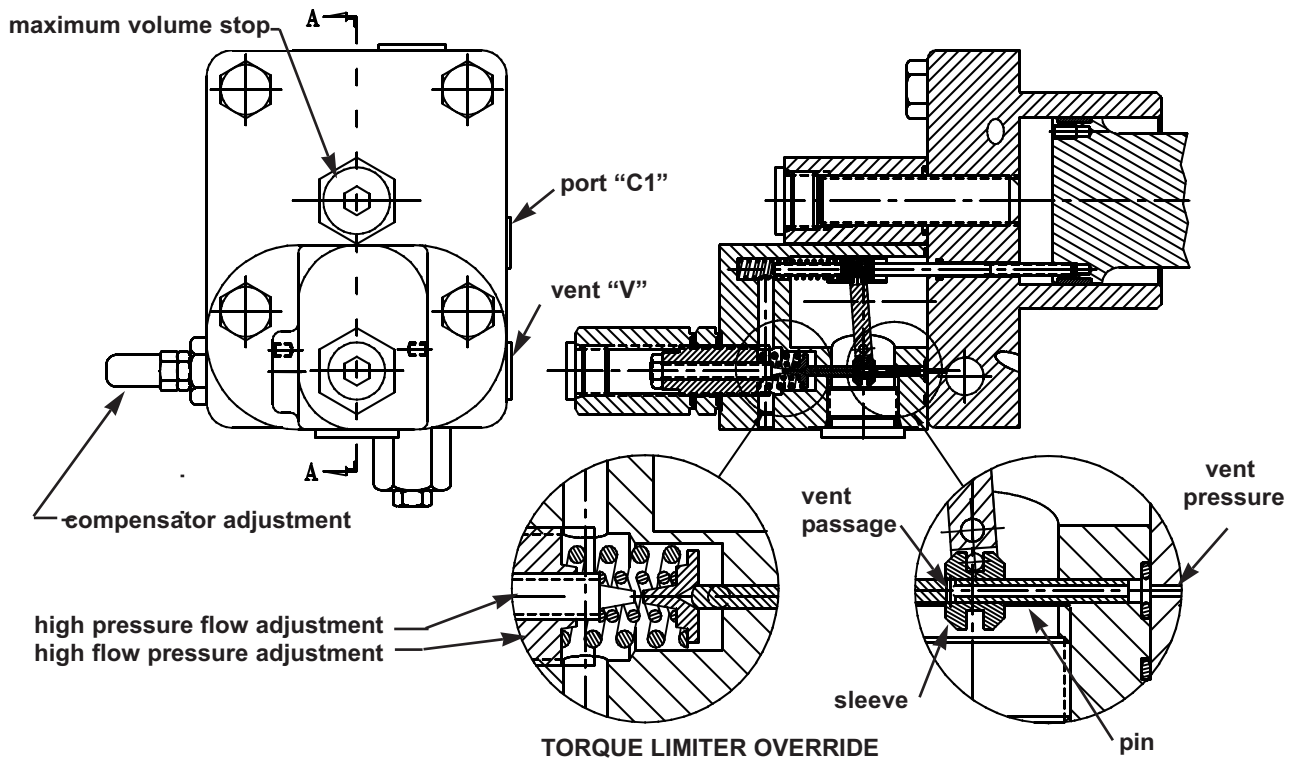
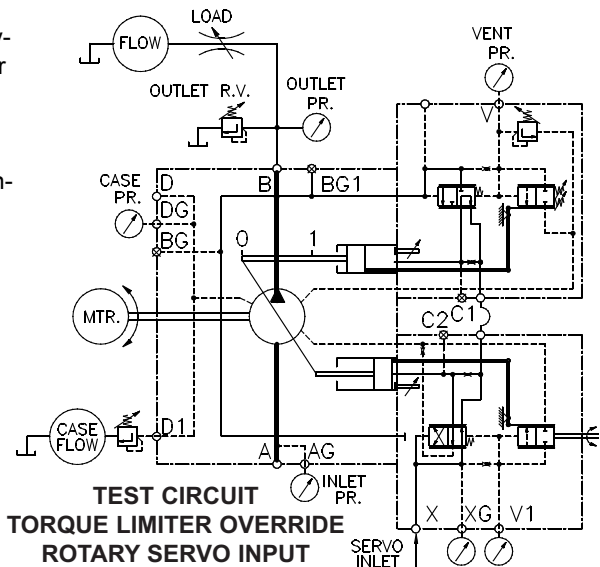

Set the compensator to 3000 psi, 207 bar, 6000 psi, 414 bar, and 7250 psi, 500 bar. (One turn approximately equals 2000 psi, 138 bar)

At each condition, increase the outlet pressure until the pump fully de-strokes. At no time should the outlet pressure vary more than 150 psi, 10,3 bar from the compensator setting. The control should be steady and stable at all conditions.

Reduce outlet pressure below the compensator setting. Pump should return to full stroke. Repeat two or more times. Compensator setting should be repeatable.

Set compensator adjustment to at least 500 psi, 34,5 bar above the maximum outlet pressure.

TORQUE LIMITER TEST AND ADJUSTMENT

Set the torque limiter by using the formula:

$$HP = P \cdot Q / (\text{Eff.} \cdot 1714), \text{ or } P = HP(\text{Eff.} \cdot 1714) / Q, \text{ or } Q = HP(\text{Eff.} \cdot 1714) / P$$

where P = Pressure in psi

Q = flow in GPM

Eff. = overall efficiency

$$\text{or } kW = P \cdot Q / (\text{Eff.} \cdot 600), \text{ or } P = kW(\text{Eff.} \cdot 600) / Q, \text{ or } Q = kW(\text{Eff.} \cdot 600) / P$$

where P = pressure in Bar

Q = flow in lpm

Eff. = overall efficiency

calculate these two values:

- a. Outlet pressure at full pump flow.
- b. Pump flow at full outlet pressure.

1. Set outlet to pressure (a) calculated above. Back out high pressure flow adjusting screw (inner screw) to remove all load. Set the high flow pressure adjusting screw (outer) so that pump just commences to de-stroke.

2. Set the system to the required maximum outlet pressure. Set high pressure flow adjusting screw (inner) to obtain the calculated flow (b) at full outlet pressure.

Note: Electric motor current or engine load may be used instead of calculated flows to set power. In step 1, set the high flow adjustment to achieve the rated motor current or engine load. In step 2, set the high pressure adjustment to achieve the rated motor current or engine load.

Proceed to **FINAL PUMP TEST (pg. 75)**

LOAD SENSING TORQUE LIMITER

Caution: Load sensing control is limited to 5000 psi, 345 bar maximum pressure.

Pump should be connected to speed control valve, load sensing line and load valve as shown.

Install gages on outlet pressure and "V" capable of measuring pressure difference to 10 psi, 0,69 bar. Gages must be adequate for outlet pressure.

Turn compensator adjustment screw out to remove spring load, then 1/2 turn in. Turn the differential adjustment screw in till spring goes solid, then back out 7 turns.

To test and set compensator and load sensing function, disable torque limiter in this manner: Back out high pressure flow adjustment screw (inner) to remove all load. Turn in high flow pressure adjustment screw (outer) to go solid. Caution! do not apply over 10 in. •lb, 1,2 Nm torque to avoid damage to internal parts!

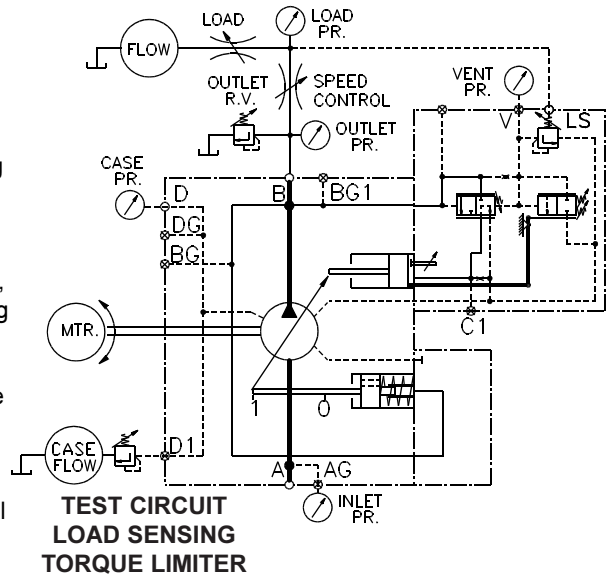

**TEST CIRCUIT
LOAD SENSING
TORQUE LIMITER**

Start prime mover with outlet relief set at 500 psi, 34,5 bar. Apply a load to the pump.

Pump should be at full displacement at 500 psi, 34,5 bar.

Increase outlet pressure until compensator de-strokes pump to zero displacement. Note minimum compensated pressure versus servo pressure in chart on page 58. Set compensator to minimum compensated pressure.

Close the speed control valve. Check the pressure difference from outlet pressure to load pressure. Using the differential adjustment, set this pressure difference to 275 psi ± 30 psi, 29 ± 2 bar or shop order requirement. Caution: Too low or too high a setting will cause the control to malfunction. Install cap on differential adjustment.

Fully open the speed control valve. Set the compensator to 3000 psi, 207 bar, and 5000 psi, 345 bar. (One turn of adjustment equals approximately 2000 psi, 138 bar.) At each condition, increase the outlet pressure by closing the load valve until the pump fully de-strokes. At no time should the outlet pressure vary more than 150 psi, 10,3 bar from the compensator setting. The control should be steady and stable at all conditions.

With pump at full flow and 5000 psi, 345 bar outlet pressure, close speed control valve till flow reduces slightly. Note flow. Open load valve slowly, to drop outlet pressure toward minimum. Flow shall remain constant within 2 gpm, 7,6 lpm at all pressures.

Adjust the speed control valve till flow is at a low value. Note flow. Raise and lower outlet pressure by closing and opening the load valve. Flow shall remain constant within 2 gpm, 7,6 lpm.

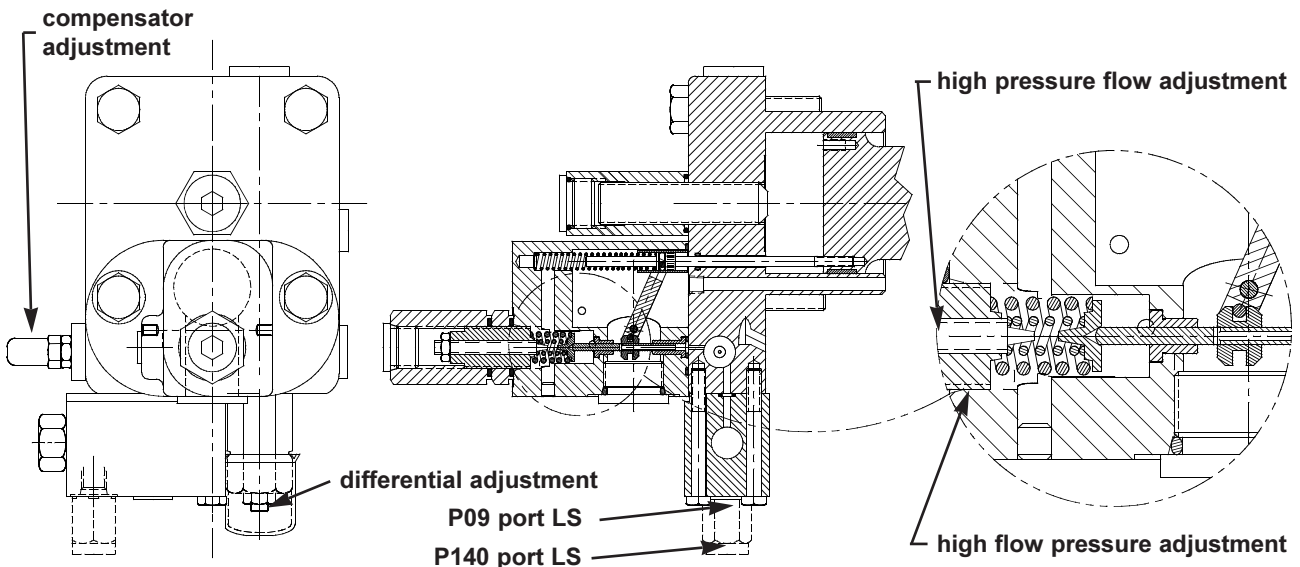

Fully open the speed control valve.

Set the torque limiter by using the formula:

$$HP = P \cdot Q / (\text{Eff.} \cdot 1714), \text{ or } P = HP(\text{Eff.} \cdot 1714) / Q, \text{ or } Q = HP(\text{Eff.} \cdot 1714) / P$$

where P = Pressure in psi

Q = flow in GPM

Eff. = overall efficiency

$$\text{or } kW = P \cdot Q / (\text{Eff.} \cdot 600), \text{ or } P = kW(\text{Eff.} \cdot 600) / Q, \text{ or } Q = kW(\text{Eff.} \cdot 600) / P$$

where P = pressure in Bar

Q = flow in lpm

Eff. = overall efficiency

calculate these two values:

- a. Outlet pressure at full pump flow.
- b. Pump flow at full outlet pressure.

1. Set outlet pressure (a) calculated above. Back out high pressure flow adjusting screw (inner screw) to remove all load. Set the high flow pressure adjusting screw (outer) so that pump just commences to de-stroke.
2. Set the system to the required maximum outlet pressure. Set high pressure flow adjusting screw (inner) to obtain the calculated flow (b) at full outlet pressure.

Note: Electric motor current or engine load may be used instead of calculated flows to set power. In step 1, set the high flow adjustment to achieve the rated motor current or engine load. In step 2, set the high pressure adjustment to achieve the rated motor current or engine load.

Proceed to **FINAL PUMP TEST (pg. 75)**

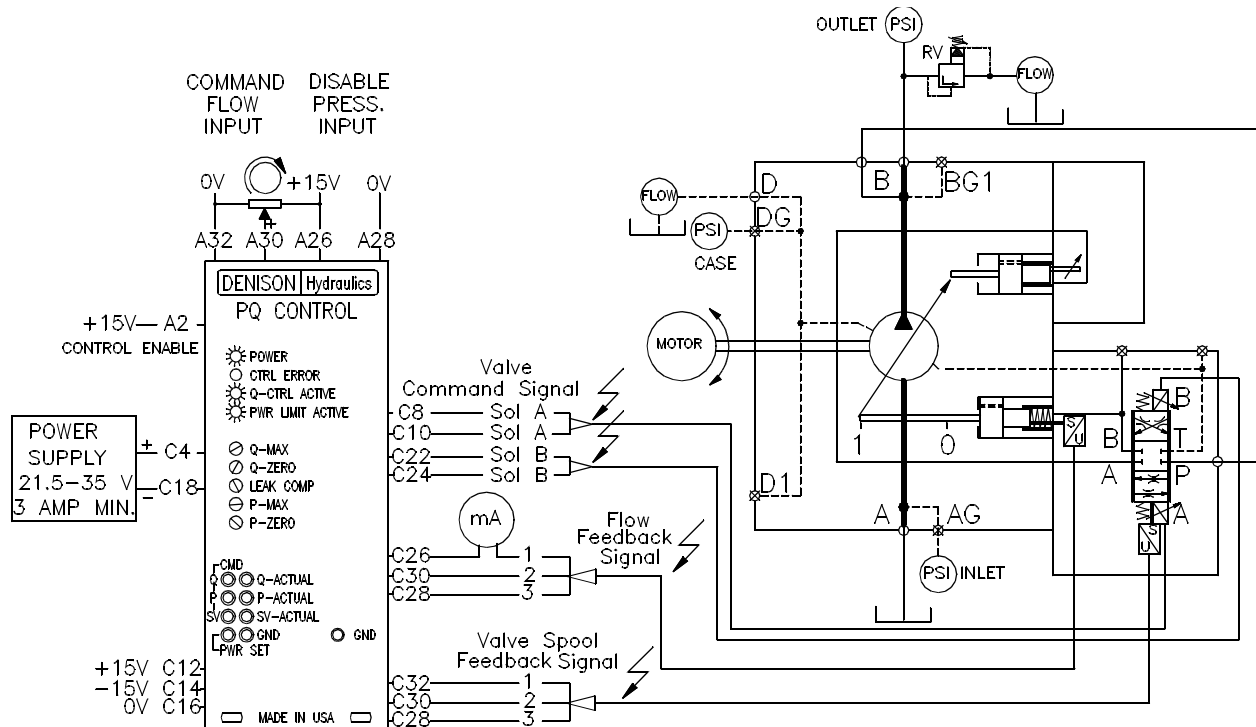

PRESSURE/FLOW (PQ) CONTROL

Connect PQ control driver card 020-14133 to pump as indicated.

1. Adjust maximum volume stop to full displacement by backing off screw CCW until there is no contact with control piston.
2. Set test stand relief valve at 500 psi. Jog electric motor to verify correct rotation. Start electric motor. With power off to the control, pump should be at full displacement at 500 psi, about 66 gpm.
3. Apply power to control. With command pot at 0 volts, the pump should go to zero displacement, at approximately 300 psi.
4. Check mA reading of flow feedback signal. At zero displacement, flow feedback signal shall be 6.67 mA +/- 0.2 mA. If incorrect, adjust left side screw on rear of flow feedback lvdt until output is within range.
5. Rotate command from 0 to 10 volts to 0 volts. Pump shall stroke from zero to full stroke to zero stroke as signal goes from 0 to 10 to 0 volts. Proceed to **Final Pump Test, (pg. 75)**.

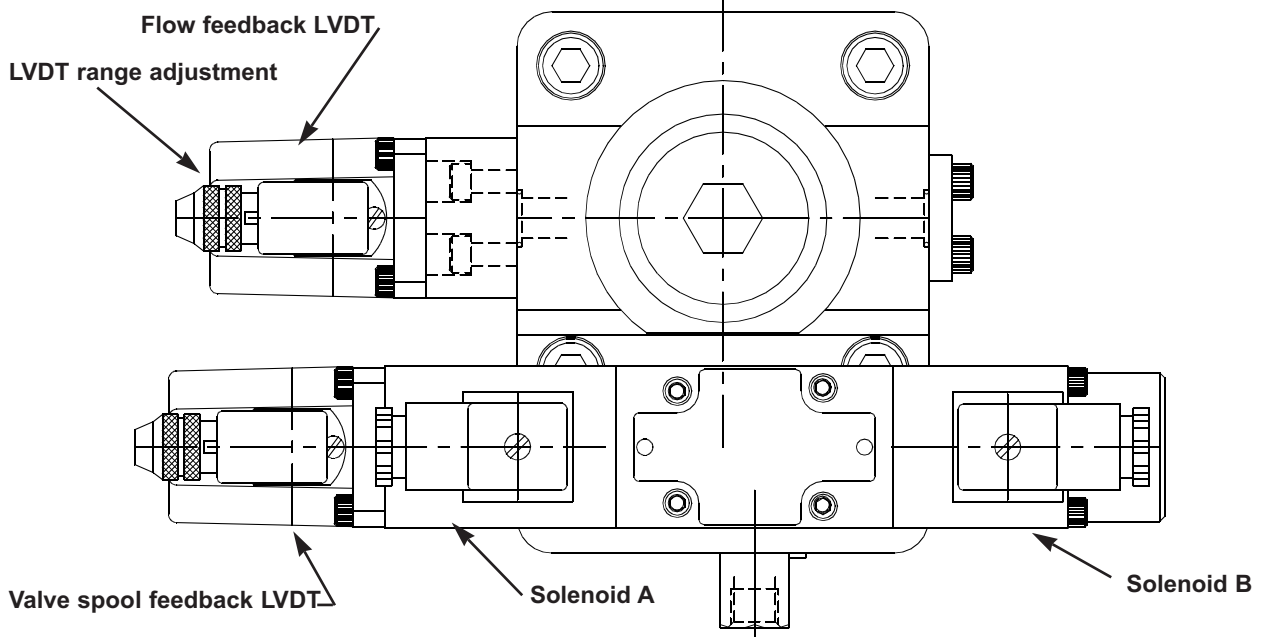

FINAL PUMP TEST

Operate the pump with the following outlet pressures for the times indicated.

3000 psi ± 100 psi, 207 bar ± 6,9 bar	2 minutes minimum
5000 psi ± 100 psi, 345 bar ± 6,9 bar	1 minute minimum
6000 psi ± 100 psi, 414 bar ± 6,9 bar	1 minute minimum

While breaking in, destroke the pump several times at each pressure setting, by either reducing compensator setting, or the servo/stroker command.

PUMP SERIES	FULL STROKE REQUIREMENTS AT 6000 PSI, 414 BAR			
	MINIMUM OUTPUT FLOW		MAX CASE DRAIN FLOW	
	GPM	LPM	GPM	LPM
P09/P140 @ 1750 RPM	61.0	231	5.2	19,7
P09/P140 @ 1450 RPM	50.0	189	5.2	19,7

Raise compensator setting from minimum to maximum outlet pressure. **Caution:** Load sensing control is limited to 5000 psi, 345 bar maximum pressure.

At each condition, increase the outlet pressure until the pump fully de-strokes. At no time should the outlet pressure vary over 150 psi, 10,3 bar from full to zero flow. The control should be steady and stable at all conditions.

Reduce outlet pressure to 150 psi, 10,3 bar below the compensator setting. Pump should return to full stroke. Repeat two or more times. Compensator settings should be repeatable. Set compensator at 1000 psi ± 100 psi, 69 bar ± 6,9 bar standard, or desired value.

Check for leaks. NO external leaks are permitted. The shaft seal can be dry or damp. (Damp: A very small amount of oil at the seal and shaft joint, but NOT running onto the seal face).

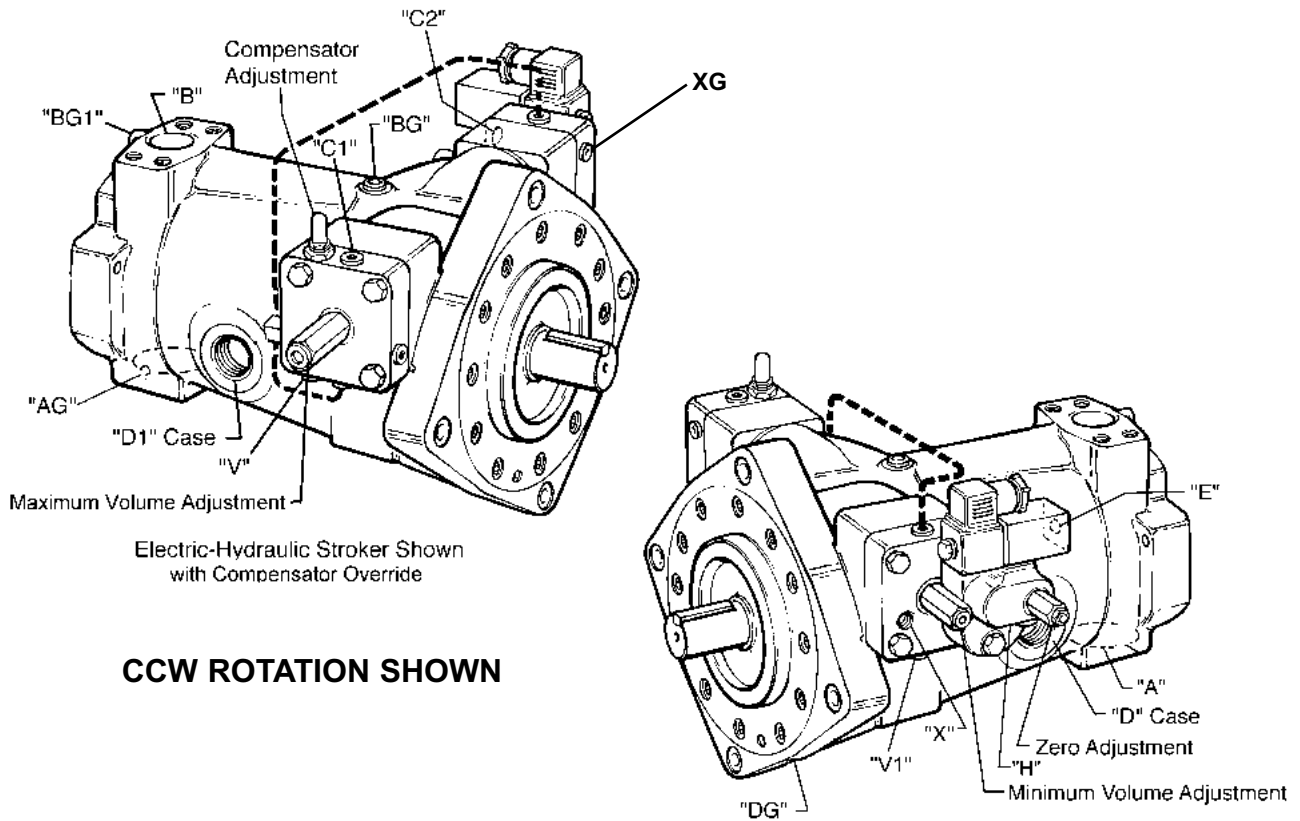

FLUID CONNECTIONS

DESCRIPTION	P09	P140
PORT AINLET	3.5" SAE CODE 61 5/8-11 SCREWS	3.5" SAE CODE 61 M16-2 SCREWS
PORT BSYSTEM	1-1/2 SAE CODE 62 5/8-11 SCREWS	1-1/2 SAE CODE 62 M16-2 SCREWS
PORT C1OFF-STROKE CYLINDER GAGE	SAE-4	1/4 BSPP
PORT C2ON-STROKE CYLINDER GAGE	SAE-4	1/4 BSPP
PORT DCASE DRAIN	SAE-24	1-1/2 BSPP
PORT D1CASE DRAIN	SAE-24	1-1/2 BSPP
PORT DG.....DRAIN GAGE, AIR BLEED PORT	SAE-4	1/4 BSPP
PORT AG.....INLET GAGE	SAE-4	1/4 BSPP
PORT BG.....SYSTEM GAGE	SAE-6	1/4 BSPP
PORT BG1...ALTERNATE SYSTEM GAGE	SAE-6	1/4 BSPP
PORT EELECTROHYDRAULIC STROKER SERVO SUPPLY	SAE-4	1/4 BSPP
PORT HHYDRAULIC STROKER SIGNAL	SAE-4	1/4 BSPP
PORT LSLOAD SENSING LINE (SEE PAGE 4)	SAE-4	1/4 BSPP
PORT VCOMPENSATOR, TORQUE LIMITER, LOAD SENSING VENT	SAE-8	3/8 BSPP
PORT V1SERVO VENT	SAE-4	1/4 BSPP
PORT XSERVO SUPPLY	SAE-8	3/8 BSPP
PORT XG.....SERVO GAGE	SAE-10	1/2 BSPP

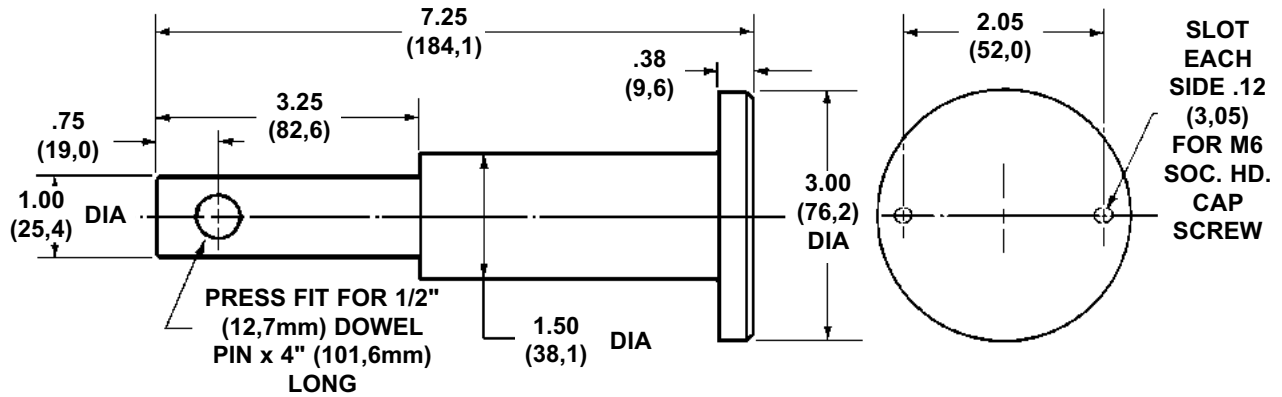

T-1
(Lifting tool)
 Barrel & inner race assembly

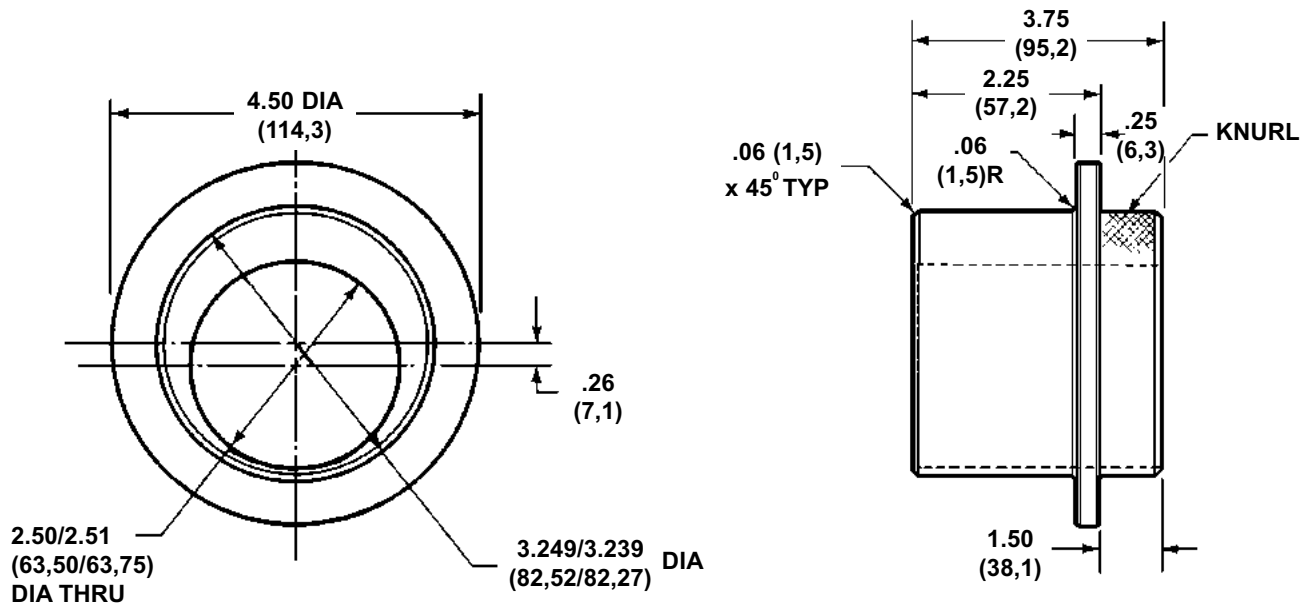

T-2
(Positioning tool)
 For positioning the stroking piston
 during cam installation
 (2 required)

T-3

(Installation tool)

Retainer & shaft bearing In cradle

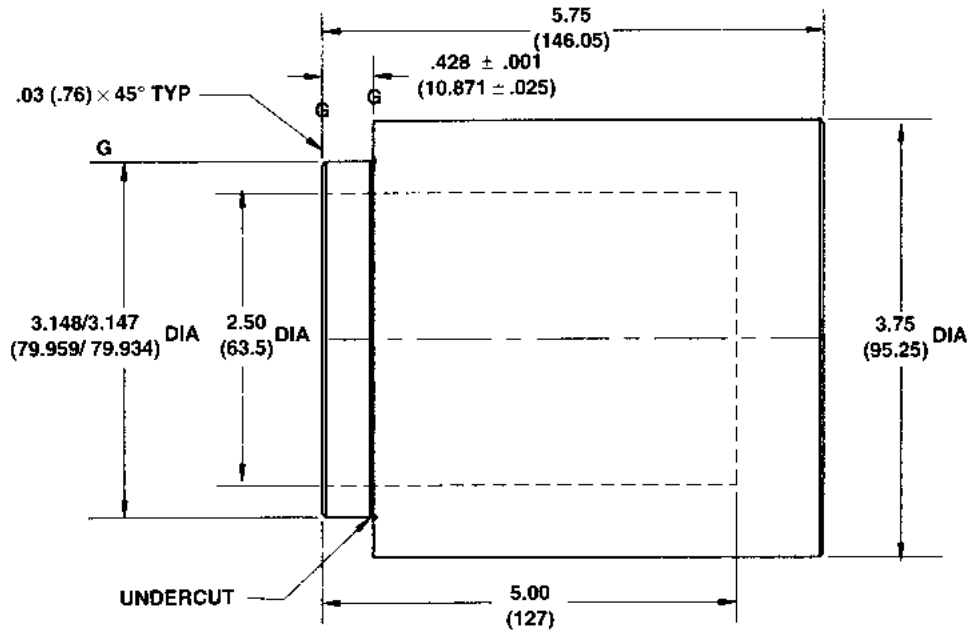

T-4

(Installation tool)

Shaft seal over shaft

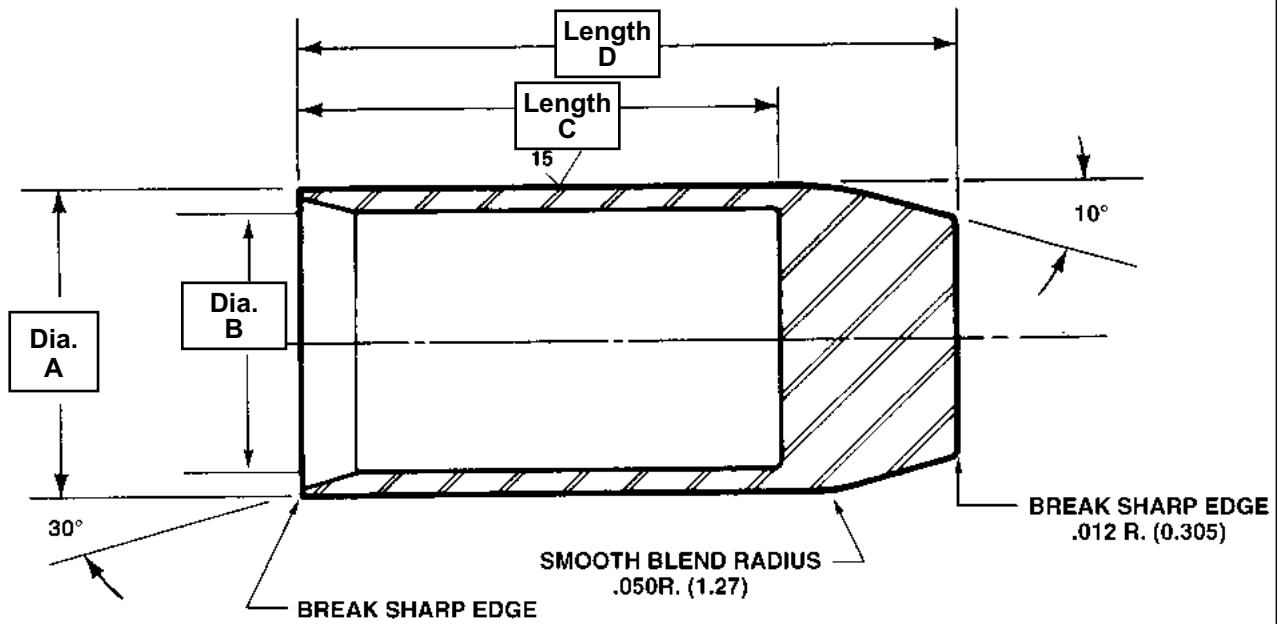

Shaft	A		B		C		D	
	in.	mm	in.	mm	in.	mm	in.	mm
P09 keyed	1.878/1.880	47,70/47,75	1.755/1.760	44,58/44,70	3.00	76,2	4.50	114,3
P09 splined	1.878/1.880	47,70/47,75	1.725/1.730	43,82/43,94	3.00	76,2	4.50	114,3
P140	2.130/2.135	54,10/54,23	1.974/1.976	50,14/50,19	3.63	92,2	5.13	130,3

TYPICAL CHARACTERISTICS

Specification	Term	P09	P140
• displacement at max. angle	in³/rev.	8.6	8.6
	cm³/rev	140,9	140,9
• pressure continuous	psi	6000	6000
	bar	420	420
• pressure intermittent (not to exceed 6 sec./minute)	psi	7250	7250
	bar	500	500
• speed, @ atmospheric inlet	rpm	2300	2300
max. with boost	rpm	2800	2800
• rotating inertia	lbs/in²	152	152
	kg.m²	0.044	0.044
• compensator response off-stroke	sec.	0.06	0.06
on-stroke	sec.	0,11	0,11
• compensator adjustment.....	psi/turn	2000	2000
	bar/turn	138	138
• minimum compensating pressure (comp, torque limiter)	psi	250	250
	bar	17,2	17,2
• minimum compensating pressure (override controls) (at 700 psi, 48,3 bar servo)	psi	1050*	1050*
• typ. servo & stoker response @ 700 psi, 48,3 bar servo	bar	93*	93*
pressure, zero to full stroke and vice versa	sec.	<0.35	<0,35
• servo flow required for this response	gpm	5	5
	l/min	19	19
• minimum servo pressure.....	psi	700	700
	bar	48	48
• maximum servo pressure	psi	1500	1500
	bar	103	103
• electric stoker nominal coil resistance (24v. coil)	ohms	41	41
• electric stoker nominal coil resistance (12v. coil)	ohms	10	10
• handwheel turns, full to zero stroke	turns	8.1	8.1
• torque to turn handwheel @ 1000 psi., 70 bar	in-lbs	125	125
	Nm	15	15
• torque to turn handwheel @ 7250 psi., 500 bar	in-lbs	275	275
	Nm	32	32
• rotary servo shaft rotation, 0 to full stroke	degrees	52-57	52-57
• torque to turn rotary servo shaft	in-lbs	20	20
	Nm	2,3	2,3
• maximum/minimum case pressure (continuous)	psi	25/3	25/3
	bar	1,7/0,2	1,7/0,2
• maximum/minimum case pressure (intermittent)	psi	50/3	50/3
	bar	3,4/0,2	3,4/0,2
• input mounting-4 bolt flange	SAE	152-4 (D)	
	ISO 3019/2		180 B4HW
• input shaft, keyed	SAE	44-1 (D)	
• input shaft, splined	SAE	44-4 (D)	
• input shaft, keyed ISO 3019/2	ISO		G50N
• input shaft, splined ISO 3019/2.....	ISO		K50N
• input shaft, keyed DIN	DIN		6885 50 mm
• input shaft, splined DIN.....	DIN		5480-50 mm
• weight	pounds	220	220
	kg.	100	100

*plus case pressure

GENERAL

The **DENISON HYDRAULICS** P09/P140 Series is a variable displacement open circuit axial piston pump with advance pumping and control concepts.

MOUNTING

This pump is designed to operate in any position. The pump shaft must be in alignment with the shaft of the prime mover and should be checked with a dial indicator. The mounting pad or adapter into which the pump pilots must be concentric with the pump shaft to prevent bearing failure. This concentricity is particularly important if the shaft is rigidly connected to the driven load without a flexible coupling.

SHAFT INFORMATION

Splined: The shafts will accept a maximum misalignment of .006", 0.15 mm TIR. Angular misalignment at the male and female spline axis must be less than 0.001 in. per in. radius, 0.001 mm per mm. The coupling interface must be lubricated. DENISON HYDRAULICS recommends lithium molydisulfide or similar grease. The female coupling should be hardened to 27-34 Rc. The P09 must conform to SAE J498B (1971) class 1 flat root side fit, the P140 must conform to either ISO 4156 fillet root side fit module 2,50 or DIN 5480 (9H) flat root side fit module 2.00 as applicable

Keyed: High strength heat treated keys must be used. Replacement keys must be hardened to 27-34 Rc. The key corners must be chamfered .030"-.040", 0.75-1.00 mm at 45° to clear radii that exist in the keyway.

PORTING INFORMATION

See port identification section for port locations and sizes.

The maximum case pressure is 25 psi, 1.7 bar continuous, 50 psi, 3.4 bar intermittent. Case pressures must never exceed inlet pressure by more than 25 psi, 1.7 bar. When connecting case drain line make certain that drain plumbing passes above highest point of the pump before returning to the reservoir, if not, install a 5 psi, 0.3 bar case pressure check valve to be certain the case is filled with oil at all times.

The case leakage line must be of sufficient size to prevent back pressure in excess of 25 psi, 1.7 bar and returned to the reservoir below the surface of the oil as far from the supply suction as possible. All fluid lines, whether pipe, tubing, or hose must be of adequate size and strength to assure free flow through the pump. An undersize inlet line will prevent the pump from reaching full speed and torque. An undersized outlet line will create back pressure and cause improper operation. Flexible hose lines are recommended. If rigid piping is used, the workmanship must be accurate to eliminate strain on the pump port block or to the fluid connections. Sharp bends in the lines must be eliminated wherever possible. All system piping must be cleaned with solvent or equivalent before installing pump. Make sure the entire hydraulic system is free of dirt, lint, scale, or other foreign material.

CAUTION: Do not use galvanized pipe. Galvanized coating can flake off with continued use.

INLET CONDITIONS AT SEA LEVEL

SPEED	GAGE PRESSURE				ABS. PRESS.	
	psig	bar	in. hg	mm hg	psi	bar
1200	-3	-0,2	-6.1	-155	11.7	0,8
1500	-3	-0,2	-6.1	-155	11.7	0,8
1800	-3	-0,2	-6.1	-155	11.7	0,8
2300	0	0	0	0	14.7	1,01
2500	2.7	0,2	5.5	150	17.4	1,20
2800	7.1	0,5	14.5	325	21.8	1,50

NOTE: Inlet conditions apply for petroleum base fluids. Contact **DENISON HYDRAULICS** for inlet conditions with other fluids.

RECOMMENDED FLUIDS

See DENISON HYDRAULICS bulletin **SPO-AM305** for more information

MAINTENANCE

This pump is self-lubricating and preventative maintenance is limited to keeping system fluid clean by changing filters frequently. Keep all fittings and screws tight. Do not operate at pressures and speeds in excess of the recommended limit. If the pump does not operate properly, check the troubleshooting chart before attempting to overhaul the unit. Overhauling is relatively simple and may be accomplished by referring to the disassembly, rework limits of wear parts and assembly procedures.

FLUID CLEANLINESS

Fluid must be cleaned before adding to the system, and continuously during operation by filters that maintain a cleanliness level of NAS 1638 Class 8. This approximately corresponds to ISO 17/14.

CONVERSIONS & FORMULAS

DEFINITION & UNIT

<i>displacement</i>	$\text{in}^3/\text{rev} \times 16.387 = \text{cm}^3/\text{rev}$	$\text{cm}^3/\text{rev} \times 0.06102 = \text{in}^3/\text{rev}$
<i>flow</i>	$\text{gpm} \times 3.78 = \text{L}/\text{min}$	$\text{L}/\text{min} \times 0.2642 = \text{gpm}$
<i>power</i>	$\text{hp} \times 0.7457 = \text{kW}$	$\text{kW} \times 1.341 = \text{hp}$
<i>torque</i>	$\text{lb-ft} \times 1.3567 = \text{Nm}$	$\text{Nm} \times 0.7376 = \text{lb-ft}$
<i>pressure</i>	$\text{lbs}/\text{in}^2 \text{ (psi)} \times 0.06895 = \text{bar}$ $\text{lbs}/\text{in}^2 \text{ (psi)} \times 6.895 = \text{kPa}$	$\text{bar} \times 14.50 = \text{lbs}/\text{in}^2 \text{ (psi)}$ $\text{kPa} \times 0.1450 = \text{lbs}/\text{in}^2 \text{ (psi)}$
<i>weight</i>	$\text{lb} \times 0.4536 = \text{kg}$	$\text{kg} \times 2.205 = \text{lbs}$
<i>force</i>	$\text{lb} \times 4.448 = \text{N}$	$\text{N} \times 0.2248 = \text{lbs}$
<i>volume</i>	$\text{in}^3 \times 16.387 = \text{cm}^3$	$\text{cm}^3 \times 0.06102 = \text{in}^3$
<i>area</i>	$\text{in}^2 \times 6.452 = \text{cm}^2$	$\text{cm}^2 \times 0.1550 = \text{in}^2$
<i>length</i>	$\text{in} \times 25.4 = \text{mm}$	$\text{mm} \times 0.03937 = \text{in}$
<i>temperature</i>	$\frac{\text{degree F} - 32}{1.8} = \text{°C}$	$1.8 \times \text{°C} + 32 = \text{°F}$
<i>viscosity</i>	$\text{cSt} \times 1.0 = \text{mm}^2/\text{sec}$ $\text{SSU} = \text{cSt} \times 4.25 + 14$	$\text{mm}^2/\text{sec} \times 1.0 = \text{cSt}$ $20 \text{ cSt} = 99 \text{ SSU}$

FLUID POWER FORMULAS

<i>Pump input torque</i>	<i>lbs. in.</i>	$\frac{\text{pressure}(\text{psi}) \times \text{displacement} (\text{in}^3/\text{rev})}{2\pi \times \text{mech. eff.}}$
<i>Pump input power</i>	<i>hp</i>	$\frac{\text{rpm} \times (\text{in}^3/\text{rev}) \times (\text{psi})}{395934 \times \text{overall eff.}}$
<i>Pump output flow</i>	<i>U.S. gpm</i>	$\frac{\text{rpm} \times (\text{in}^3/\text{rev}) \times \text{volumetric eff.}}{231}$
<i>Fluid motor speed</i>	<i>rpm</i>	$\frac{231 \times \text{flow rate}(\text{U.S. gpm}) \times \text{volumetric eff.}}{\text{displacement} (\text{in}^3/\text{rev})}$
<i>Fluid motor torque</i>	<i>lbs. in.</i>	$\frac{\text{pressure}(\text{psi}) \times \text{displacement} (\text{in}^3/\text{rev}) \times \text{mech. eff.}}{2\pi}$
<i>Fluid motor power</i>	<i>hp</i>	$\frac{\text{rpm} \times (\text{in}^3/\text{rev}) \times (\text{psi}) \times \text{overall eff.}}{395934}$
(metric)		
<i>Pump input torque</i>	<i>Nm</i>	$\frac{\text{pressure}(\text{bar}) \times \text{displacement} (\text{cm}^3/\text{rev})}{20\pi \times \text{mech. eff.}}$
<i>Pump input power</i>	<i>kW</i>	$\frac{\text{rpm} \times (\text{cm}^3/\text{rev}) \times (\text{bar})}{600000 \times \text{overall eff.}}$
<i>Pump output flow</i>	<i>Lpm</i>	$\frac{\text{rpm} \times (\text{cm}^3/\text{rev}) \times \text{volumetric eff.}}{1000}$
<i>Fluid motor speed</i>	<i>rpm(min⁻¹) (tr/mn)</i>	$\frac{1000 \times \text{flow rate} (\text{Lpm}) \times \text{volumetric eff.}}{\text{displacement} (\text{cm}^3/\text{rev})}$
<i>Fluid motor torque</i>	<i>Nm</i>	$\frac{\text{pressure}(\text{bar}) \times \text{displacement} (\text{cm}^3/\text{rev}) \times \text{mech. eff.}}{20\pi}$
<i>Fluid motor power</i>	<i>kW</i>	$\frac{\text{rpm} \times (\text{cm}^3/\text{rev}) \times (\text{bar}) \times \text{overall eff.}}{600000}$

PUMP ORDERING CODE

Premier pumps										Model number sheet																			
Example model code:										P	16	H	-02	R	1	*	-C	0	0	-C	0								
										P																			
Pump										P																			
Displacement																													
4.9 cu.in./rev.											05																		
80.3 cc/rev.											080																		
6.7 cu.in./rev.											07																		
109.8 cc/rev.											110																		
8.6 cu.in./rev.											09																		
140.9 cc/rev.											140																		
12.2 cu.in./rev.											12																		
200.0 cc/rev.											200																		
16.0 cu.in./rev.											16																		
262.2 cc/rev.											260																		
Style																													
High speed (>1800 RPM)(for P16/260 only)											H																		
Quiet (for P16/260 only)											Q																		
All other sizes																													
Shaft																													
Keyed - SAE or ISO													-02																
Splined - SAE or ISO													-03																
Splined - SAE high torque (P16 only)													-05																
Keyed - DIN (metric pumps only) (DIN 40mm for sizes 080 & 110, DIN 50mm for sizes 140 & 200, DIN 60mm for size 260)													-06																
Splined - DIN (metric pumps only) (DIN 40mm for sizes 080 & 110, DIN 50mm for sizes 140 & 200, DIN 60mm for size 260)													-07																
Keyed - DIN (DIN 60mm for size 200 only)													-08																
Splined - DIN (DIN 60mm for size 200 only)													-09																
Rotation																													
Clockwise														R															
Counter-clockwise														L															
Seals																													
Nitrile (Buna-N)															1														
EPR (pump will be unpainted unless otherwise specified)															4														
Flourocarbon (Viton)															5														
Design letter (assigned by manufacturer)																*													
Primary controls																													
Compensator																			-C										
Load sensing compensator (50 PSI pressure drop)																				-L									
Load sensing compensator (200 PSI pressure drop)																					-M								
Rotary servo																					-R								
Hydraulic servo																					-H								
Electro-hydraulic servo																					-E								
Low torque limiter																					-J								
High torque limiter																					-K								
Load sensing (L) + low torque limiter (J)																					-V								
Load sensing (L) + high torque limiter (K)																					-W								
PQ high response																					-X								
Load sensing (M) + low torque limiter (J)																					-Y								
Load sensing (M) + high torque limiter (K)																					-Z								
Primary control options																													
Max. volume screw without indicator																					1								
Handwheel max. volume control without indicator (not available w/ R, H, E, & X primary controls)																					2								
Max. volume screw with potentiometer																						3							
Max. volume screw with LVDT																						4							
Max. volume screw with mechanical cam angle indicator																						5							
Handwheel max. volume control with potentiometer (not available w/ R, H, E, & X primary controls)																						6							
Handwheel max. volume control with LVDT (not available w/ R, H, E, & X primary controls)																						7							
Handwheel max. volume control with mechanical cam angle indicator (not available w/ R, H, E, & X primary controls)																						8							
Secondary controls																													
None																					0								
Compensator override (for E, H, & R primary controls only)																						P							
Low torque limiter override (for E, H, & R primary controls only)																							J						
High torque limiter override (for E, H, & R primary controls only)																							K						
External drive																													
None																						-0							
rear blanking plate																							-M						
SAE-A (SAE 82-2) with SAE-A (SAE 16-4) coupling																							-A						
SAE-A (SAE 82-2) with SAE-B (SAE 22-4) coupling																							-G						
SAE-B (SAE 101-2 & SAE 101-4) with SAE-B (SAE 22-4) coupling																							-B						
SAE-B (SAE 101-2 & SAE 101-4) with SAE-BB (SAE 25-4) coupling																							-Q						
SAE-C (SAE 127-2 & SAE 127-4) with SAE-C (SAE 32-4) coupling																							-C						
SAE-C (SAE 127-2 & SAE 127-4) with SAE-CC (SAE 38-4) coupling																							-N						
SAE-D (SAE 152-2 & SAE 152-4) with SAE-D & SAE-E (SAE 44-4) coupling																							-D						
SAE-E (SAE 165-2 & SAE 165-4) with SAE-D & SAE-E (SAE 44-4) coupling (P12/200 and P16/260 only)																							-E						
ISO 180 B4HW Flange, K40N coupling																							-T						
ISO 180 B4HW Flange, K50N coupling																							-U						
ISO 180 B4HW Flange, DIN 40-18 coupling (P16/260 only)																							-L						
ISO 180 B4HW Flange, DIN 50-24 coupling (P16/260 only)																							-S						
ISO 224 B4HW Flange, K50N coupling (P12/200 and P16/260 only)																							-R						
ISO 250 B4HW Flange, K50N coupling (P16/260 only)																							-V						
ISO 200 B4HW Flange, K50N coupling (P12/200 and P16/260 only)																							-W						
ISO 160 B4HW Flange, K40N coupling																							-X						
ISO 125 B4HW Flange, K32N coupling																							-Y						
ISO 100 B4HW Flange, K25N coupling																							-Z						
External mounting																													
No external pump mounted																							0						
External pump mounted (requires special modification "-M2")(must be separately specified)																								1					
Special modification																													
None																							omit						
No paint																									-NP				
Other special modification (examples: bronze caged barrel bearing for low viscosity fluids, mechanical shaft seal, hydrostatic cam, tandem pumps, etc.)																												-M2	
Allowable controls																													
C10, C20, C30, C40, C50, C60, C70, C80, E10, E30, E40, E50, E1P, E3P, E4P, E5P, E1J, E3J, E4J, E5J, E1K, E3K, E4K, E5K																													
H10, H30, H40, H50, H1P, H3P, H4P, H5P, H1J, H3J, H4J, H5J, H1K, H3K, H4K, H5K, J10, J20, J30, J40, J50, J60, J70, J80																													
K10, K20, K30, K40, K50, K60, K70, K80, L10, L20, L30, L40, L50, L60, L70, L80, M10, M20, M30, M40, M50, M60, M70, M80																													
R10, R30, R40, R50, R1P, R3P, R4P, R5P, R1J, R3J, R4J, R5J, R1K, R3K, R4K, R5K, V10, V20, V30, V40, V50, V60, V70, V80																													
W10, W20, W30, W40, W50, W60, W70, W80, X10, X50, Y10, Y20, Y30, Y40, Y50, Y60, Y70, Y80, Z10, Z20, Z30, Z40, Z50, Z60, Z70, Z80																													

Denison Hydraulics Inc

**14249 Industrial Parkway
Marysville, OH 43040 USA**
Tel : 937-644-3915
Fax : 937-642-3738
E-mail:
denison@denisonhydraulics.com

Call toll-free
800-551-5956
*in North America or
 visit*
www.denisonhydraulics.com
*to locate a
 Denison representative
 nearest you.*

North America

Canada

Denison Hydraulics Canada Inc.
 2880 Brighton Road, Unit 1
 Oakville, ON L6H 5S3, Canada
 Tel : +1 (905) 829-5800
 Fax : +1 (905) 829-5805

Latin America

Mexico, Central America, South America, Caribbean countries

Denison Hydraulics Inc.
 7850 NW 146 Street
 Suite 512
 Miami Lakes, FL 33016, USA
 Tel : +1 (305) 362-2246
 Fax : +1 (305) 362-6220

Asia-Pacific

Australia

Denison Hydraulics PTY
 41-43 St Hilliers Road
 P.O.Box 192
 Auburn N.S.W. 2144, Australia
 Tel : +61 (2) 9646 5200
 Fax : +61 (2) 9643 1305

Hong Kong

Denison Hydraulics Ltd.
 Unit 6A, 33/F Cable TV Tower
 9 Hoi Shing Road, Tsuen Wan
 NT, Hong Kong
 Tel : +852 2498 8381
 Fax : +852 2499 1522

Japan

Denison Japan Inc.
 4-2-1 Tsujido-Shinmachi
 Fujisawa 251-0042, Japan
 Tel : +81 (466) 35-3050
 Fax : +81 (466) 35-2019

People Republic of China

Shanghai Denison Hydraulics
 Engineering Ltd.
 Room 8018, No. 601
 Zhang Yang Road,
 Pudong New Area
 Shanghai 200120, P.R. China
 Tel : +86 (21) 58205042 / 34
 Fax : +86 (21) 58205014

Singapore

Denison Hydraulics PTE LTD
 Blk 4012 Ang Mo Kio Ave 10,
 Unit #07-01D Techplace I
 Singapore 569628
 Tel : +65 268 7840
 Fax : +65 268 7847

Taiwan

Denison Hydraulics LTD
 6F-10, No. 79,
 Sec. 2 Roosevelt Rd,
 Taipei, Taiwan, ROC
 Tel : +886-2-23645101
 Fax : +886-2-23639025

Europe

Austria

Denison Hydraulics GmbH
 Zweigniederlassung Linz
 Haibachstraße 69
 4061 Pasching, Austria
 Tel : +43 (72 29) 48 87
 Fax : +43 (72 29) 6 30 92

Benelux

Denison Hydraulics Benelux B.V.
 Pascalstraat 100
 3316 GR Dordrecht, Holland
 Tel : +31 (78) 6543 070
 Fax : +31 (78) 6175 755

Denmark

Denison Hydraulics Denmark A/S
 Industriekrogen 2
 2635 Ishøj, Denmark
 Tel : +45 (4371) 15 00
 Fax : +45 (4371) 15 16

Finland

Denison Lokomec Oy
 Polunmäenkatu 22
 P.O. Box 116
 33721 Tampere, Finland
 Tel : + 358 (3) 357 5100
 Fax : + 358 (3) 357 5111

France

Denison Hydraulics S.A.
 14 route du bois blanc
 BP 539
 18105 Vierzon, France
 Tel : +33 (2) 48 53 01 20
 Fax : +33 (2) 48 75 02 91

Great Britain

Denison Hydraulics UK LTD
 Kenmore Road
 Wakefield 41, Industrial Park
 Wakefield, WF2 0XE
 West Yorkshire, England
 Tel : +44 (1924) 826 021
 Fax : +44 (1924) 826 146

Germany

Denison Hydraulics GmbH
 Auf dem Sand 14
 D 40721 Hilden, Germany
 Tel : +49 (0) 2103 / 940-3
 Fax : +49 (0) 2103 / 940-558

Italy

Denison Hydraulics Srl
 Via Le Europa 68
 20090 Cusago (MI), Italy
 Tel : +39 (02) 90330-1
 Fax : +39 (02) 90390694/5/6

Denison Calzoni S.p.A
 Via Caduti di Sabbiano15/17
 40011 Anzola dell'Emilia
 Bologna, Italy
 Tel : +39 (051) 6501611
 Fax : +39 (051) 736221

Spain

Denison Hydraulics S.A.
 Gomis 1
 08023 Barcelona, Spain
 Tel : +34 (93) 253 1990
 Fax : +34 (93) 211 6507

Sweden

Denison Hydraulics Svenska AB
 Sporregatan 13
 213 77 - Malmö, Sweden
 Tel : +46 (40) 600 13 00
 Fax : +46 (40) 600 13 50

Others

Other European, Middle East, African countries

Denison Hydraulics S.A.
 ATTN: Export Office
 14 route du bois blanc
 BP 538
 18105 Vierzon, France
 Tel : +33 (2) 48 53 01 20
 Fax : +33 (2) 48 53 01 46

For more information, please contact:

